



OPERATOR'S MANUAL

BPD290VF



**KEEP READ AND UNDERSTAND THE OPERATOR'S MANUAL
AND SAFETY INFORMATION BEFORE OPERATING THIS MACHINE!**

NOTE

The information contained in this handbook is intended as a guide to the operation of these machines and does not form part of any contract. The data it contains has been obtained from the machine manufacturer and from other sources. Whilst every effort has been made to ensure the accuracy of these transcriptions it would be impracticable to verify each and every item. Furthermore, development of the machine may mean that the equipment supplied may differ in detail from the descriptions herein. The responsibility therefore lies with the user to satisfy himself that the equipment or process described is suitable for the purpose intended.

LIMITED WARRANTY

We Make every effort to assure that its products meet high quality and durability standards and warrants to the original retail consumer/purchaser of our products that each product be free from defects in materials and workmanship as follow: **ONE YEAR LIMITED WARRANTY ON ALL PRODUCTS UNLESS SPECIFIED OTHERWISE.** This Warranty does not apply to defects due directly or indirectly to misuse, abuse, negligence or accidents, normal wear-and tear, repair or alterations outside our facilities, or to a lack of maintenance.

We shall in no event be liable for death, injuries to persons or property or for incidental, contingent, special, or consequential damages arising from the use of our products.

To take advantage of this warranty, the product or part must be returned to us for examination, postage prepaid. Proof of purchase date and an explanation of the complaint must accompany the merchandise. If our inspection discloses a defect, we will either repair or replace the product, or refund the purchase price if we cannot readily and quickly provide a repair or replacement, if you are willing to accept a refund. We will return repaired product or replacement at our expense, but if it is determined there is no defect, or that the defect resulted from causes not within the scope of our's warranty, then the user must bear the cost of storing and returning the product.

The manufacturers reserve the right to change specifications at any time as they continually strive to achieve better quality equipment.

Copyright. The copyright of this instruction book is the property of us and may not be reproduced or copied without prior consent of us.



WARNING!

Read and understand the entire instruction manual before attempting set-up or operation of this machine!

- 1. This machine is designed and intended for use by properly trained and experienced personnel only.** If you are not familiar with the proper safe use of lathes, do not use this machine until proper training and knowledge has been obtained.
- 2. Keep guards in place.** Safety guards must be kept in place and in working order.
- 3. Remove adjusting keys and wrenches.** Before turning on machine, check to see that any adjusting wrenches are removed from the tool.
- 4. Reduce the risk of unintentional starting.** Make sure switch is in the OFF position before plugging in the tool.
- 5. Do not force tool.** Always use a tool at the rate for which it was designed.
- 6. Use the right tool.** Do not force a tool or attachment to do a job for which it was not designed.
- 7. Maintain tools with care.** Keep tools sharp and clean for best and safest performance. Follow instructions for lubrication and changing accessories.
- 8. Always disconnect the machine from the power source before adjusting or servicing.**
- 9. Check for damaged parts.** Check for alignment of moving parts, breakage of parts, mounting, and any other condition that may affect the tools operation. A guard or any part that is damaged should be repaired or replaced.
- 10. Turn power off. Never leave a machine unattended.** Do not leave a machine until it comes to a complete stop.
- 11. Keep work area clean,** Cluttered areas and bench invite accidents.
- 12. Do not use in a dangerous environment.** Do not use power tools in damp or wet locations, or expose them to rain. Keep work area well lighted.
- 13. Keep children and visitors away.** All visitors should be kept a safe distance from the work area.
- 14. Make the workshop child proof.** Use padlocks, master switches, and remove starter keys.
- 15. Wear proper apparel.** Loose clothing, gloves, neckties, rings, bracelets, or other jewelry may get caught in moving parts. Non-slip footwear is recommended. Wear protective hair covering to contain long hair. Do not wear any type of glove.
- 16. Always use safety glasses.** Every day glasses only have impact resistant lenses; they are not safety glasses.
- 17. Do not overreach.** Keep proper footing and balance at all times.
- 18. Do not put hands near the cutter while the machine is operating.**
- 19. Do not perform any set-up work while machine is operating.**
- 20. Read and understand all warnings posted on the machine.**
- 21. This manual is intended to familiarize you with the technical aspects of this lathe.** It is not, nor was it intended to be a training manual.
- 22. Failure to comply with all of these warnings may result in serious injury.**
- 23. Some dust created** by power sanding, sawing, grinding, drilling and other construction activities contains chemicals known to cause cancer, birth defects or other reproductive harm. Some examples of these chemicals are lead from lead based paint; crystalline silica from bricks and cement and other masonry products.
- 24. Your risk from those exposures** varies, depending on how often you do this type of work. To reduce your exposure to these chemicals: work in a well ventilated area, and work with approved safety equipment, such as those dust masks that are specifically designed to filter our microscopic particles.

SPECIFICATIONS:

Capacities:		BPD290VF
Swing Over Bed		11 in
Swing Over Cross Slide		6.49 in
Distance Between Centers		27.5 in
Width of Bed		7.086 in
Headstock:		
Hole Through Spindle		1.496 in
Taper of Spindle Bore		MT5
Number of Spindle Speeds		Variable
Range of Spindle Speeds		50-2000RPM
Feeding and Threading:		
Number of Imperial Threads		21
Range of Imperial Threads		8~56 T.P.I.
Range of Cross Feed		0.0015~0.0056 in/r
Range of Longitudinal Feeds		0.0025~0.012 in/r
Compound and Carriage:		
Maximum Compound Slide Travel		3.1 in
Maximum Cross Slide Travel		5.51 in
Maximum Cross Slide Travel		22 in
Tailstock:		
Tailstock Spindle Travel		3.1 in
Taper in Tailstock Spindle		MT3
Miscellaneous:		
Motor		1.0KW
Dimension:		
Length		55.1 in
Width		28.7 in
Height		38.58 in
Weight		370KGS

TABLE OF CONTENTS

LIMITED WARRANTY.....	1
SAFETY WARNINGS	2
SPECIFICATIONS	3
TABLE OF CONTENTS	4
CONTENTS OF SHIPPING CONTAINER	5
UNCRATING AND CLEAN-UP	6
FOUNDATION DRAWING	6
GENERAL DESCRIPTION.....	7
CONTROLS.....	9
OPERATION	11
LATHE ACCESSORIES.....	16
ADJUSTMENT.	18
LUBRICATION	19
ELECTRICAL CONNECTION	20
MAINTENANCE	21
TRUBLE SOLUTION	22



WARNING!

**Read and understand the entire contents of this Manual before attempting set-up or operation!
Failure to comply may cause serious injure!**

CONTENTS OF SHIPPING CONTAINER

- 1 BPD290VF Combination
- 2 Test Flow Chat
- 1 Toolbox & Tools

TOOLBOX CONTENTS (Fig. 01)

- 1 Dead Center MT5
- 1 Dead Center MT3
- 3 External Jaw
- 1 Oil Gun
- 1 Spanner for Spindle Adjustment
- 1 Cross Screwdriver
- 1 Flat Screwdriver
- 1 Key for 3-Jaw Chuck
- 1 Tool Post Square Wrench
- 5 Hex Socket Wrench
- 3 Double End Head Wrench
- 1 One Sets of Change Gears



Fig. 01

UNCRATING AND CLEAN-UP

1. Finish removing the wooden crate from around the lathe
2. Check all the accessories of the machine tool according to the packing list.
3. Unbolt the lathe from the shipping crate bottom.
4. Choose a location for the lathe that is dry, has good lighting and has enough room to be able to service the lathe on all four sides.
5. With adequate lifting equipment, slowly raise the lathe off the shipping crate bottom. **Do not lift by spindle.** Make sure lathe is balanced before moving to sturdy bench or stand.
6. To avoid twisting the bed, the lathe's location must be absolutely flat and level. Bolt the lathe to the stand (if used). If using a bench, through bolt for best performance.
7. Clean all rust protected surfaces using a mild commercial solvent, kerosene or diesel fuel. Do not use paint thinner, gasoline or lacquer thinner. These will damage painted surfaces. Cover all cleaned surfaces with a light film of 20W machine oil.
8. Remove the end gear cover. Clean all components of the end gear assembly and coat all gears with a heavy, non-slinging grease.

FOUNDATION DRAWING

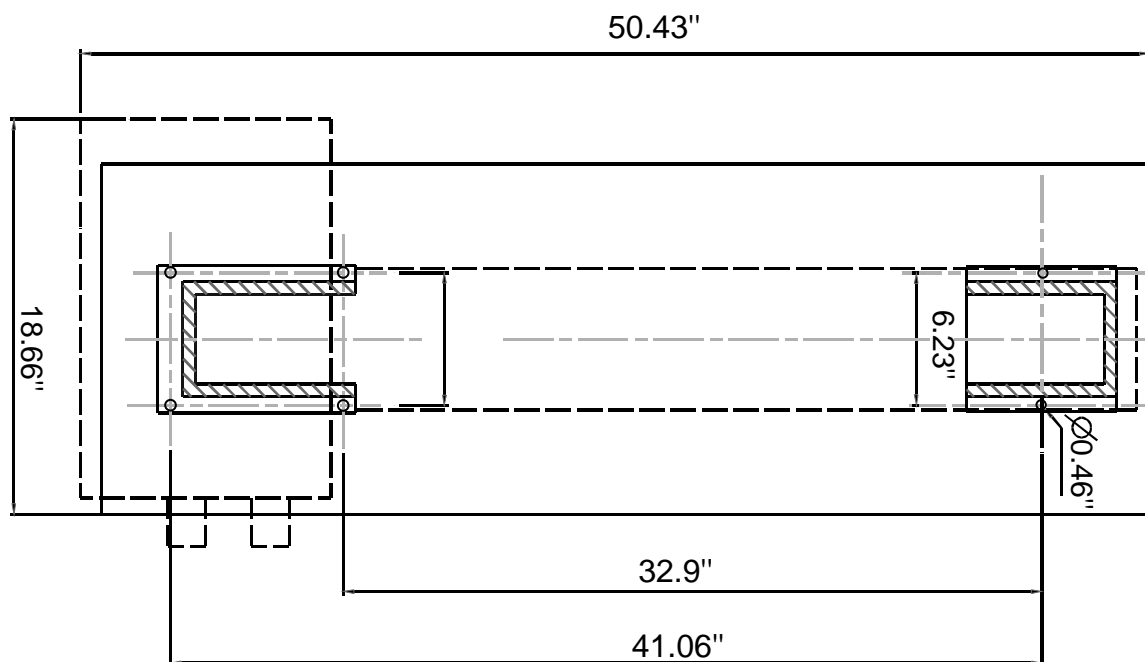

Fig. 02

GENERAL DESCRIPTION

Lathe Bed (Fig. 03)

The lathe bed is made of high-grade iron. By combining high cheeks with strong cross ribs, a bed of low vibration and rigidity is produced. It integrates the headstock and drive unit, for attaching the carriage and leadscrew. The two precision-ground V – sideways, re-enforced by heat hardening and grinding, are the accurate guide for the carriage and tailstock. The main motor is mounted to the rear of the left side of the bed.

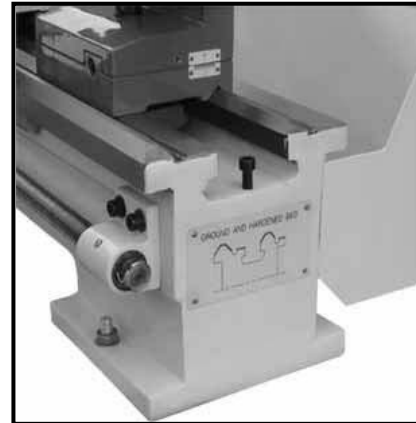

Fig. 03

Headstock (Fig. 04)

The headstock is cast from high grade, low vibration cast iron. It is bolted to the bed with four screws. The headstock houses the main spindle with two precision taper roller bearings and the drive unit.

The main spindle transmits the torque during the turning process. It also holds the workpieces and clamping devices. (e.g. 3-jaw chuck).



Fig. 04

Gear Box (Fig. 05)

The gear box is made from high quality cast iron and is mounted on the left side of the machine bed. It is used to select the feeds for straight turning as well as for thread cutting. In order to achieve certain thread pitches, it is necessary to replace the change gears.

The torque of the work spindle is transmitted to the feed gear and thus to the leadscrew.



Fig. 05

Carriage (Fig. 06)

The carriage is made from high quality cast iron. The slide parts are smoothly ground. They fit the V on the bed without play. The lower sliding parts can be easily and simply adjusted. The cross slide is mounted on the carriage and moves on a dove tailed slide. Play in the cross slide may be adjusted with the gibs.

Move the cross slide with its conveniently positioned handwheel. There is a graduated collar on the handwheel.

The top slide, mounted on the cross slide, can be rotated 360°. The top slide and the cross slide travel in dove tailed slides and have gibs, adjustable nuts, and graduated collars.

A four way tool post is fitted on the top slide and allows four tools to be clamped. Loosen the center clamp handle to rotate any of the four tools into position.

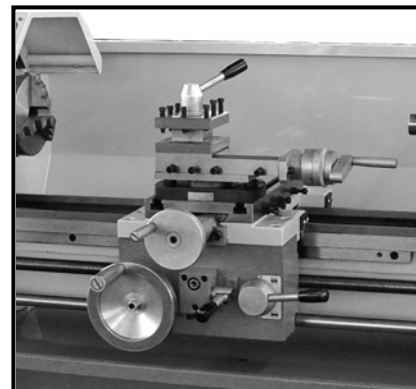

Fig.06

Apron (Fig. 07)

The apron is mounted on the bed. It houses the half nut with an engaging lever for activating the automatic feed. The half nut gibs can be adjusted from the outside.

A rack, mounted on the bed, and a pinion operated by handwheel on the carriage allow for quick travel of the apron.

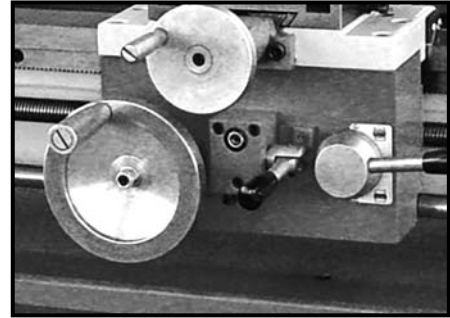

Fig.07

Leadscrew (Fig. 08)

The leadscrew is mounted on the front of the machine bed. It is connected to the gear box at the left for automatic feed and is supported by bearing on both ends. The two groove nuts (A, Fig. 10) on the right end are designed to take up play on the leadscrew.

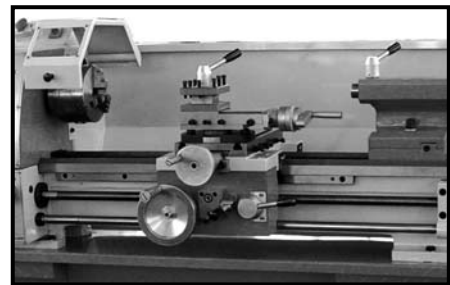

Fig. 08

Tailstock (Fig. 09)

The tailstock slides on a V way and can be clamped at any location. The tailstock has a heavy-duty spindle with a Morse taper No. 2 socket and a graduated scale. The spindle can be clamped at any location with a clamping lever. The spindle is moved with a handwheel at the end of the tailstock.

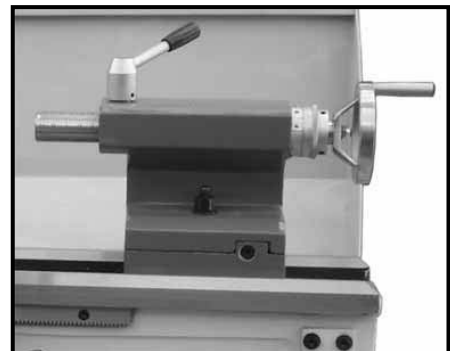

Fig. 09

NOTE:

Fit the securing screw (B, Fig. 10) at the end of the lathe bed in order to prevent the tailstock from falling off the lathe bed.

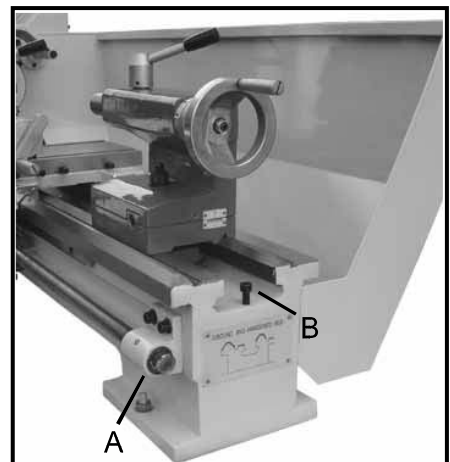

Fig. 10

CONTROLS

1. Change-over Switch (A, Fig. 11)

After the machine is switched on, turn the switch to “F” position for counter-clockwise spindle rotation (forward). Turn the switch to “R” position for clockwise spindle rotation (reverse). “0” position is OFF and the spindle remains idle.

2. Emergency Button ON/OFF Switch (B, Fig. 11)

The machine is switched on and off with ON/OFF button. Depress to stop all machine functions. To restart, lift the cover and press ON button.

3. Variable Speed Control Switch (C, Fig. 11)

Turn the switch clockwise to increase the spindle speed. Turn the switch counter-clockwise to decrease the spindle speed. The possible speed range is dependent from the position of the drive belt.

4. Feed Direction Selector (D, Fig. 12)

Select carriage travel direction when the chuck is rotating in the forward direction or counter-clockwise as viewed from the front of the chuck.

5. Feed Rate Selector (E, Fig. 12)

Set the desired feed or thread rates.

6. Feed/Thread Selector (F, Fig. 12)

Select the handle for shift left to thread.
Select the handle for shift right to feed.

7. Compound Rest Lock

Turn two hex nuts (G, Fig. 13) clockwise to lock and counter-clockwise to unlock.

8. Compound Slide Lock

Turn hex socket cap screws (H, Fig. 13) clockwise, and tighten to lock. Turn counter-clockwise to loosen.

9. Cross Slide Lock

Turn hex socket cap screw (I, Fig. 13) clockwise and tighten to lock. Turn counter-clockwise and loosen to unlock.

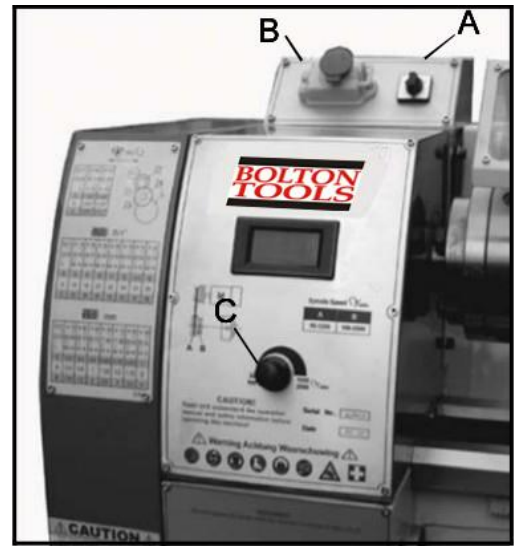

Fig. 11



Fig. 12

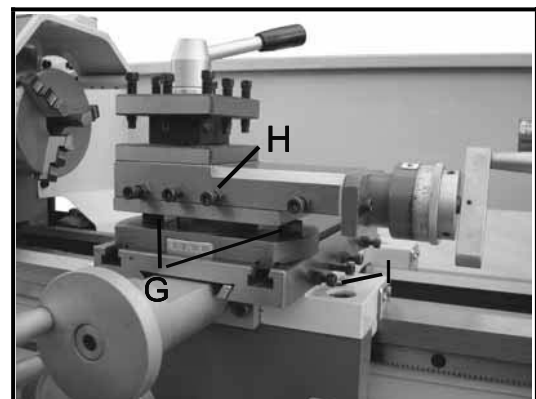

Fig. 13

9. Carriage Lock

Turn hex socket cap screw (A, Fig.14) clockwise and tighten to lock. Turn counter-clockwise and loosen to unlock.

Caution: carriage lock screw must be unlocked before engaging automatic feeds or damage to lathe may occur.

10. Longitudinal Traverse (B, Fig. 15)

Rotate hand wheel clockwise to move the apron assembly toward the tailstock (right). Rotate the hand wheel counter-clockwise to move the apron assembly toward the headstock (left).

11. Cross Traverse Handwheel (C, Fig. 15)

Clockwise rotation moves the cross slide toward the rear of the machine.

12. Half Nut Engage Lever (D, Fig. 15)

Move the lever down to engage. Move the lever up to disengage.

13. Compound Rest Traverse Lever (E, Fig. 15)

Rotate clockwise or counter-clockwise to move or position.

14. Tool Post Clamping Lever (F, Fig. 15)

Rotate counter-clockwise to loosen and clockwise to tighten. Rotate the tool post when the lever is unlocked.

15. Feed axis Selector (G, Fig. 15)

Push lever (G, Fig.15) to the left and down to engage cross feed Pull lever to the right and up to engage longitudinal feed.

16. Tailstock Clamping Screw (H, Fig. 16)

Turn hex nut clockwise to lock and counter-clockwise to unlock.

17. Tailstock Quill Clamping Lever (I, Fig. 16)

Rotate the lever clockwise to lock the spindle and counter-clockwise to unlock.

18. Tailstock Quill Traverse Handwheel (J, Fig. 16)

Rotate clockwise to advance the quill. Rotate counter-clockwise to retract the quill

19. Tailstock Off-set Adjustment (K, Fig. 16)

Three sets screws located on the tailstock base are used to off-set the tailstock for cutting tapers. Loosen lock screw on tailstock end. Loosen one side set screw while tightening the other until the amount of off-set is indicated on scale. Tighten lock screw.

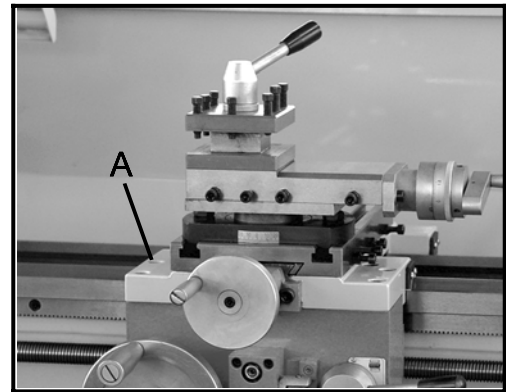

Fig. 14

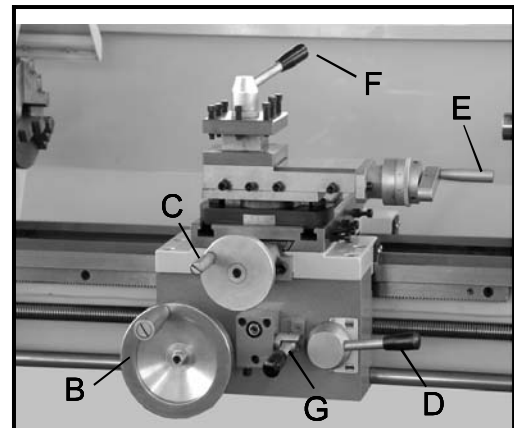

Fig. 15

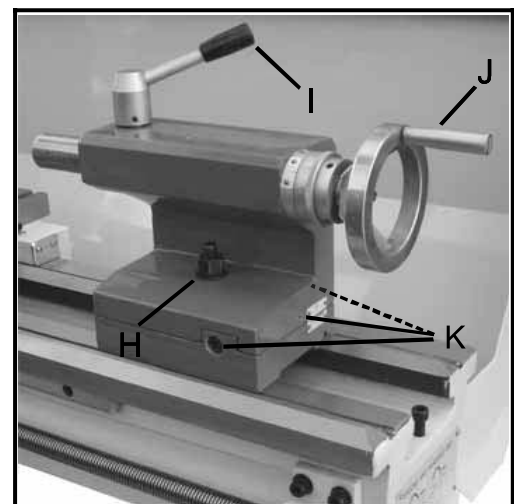

Fig. 16

OPERATION

Replacement of Chuck

The head spindle holding fixture is cylindrical. Loose three set screws and nuts (A, Fig.17, only two are shown) on the lathe chuck flange to remove the chuck. Position the new chuck and fix it using the same set screws and nuts.

Tool Set-Up

Clamp the turning tool into the toolholder.

The tool must be clamped firmly. When turning, the tool has a tendency to bend under the cutting force generated during the chip formation. For best results, tool overhang should be kept to a minimum of 3/8" or less.

The cutting angle is correct when the cutting edge is in line with the center axis of the work piece. The correct height of the tool can be achieved by comparing the tool point with the point of the center mounted in the tailstock. If necessary, use steel spacer shims under the tool to get the required height. (Fig. 18)

Change H/L Speed

1. Unscrew the two fastening screws (B, Fig.19) and remove the protective cover.
2. To selection A or B according to your requirement , A is low speed, B is high speed. (Fig. 20)

Caution: we suggestion our customers to select low speed position to work, it is could provides stronger torque for working!

Belt Adjusted

Loosen the four nuts and screws (C, Fig. 20) to remove the plate of mounting motor and position!

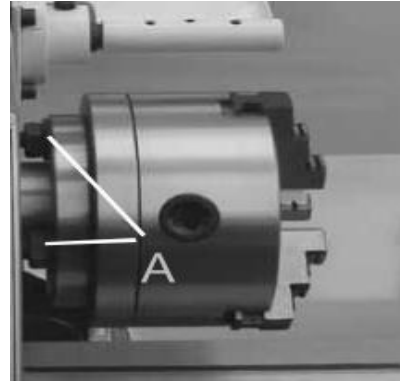

Fig. 17



Fig. 18



Fig. 19

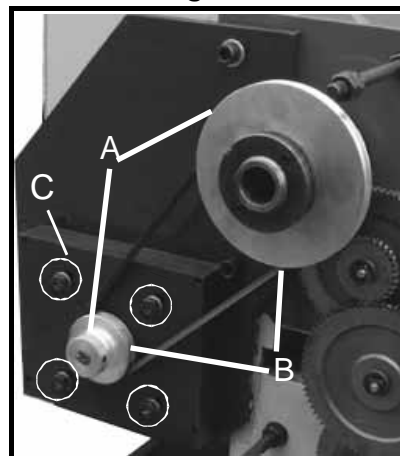

Fig. 20

Manual Turning

Apron travel, cross travel, and top slide handwheel can be operated for longitudinal or cross feeding. (Fig.21)

Longitudinal Turning with Auto-Feed

1. Set the selector knob (A, Fig.22) to select the feed direction and feed speed.
2. Use the table (B, Fig.22) on the lathe for selecting the feed speed or the thread pitch. Adjust the change gear if the required feed or thread pitch cannot be obtained with the installed gear set.

Change Gears Replacement

1. Disconnect the machine from the power source.
2. Unscrew the two fastening screws and remove the protective cover.
3. Loosen the locking screw (C, Fig.23) on the quadrant.
4. Swing the quadrant (D, Fig.23) to the right.
5. Unscrew the bolt (E, Fig.23) from the leadscrew or the square bolts (F, Fig.23) from the quadrant bolts in order to remove the change gears from the front.
6. Install the gear couples according to the thread and feed table and screw the gearwheels onto the quadrant again.
7. Swing the quadrant to the left until the gearwheels have engaged again.
8. Readjust gear backlash by inserting a normal sheet of paper as an adjusting or distance aid between the gearwheels.
9. Immobilize the quadrant with the locking screw.
10. Install the protective cover of the headstock and reconnect the machine to the power supply.

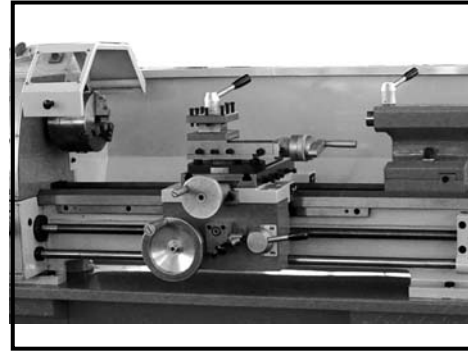

Fig. 21



Fig. 22

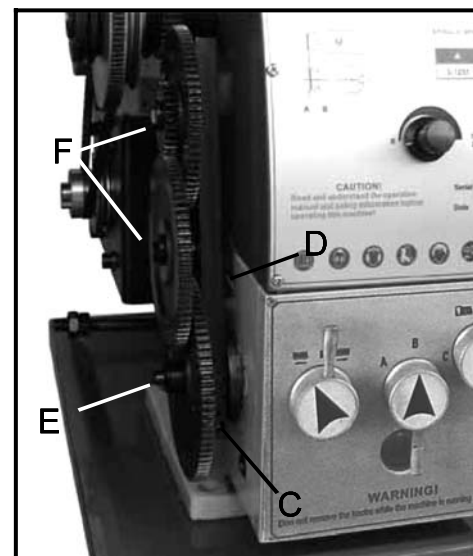

Fig. 23

Straight Turning (Fig. 25)

In the straight turning operation, the tool feeds parallel to the axis of rotation of the workpiece. The feed can be either manual by turning the handwheel on the lathe saddle or the top slide, or by activating the automatic feed. The crossfeed for the depth of cut is achieved using the cross slide.

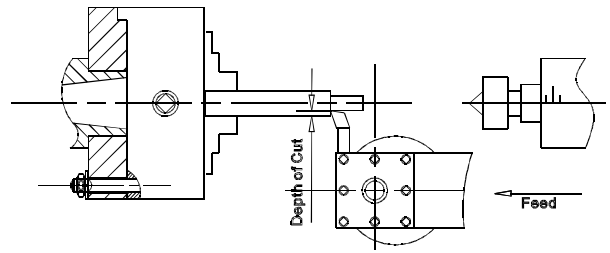

Fig. 25

Facing and Recesses (Fig. 26)

In the facing operation, the tool feeds perpendicular to the axis of rotation of the workpiece. The feed is made manually with the cross slide handwheel. The crossfeed for cut depth is made with the top slide or lathe saddle.

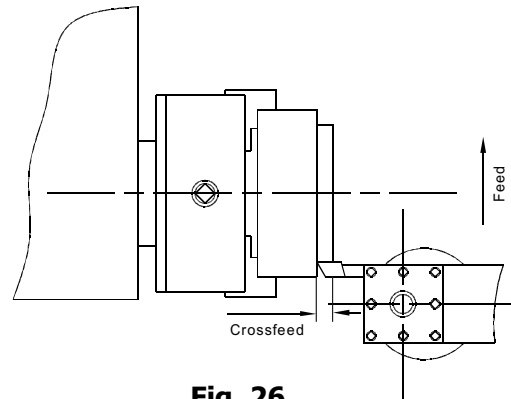
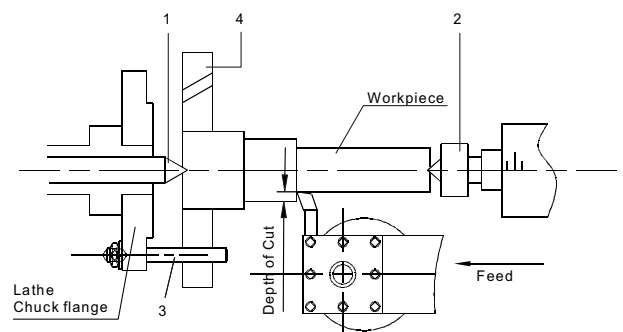

Fig. 26

Turning Between Centers (Fig. 27)

For turning between centers, it is necessary to remove the chuck from the spindle. Fit the M.T.3 center into the spindle nose and the M.T. 2 center into the tailstock. Mount the workpiece fitted with the driver dog between the centers. The driver is driven by a catch or face plate.



- 1.Fixed Centre 60°
- 2.Living Centre 60°
- 3.Dog Drive Pin
- 4.Dog Plate

Fig. 27

Note: Always use a small amount of grease on the tailstock center to prevent center tip from overheating.

Taper Turning Using Tailstock Off-Set

Work to a side angle of 5 can be turned by off-setting the tailstock. The angle depends on the length of the workpiece.

To off-set the tailstock, loosen locking screw (A, Fig.28) Unscrew the set screw (B, Fig.28) on right end of the tailstock. Loosen the front adjusting screw(C, Fig.28) and take up the same amount by tightening the rear adjusting screw (D, Fig.28) until the desired taper has been reached. The desired cross-adjustment can be read off the scale. (E, Fig.28). First retighten the set screw (B, Fig.28) and then the two (front and rear) adjusting screw to lock the tailstock in position. Retighten the locking screw (A, Fig.28) of the tailstock. The workpiece must be held between to centers and driven by a face plate and driver dog.

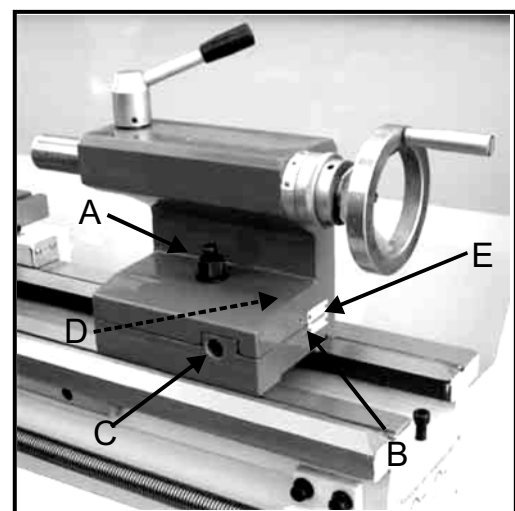

Fig. 28

After taper turning, the tailstock should be returned to its original position according to the zero position on the scale of tailstock. (E, Fig.28)

Taper Turning by Setting the Top Slide

By angling the top slide, tapers may be turned manually with the top slide. (Fig. 29)

Rotate the top slide to the required angle. A graduated scale permits accurate adjustment of the top slide. The crossfeed is performed with the cross slide. This method can only be used for short tapers.

Thread Cutting

Set the machine up to the desired thread pitch (according to the threading chart, Fig.24). Start the machine and engage the half nut. When the tool reaches the part, it will cut the initial threading pass. When the tool reaches the end of the cut, stop the machine by turning the motor off and at the same time back the tool out of the part so that it clears the thread. Do not disengage the half nut lever. Reverse the motor direction to allow the cutting tool to traverse back to the starting point. Repeat these steps until you have obtained the desired results.

NOTES

Example: Male Thread

- The workpiece diameter must have been turned to the diameter of the desired thread.
- The workpiece requires a chamfer at the beginning of the thread and an undercut at the thread runout.
- The speed must be as low as possible.
- The change gears must have been installed according to the required pitch.
- The thread cutting tool must be exactly the same shape as the thread, must be absolutely rectangular and clamped so that it coincides exactly with the turning center.
- The thread is produced in various cutting steps so that the cutting tool has to be turned out of the thread completely (with the cross slide) at the end of each cutting step.
- The tool is withdrawn with the leadscrew nut engaged by inverting the change-over switch.
- Stop the machine and feed the thread cutting tool in low cut depths using the cross slide.
- Before each passage, place the top slide approximately 0.0078" to 0.011" to the left and right alternately in order to cut the thread free. This way, the thread cutting tools cuts only on one thread flank with each passage. Keep cutting the thread free until you have almost reached the full depth of thread.

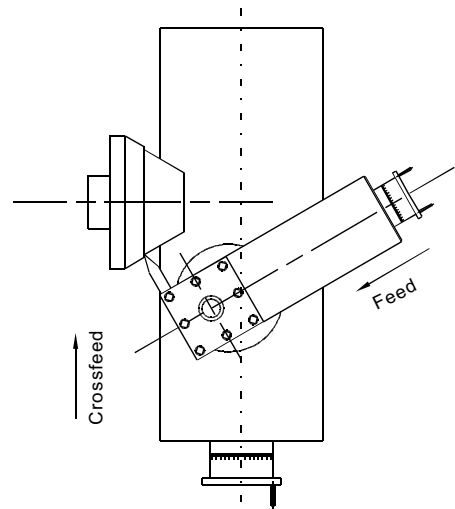

Fig. 29

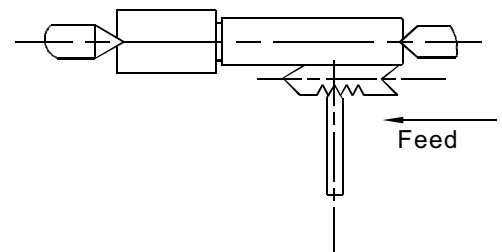

Fig. 30

LATHE ACCESSORIES

Three Jaw Universal Lathe Chuck

Using this universal chuck, round, triangular, square, hexagonal octagonal, and twelve-cornered stock may be clamped. (Fig.31)

Note: new lathes have very tight fitting jaws. This is necessary to ensure accurate clamping and long service life. With repeated opening and closing, the jaw adjust automatically and their operation becomes progressively smoother.

Note:

For the original 3-jaw chuck that mounted on the lathe, the factory has mounted the chuck in the best way to guarantee the holding accuracy with two "0" mark (A, Fig.31) showed on the chuck and chuck flange.

There are two types of jaws: Internal and external jaws. Please note that the number of jaws fit with the number inside the chuck's groove. Do not mix them together. When you are going to mount them, please mount them in ascending order 1-2-3, when you are going to take them out, be sure to take them out in descending order 3-2-1, one by one. After you finished this procedure, rotate the jaws to the smallest diameter and check that the three jaws are well fitted.

Four Jaw Independent Lathe Chuck

This special chuck has four independently adjustable chuck jaws. These permit the holding of asymmetrical pieces and enable the accurate set-up of cylindrical pieces. (Fig.32)

Drill Chuck (Optional)

Use the drill chuck to hold centering drills and twist drills in the tailstock. (A, Fig.33)

Morse Taper Arbor (Optional)

An arbor is necessary for mounting the drill chuck in the tailstock. It has a No. 2 Morse taper. (B, Fig.33)

Live Center (Optional)

The live center is mounted in ball bearings. Its use is highly recommended for turning at speeds in excess of 600 RPM. (Fig. 34)

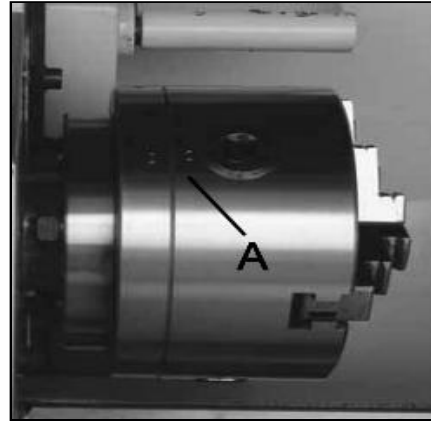

Fig. 31

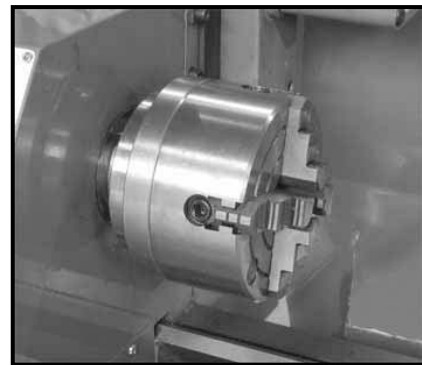

Fig. 32

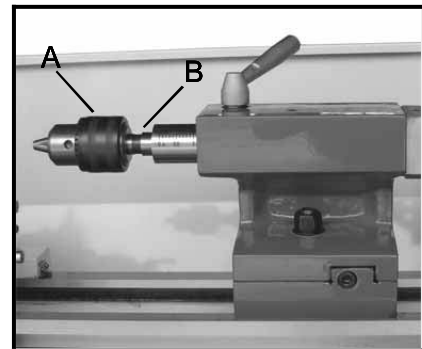

Fig. 33

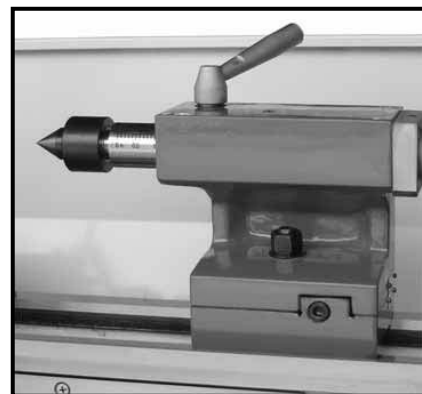

Fig. 34

Steady Rest

The steady rest serves as a support for shafts on the free tailstock end. For many operations the tailstock can not be used as it obstructs the turning tool or drilling tool, and therefore, must be removed from the machine. The steady rest, which function as an end support, ensures chatter-free operation. The steady rest is mounted on the bedways and is secured from below with a locking plate. The sliding fingers require continuous lubrication at the contact points to prevent premature wear. (Fig.35)

Setting the Steady Rest

1. Loosen three hex nuts. (A, Fig.36)
2. Loosen knurled screw (B, Fig.36) and open the sliding fingers. (C, Fig.36) until the steady rest can be moved with its finger around the workpiece. Secure the steady rest in position.
3. Tighten knurled screws so that fingers are snug but not tight against the workpiece. Tighten three nuts (A, Fig.36). Lubricate the sliding points with machine oil.
4. When, after prolonged operation, the jaw show wear, the tips of the fingers may be filed or remilled.

Follow Rest

The follow rest is mounted on the saddle and follow the movement of the turning tool. Only two sliding fingers are required. The place of the third finger is taken by the turning tool. The follow rest is used for turning operations on long, slender workpieces. It prevents flexing of the workpiece under pressure from the turning tool. (Fig.37)

Set the fingers snug to the workpiece but not overly tight. Lubricate the fingers during operation to prevent premature wear.

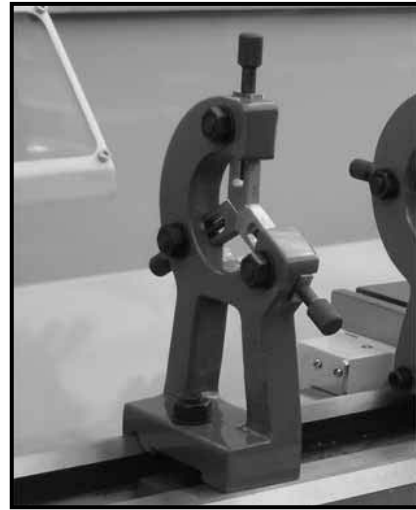

Fig. 35

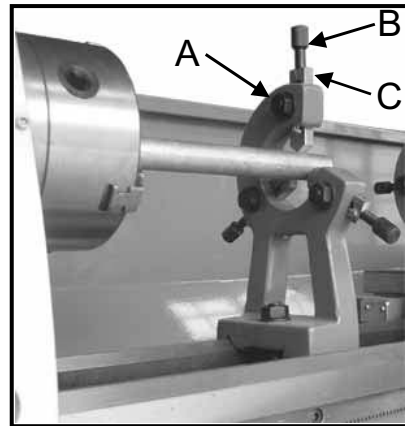

Fig. 36



Fig. 37

ADJUSTMENT

After a period time, wear in some of the moving components may need to be adjust

Main Spindle Bearings

The main spindle bearings are adjusted at the factory. If end play becomes evident after considerable use, the bearings may be adjusted.

Loosen two hex socket cap screws (A, Fig.38) in the slotted nut (B, Fig.38) on the back of the spindle. Tighten slotted nut until all end play is taken up. The spindle should still revolve freely. Tighten two hex socket cap screws (A, Fig.38).

Caution: excessive tightening or preloading will damage the bearings.

Adjustment of Cross Slide

The cross slide is fitted with a gib strip(C, Fig.39) and can be adjusted with screws (D, Fig.39) fitted with lock nuts. (E, Fig.39) Loosen the lock nuts and tighten the set screws until slide moves freely without play. Tighten lock nuts to retain adjustment.

Adjustment of Top Slide

The top slide is fitted with a gib strip(F, Fig.40) and can be adjusted with screws (G, Fig. 40) fitted with lock nuts. (H, Fig. 40) Loosen the lock nuts and tighten the set screws until slide moves freely without play. Tighten lock nuts to retain adjustment.

Adjustment of Half Nut Guide

Loosen the nut (I, Fig.41) on the right side bottom of the apron and adjust the control screws (J, Fig.41) until both half nuts move freely without play. Tighten the nut.

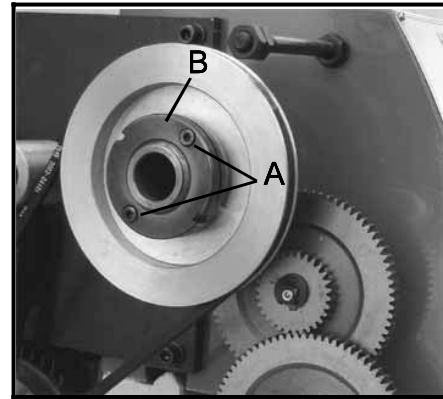

Fig. 38

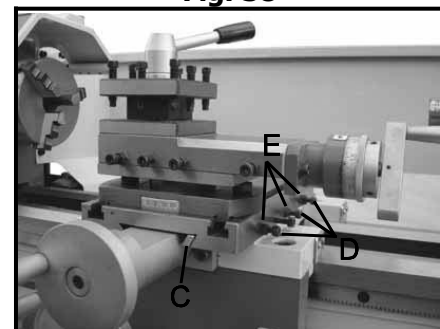

Fig. 39

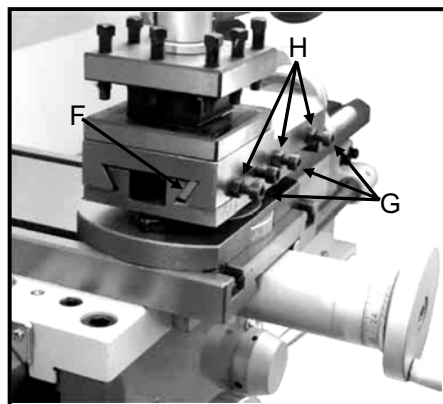

Fig. 40

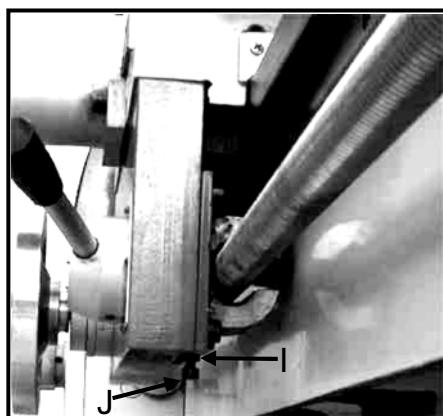

Fig. 41

LUBRICATION

CAUTION!

**Lathe must be serviced at all lubrication points and all reservoirs filled to operating level before the lathe is placed into service!
Failure to comply may cause serious damage!**

NOTES:

Lubricate all slideways lightly before every use. Lubricate the change gears and the leadscrew slightly with a lithium-based grease.

1. Gearbox

Oil Must be up to indicator mark in oil sight glass(A, Fig.42). Top off with Mobilgear 627 or equivalent. Fill by pulling plug (B, Fig. 42). To drain, remove drain plug on the right side of headstock(C, Fig.43). Drain oil completely and refill after the first three months of operation. Then, change oil in the headstock annually.

2. Change Gear

Lubricate two oil ports (D, Fig.43) on the gear shafts with 20W machine oil once daily.

3. Carriage

Lubricate Four oil ports (E, Fig. 44) with 20W machine oil once daily.

4. Cross Slide

Lubricate two oil ports (F, Fig. 44) with 20W machine oil once daily.

5. Apron

Lubricate two oil ports (G, Fig. 45) with 20W machine oil once daily.

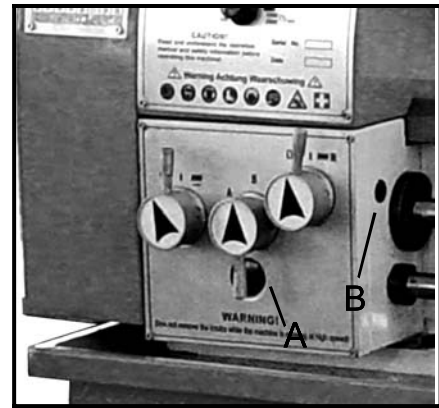

Fig. 42

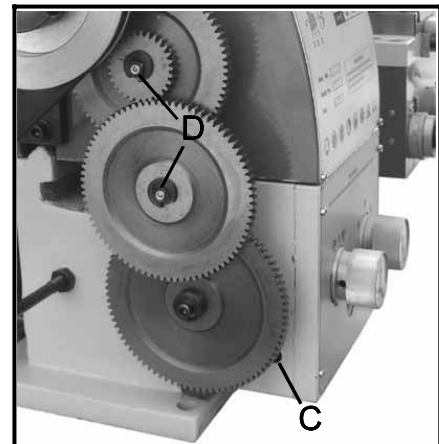

Fig. 43

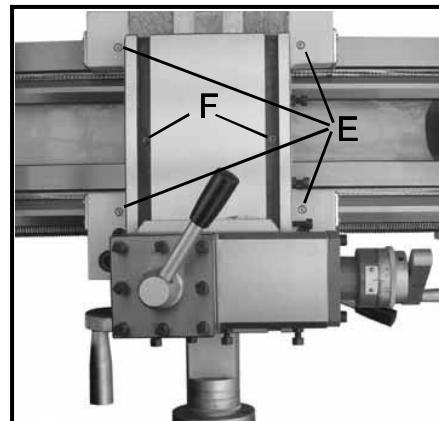

Fig. 44

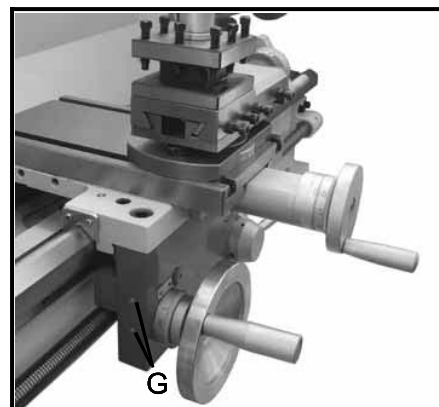

Fig. 45

6. Leadscrew

Lubricate the oil port (A, Fig. 46) with 20W machine oil once daily.

7. Tailstock

Lubricate two oil ports (B, Fig. 46) with 20W machine oil once daily.

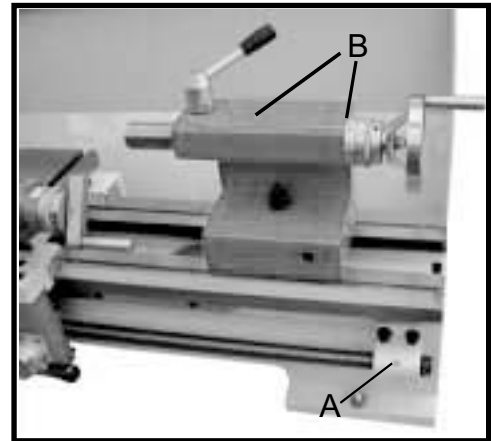

Fig. 46

ELECTRICAL CONNECTIONS

WARNING!

Connection of the lathe and all other electrical work may only be carried out by an authorized electrician!

Failure to comply may cause serious injury and damage to the machinery and property!

The BPD290VF Variable Speed Lathe is rated at 1KW, 110V only. Confirm power available at the lathe's location is the same rating as the lathe. Using the wiring diagram (Fig.47) for connecting the lathe to the mains supply.

Make sure the lathe is properly grounded.

The following is wiring diagram of the lathe: (Fig.47)

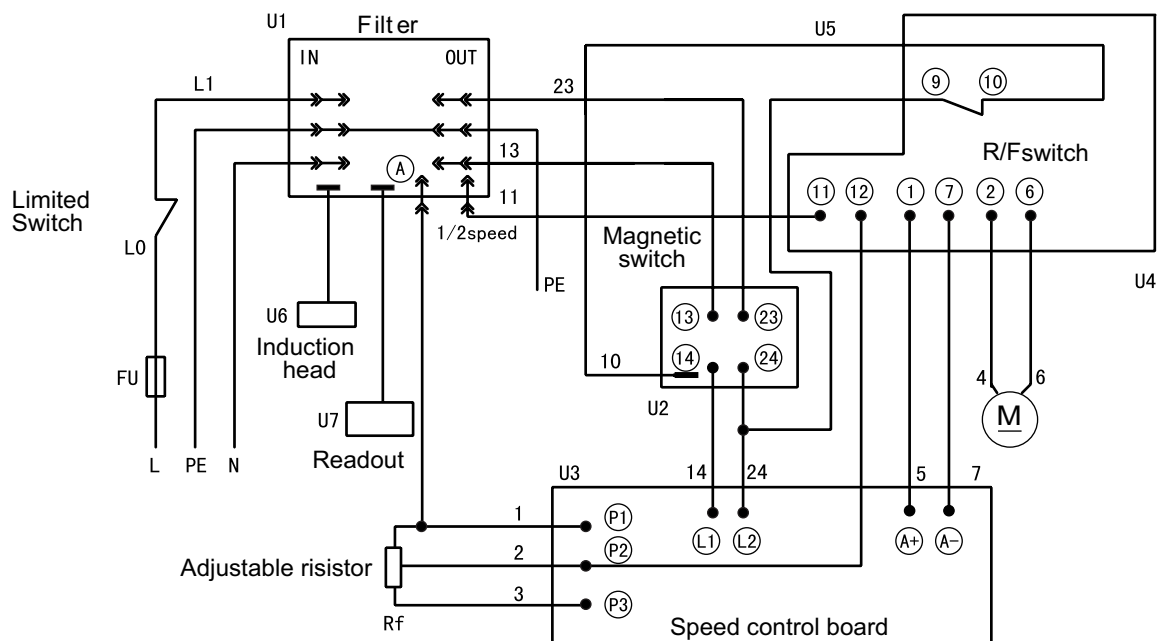

Fig.47

MAINTENANCE

Keep the maintenance of the machine tool during the operation to guarantee the accuracy and service life of the machine tool.

1. In order to retain the machine's precision and functionality, it is essential to treat it with care, keep it clean and grease and lubricate it regularly. Only through good care, you can be sure that the working quality of the machine will remain constant.

NOTES:

Disconnect the machine plug from the mains supply whenever you carry out cleaning, maintenance or repair work!

Oil, grease and cleaning agents are pollutants and must not be disposed of through the drains or in normal refuse. Dispose of those agents in accordance with current legal requirements on the environment. Cleaning rags impregnated with oil, grease and cleaning agents are easily inflammable. Collect cleaning rags or cleaning wool in a suitable closed vessel and dispose of them in an environmentally sound way – do not put them with normal refuse!

2. Lubrication all slideways lightly before every use. The change gears and the leadscrew must also be lightly lubricated with lithium base grease.
3. During the operation, the chips which falls onto the sliding surface should be cleaned timely, and the inspection should be often made to prevent chips falling into the position between the machine tool saddle and lathe bed guide way. Asphalt felt should be cleaned at certain time.

NOTES:

Do not remove the chips with your bare hands. There is a risk of cuts due to sharp-edged chips. Never use flammable solvents or cleaning agents or agents that generate noxious fumes! Protect electrical components such as motors, switches, switch boxes, etc., against humidity when cleaning.

4. After the operation every day, eliminate all the chips and clean different part of the machine tool and apply machine tool oil to prevent rusting.
5. In order to maintain the machining accuracy, take care of the center, the surface of the machine tool for the chuck and the guide way and avoid mechanical damage and the wear due to improper guide.
6. If the damage is found, the maintenance should be done immediately.

NOTES:

Repair work may only be carried out by qualified personnel with the corresponding mechanical and electrical knowledge.

TROUBLESHOOTING

Problem	Possible Reason	Elimination
Surface of workpiece too rough	Tool blunt Tool springs Feed too high Radius at the tool tip too small	Resharpen tool Clamp tool with less overhang Reduce feed Increase radius
Workpiece becomes coned	Centers are not aligned (tailstock has offset) Top slide not aligned well (cutting with the top slide)	Adjust tailstock to the center Align top slide well
Lathe is chattering	Feed too high Slack in main bearing	Reduce feed Adjust the main bearing
Center runs hot	Workpiece has expanded	Loosen tailstock center
Tool has a short edge life	Cutting speed too high Crossfeed too high Insufficient cooling	Reduce cutting speed Lower crossfeed(finishing allowance should not exceed 0.5mm) More coolant
Flank wear too high	Clearance angle too small Tool tip not adjusted to center high	Increase clearance angle Correct height adjustment of the tool
Cutting edge breaks off	Wedge angle too small (heat build-up) Grinding crack due to wrong cooling Excessive slack in the spindle bearing Arrangement (vibrations)	Increase wedge angle Cool uniformly Adjust the slack in the spindle bearing arrangement
Cut thread is wrong	Tool is clamped incorrectly or has been started grinding the wrong way Wrong pitch Wrong diameter	Adjust too to the center Grind angle correctly Adjust the right pitch Turn the workpiece to the correct diameter
Spindle does not activate	Emergency stop switch activated	Unlock emergency stop switch

BOLTON TOOLS

PARTS LIST FOR BPD290VF



Keep Read and Understand the Operation Manual and Safety Information
Before Operated!

BPD290VF VARIABLE SPEED LATHE

MAIN TECHNICAL SPECIFICATION

SPECIFICATION:

Drilling Capacity	0.787"
End Mill Capacity	0.63"
Face Mill Capacity	2.48"
Spindle Taper	MT2
Spindle Stroke	1.968"
Head Tilt	±90°
Number of Spindle Speeds	Variable
Ranger of Spindle Speeds	50~2250 RPM
Working Surface of Table	10.6"*5.9"
Number of T-Slots	2
T-Slot Size	0.39"
Motor	600W ,110V

The specifications in this manual are given as general information and are not binding. We reserves the right to effect, at any time and without prior notice, changes or alterations to parts, fitting and accessory equipment deemed necessary for any reason whatsoever.

MILL HEAD OPERATION

Head Elevating handwheel (A, Fig.48),

Located on the right of column. The head can be adjusted up or down to suit height requirements for different workpieces. Turn it clockwise to up head on the column and counter-clockwise to down. **When the head is at the desired height, lock in place with the locks.**

Caution: Have to loosen the locks for the slideways before above operation!

Mill Head locks (B, Fig.49)

Located on the right of column. Turn clockwise to lock the mill head.

Quill Lock Lever (C, Fig. 49)

Located on the left of the mill head. The height of the spindle can be locked with the quill lock lever. Set the desired height with the quill lever and turn the lever down. Turn clockwise to lock the quill, reverse to loosen.

Caution: For best results. All milling operations should be done with the quill/spindle as close to the head assembly as possible. Lock spindle, table and mill head in place before starting milling operations!

Down feed Handles: (D, Fig. 50):

Located on the right side of the head casting. Counter-clockwise movement advances the quill toward the table. Return spring retracts the handles. **The knob (E, Fig. 50) must be loose before the operating the handles.** The graduated dials (F, Fig. 03) on the handle base can be indexed or “zeroed” to help make accurate and convenient movements.

Fine Down Feed

Turn counter-clockwise the knob (E, Fig. 50) to engage the fine down feed knob (G, Fig. 03) what located on the front of the head. Turn it according to you want to move downward, Clockwise turn the hand wheel to down feed the spindle, reverse to retract it.

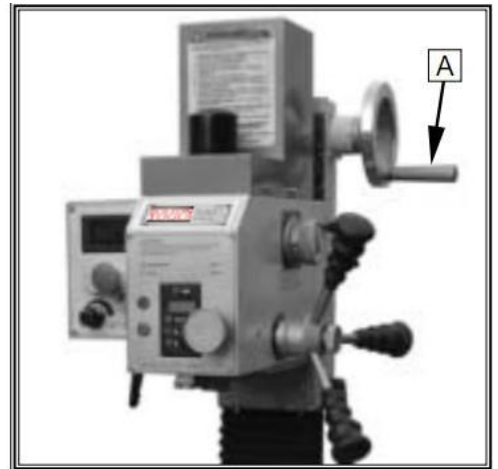

Fig. 48

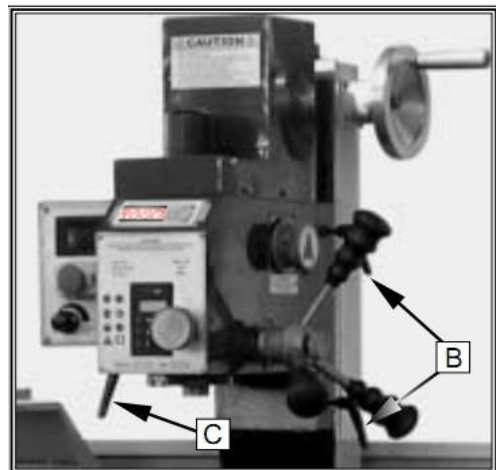

Fig. 49

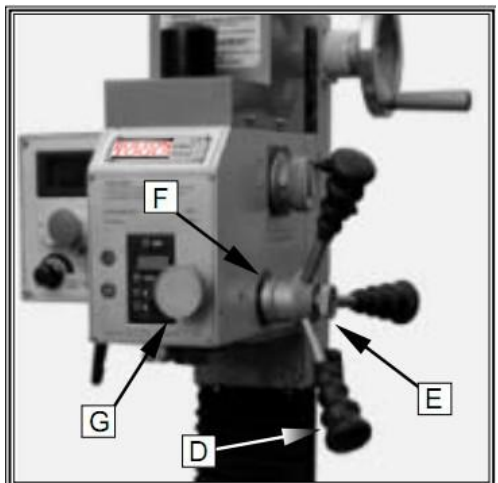

Fig. 50

Mill Head Rotation

The head is designed to tilt 90° either left or right, enabling it to perform task such as angle drilling or horizontal slotting. Loosen the lock nuts (H, Fig. 51) under the head. Rotate the head to its desired position, using the reference guide (I, Fig.51). Once in place, re-tighten the lock nuts.

Note: make sure to provide support for the head so it doesn't unexpectedly rotate on its own. Always maintain control of the head.

Keep in mind that the head must be dialed in when it's returned to the "zero" position if high levels of accuracy are required. If you are able to use an angle vise to accomplish your milling operation without tilting the mill head, you will save yourself a good amount of set-up time.

High/Low Speed Knob (J, Fig. 52)

Located on the right of the mill head. You can select H/L speed by moving the knob right or left. **Note: Change speed keep machine is at low speed!** See the chart below for spindle speeds:

SPINDLE SPEED  /min	
L	H
50-1125	100-2250

Caution: Even at low spindle speeds, metal fragments from the cutting process can be expelled by the mill/drill. Always wear eyewear and protective clothing when operating the machine!

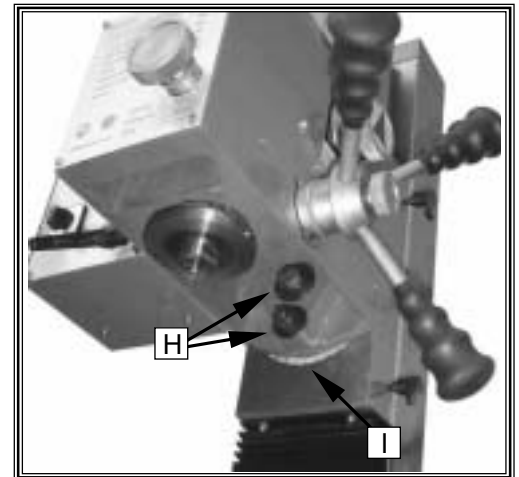

Fig. 51

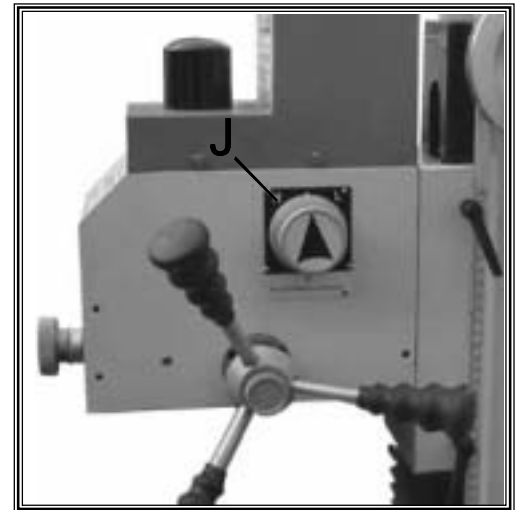

Fig. 52

Electrical Connections

WARNING!
A qualified electrician must make all electrical connections!
Failure to do so may cause serious injury!

Before connecting the machine to the mains, make sure that the electrical values of the mains supply are the same as those for the machine's electrical components. Use the wiring diagram (Fig. 53) for connecting the lathe to the mains supply.

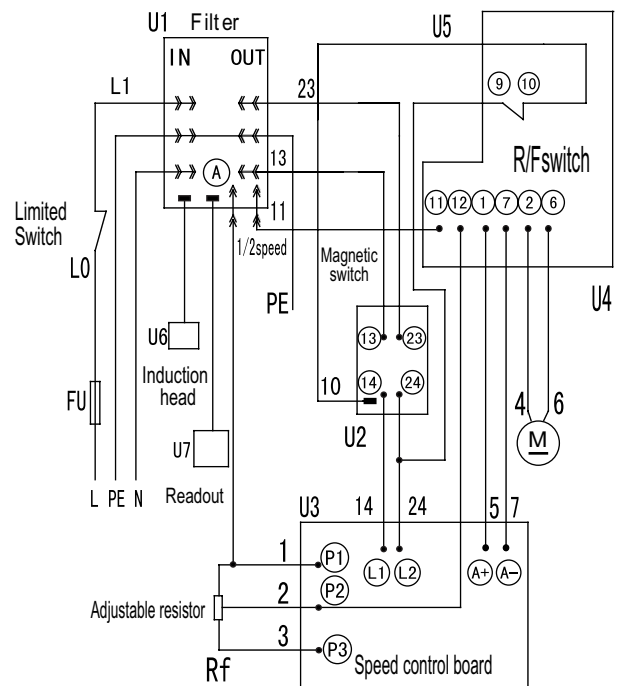

Fig. 53

WARNING!

**Make sure the machine is properly ground!
Failure to do so may cause serious injury and
damage to user!**

DC-Motor - 600W 110V

Make sure that all 2 phase (L, N) are connected.
Defective or incorrect connection will render the
guarantee null and void.
Indicators are:
Motor runs hot immediately (3-4 minutes).
Motor doesn't run silently and has no power.

Magnetic Switch (A, Fig.54) has the function of
emergency stopping and the protective function to the
machine and electric components. Green push button
marked "I" to start the motor, Red push button
marked "O" to switch the motor off.

Speed Control Knob (B, Fig. 54) turn it clockwise to
increase the spindle speed, reverse to decrease. The
knob should be turned to zero each time the machine
is stopped. Always start the machine with the knob
set at zero.

F/R switch (C, Fig. 54) changing the position of switch
will reverse the direction of the motor. F-forward
direction, R- reverse direction.

Fuse Base (D, Fig. 55) located on the back plate of
electrical box. Fuse what rate is 8A is put in the base.
Turn counter-clockwise the button to open and
change the fuse, reverse to retighten.

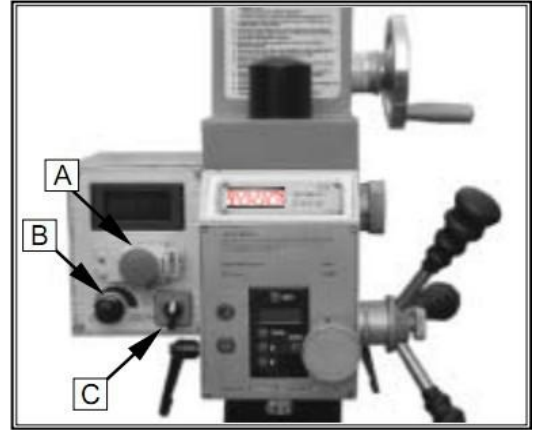

Fig.54

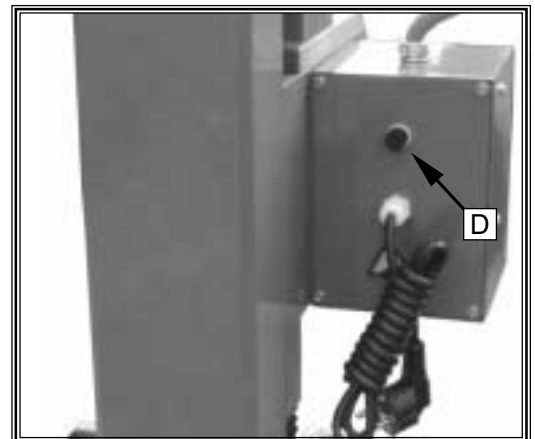

Fig.55

⚠ WARNING!

**This machine is designed and intended for use
by properly trained and experienced personnel
only! If you are not familiar with the proper and
safe use of mill/drills, don't use the machine
until proper training and knowledge have been
obtained!**

Arbor Replacement

1. Disconnect machine from the power source, unplug.
2. Remove the cover of drawbar onto the motor cover (A, Fig. 56).
3. Hold the flat of spindle (B, Fig. 57) to keep it from moving while loosening the drawbar (C, Fig. 58) with the 22-25 spanner in toolbox.
4. Loosen the drawbar approximately three to four full turns.
5. Tap the drawbar head with a rubber mallet to dislodge the arbor.
6. Grasp the arbor with one hand while loosening the drawbar with the other. Continue to loosen the drawbar until the arbor can be withdrawn from the spindle. Wipe out the spindle with a clean dry rag.
7. Wipe down the new arbor with a clean dry rag and place the arbor into the spindle. Thread the drawbar into the arbor. Tighten the drawbar with a spanner while holding the spindle.

WARNING!

Do not loosen the drawbar more than three or four turns before hitting with a rubber mallet. Damage to the drawbar threads may occur!

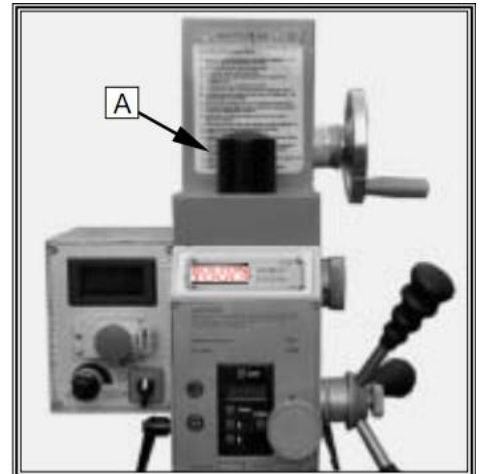

Fig. 56

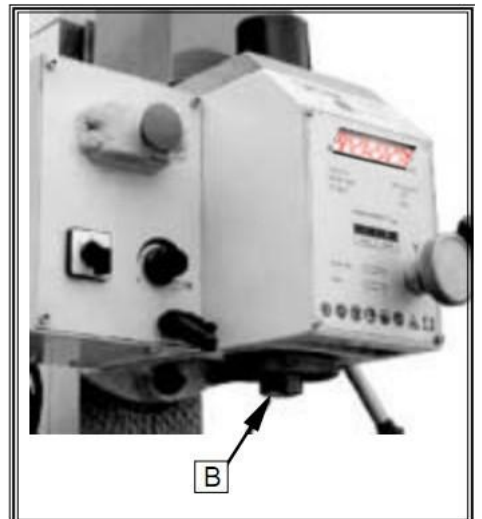

Fig. 57



Fig. 58

Gibs Adjustment

After a period of time, movement of the table over the ways will cause normal wear. Adjust the gibs to compensate for this wear.

1. The vertical gib adjustment screw (C, Fig.59) is found onto the column.
2. Loose the screw from small end of taper gibs. Turn the screw from large end of taper gibs slightly clockwise to tighten. Turn the handwheels and check the tension.
3. Re-adjust as required.

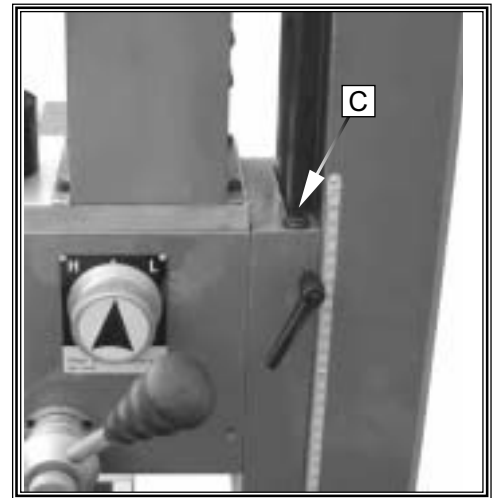

Fig. 59

Maintenance

Keep the maintenance of the machine tool during the operation to guarantee the accuracy and service life of the machine.

1. In order to retain the machine's precision and functionality, it is essential to treat it with care, keep it clean and grease and lubricate it regularly. Only through good care, you can be sure that the working quality of the machine will remain constant. **Disconnect the machine plug from the mains supply whenever you carry out cleaning, maintenance or repair work!**
2. Lubrication all slideways lightly before every use. The leadscrew must also be lightly lubricated with lithium base grease.
3. During the operation, the chips what falls onto the sliding surface should be cleaned timely, and the inspection should be often made to prevent chips falling into sliding ways. Asphalt felt should be cleaned at certain time. **Do not remove the chips with your bare hands. There is a risk of cuts due to sharp-edged chips.**
4. After the operation every day, eliminate all the chips and clean different part of the machine and apply machine oil to prevent rusting.
5. In order to maintain the machining accuracy, take care of the arbor, drawbar, the surface of the worktable and the guide way and avoid mechanical damage and the wear due to improper guide.
6. If the damage is found, the maintenance should be done immediately.

Trouble Solution

Problem	Possible Cause	Solution
Too chatters	Gibs too loose on table, column Unused feeds not locked Mill head not locked Quill too loose Tool not on center Improper tool shape, tool dull	Readjust gibs Lock all axes but the one moving Lock mill head Tighten quill lock Center tool reshape, sharpen, or replace tool
Depth of cut is not consistent	Quill moving Setup wrong	Lock quill Make sure setup is parallel to table
Hole is off center or bit wanders	Bit dull Bit not mounted correctly in chuck Chuck loose in spindle Drawbar not secured Bearing loosen or worn Cutting too fast	Use sharp bits Remount tool Remount chuck on arbor Tighten drawbar Tighten or replace bearings Reduce speed
Bit turns erratically or stops	Bit fed into work too fast	Reduce feed rate
Chuck is difficult to tighten or loosen	Chuck sticking Debris in chuck	Apply lubricant Clean chuck
Chuck wobbles	Chuck loose on arbor Drawbar not tight	Clean arbor and remount Clean spindle and replace drawbar
Turn on machine and nothing happens	Machine unplugged Loose electrical connections	Plug in machine Tighten wiring connections

BPD290VF Headstock and Driving Assembly

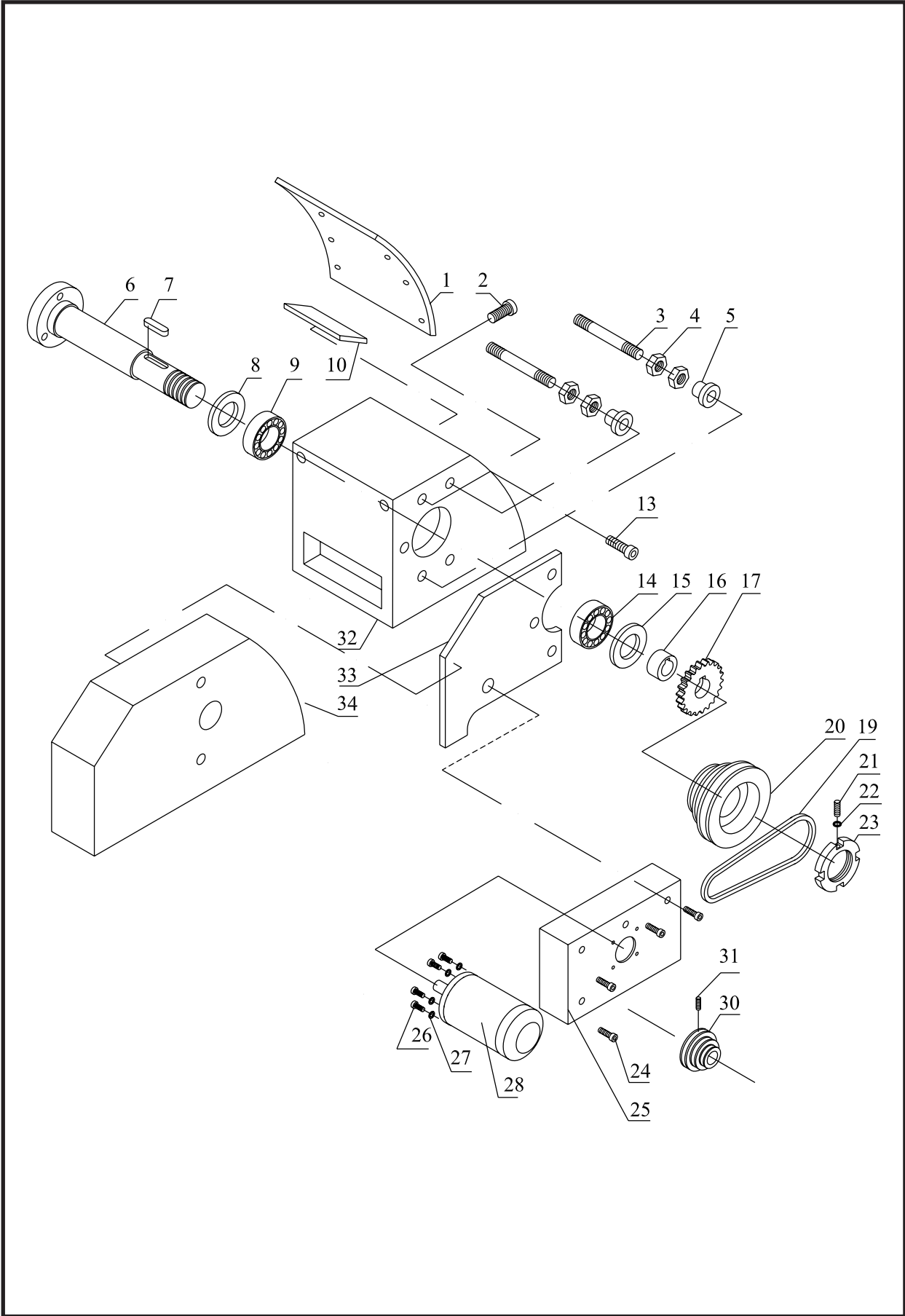

BPD290VF Headstock and Driving Assembly

No.	Parts No.	Description	Specification	Qty
1	1	Label		1
2	2	Screw	Φ4x10	6
3	3	Bolt		2
4	4	Nut	M10	4
5	5	Nut	M10	2
6	6	Spindle		1
7	7	Key	8x45	1
8	8	Gasket		1
9	9	Bearing		1
10	10	Headstock		1
13	13	Screw	M8x25	2
14	14	Bearing	2007109E	1
15	15	Gasket		1
16	16	Bush		1
17	17	Gear		1
18	19	Belt	Gates 730	1
19	20	Spindle Pulley		2
20	21	Set Screw	M5x12	1
21	22	Washer		2
22	23	Nut		1
23	24	Screw		4
24	25	Bracket		1
25	26	Screw		4
26	27	Washer		4
27	28	DC Motor	1.0KW	1
28	30	Motor Pulley		1
29	31	Set Screw		1
30	32	Head Stock		1
31	33	Belt Cover		1
32	34	Bracket Plate		1

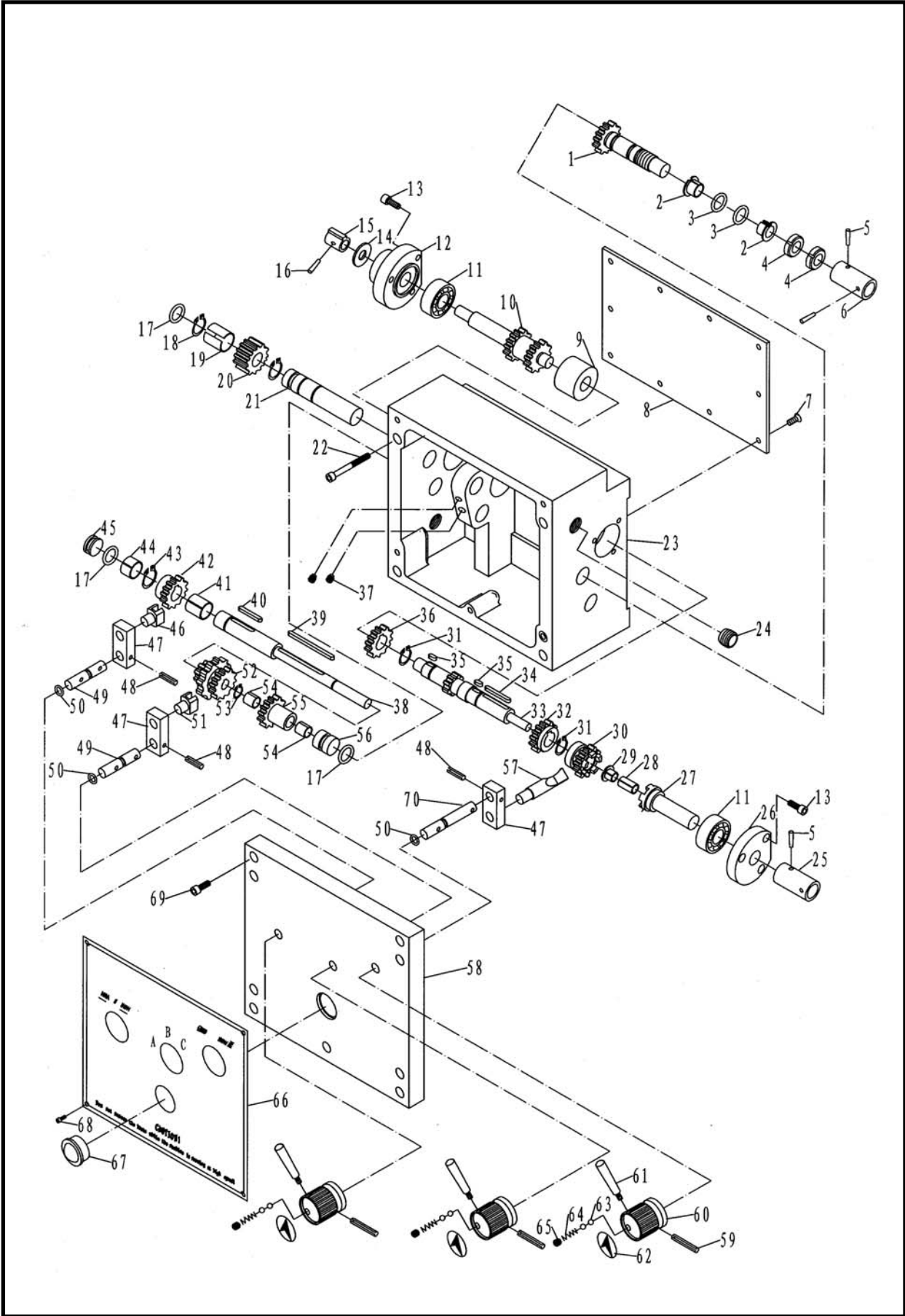

BPD290VF Gearbox Assembly (I)

No	Parts No.	Description	Specification	Qty
42	1	Shaft		1
43	2	Bearing	16170	2
44	3	O-Ring	18001400	2
45	4	Nut	M16x1.5	2
46	5	Pin	Φ3x22	2
47	6	Collar		1
48	7	Screw	M5x8	10
49	8	Cover		1
50	9	Collar		1
51	10	Gear		1
52	11	Bearing	6202	2
53	12	Left Plug		1
54	13	Hex Socket Cap Screw		6
55	14	Washer	Φ10	1
56	15	Key		1
57	16	Pin	Φ4x14	1
58	17	O-Ring	18001500	3
59	18	Snap Ring	Φ18	2
60	19	Bearing	1815	1
61	20	Gear		1
62	21	Shaft		1
63	22	Hex Socket Cap Screw	M6x50	4
64	23	Gearbox		1
65	24	Set Screw	M16x1.5x12	2
66	25	Collar		1
67	26	Right Plug		1
68	27	Shaft		1
69	28	Bearing	0815	1
70	29	Bearing	08075	1
71	30	Gear		1
72	31	Snap Ring	Φ15	2
73	32	Gear		1
74	33	Shaft		1
75	34	Key	4x25	1
76	35	Key	4x8	2
77	36	Gear		1
78	37	Set Screw		2
79	38	Shaft	Φ6x18	1
80	39	Key	4x50	1
81	40	Key	4x20	1
82	41	Bearing	1615	1
83	42	Gear		1
84	43	Snap Ring	Φ16	1
85	44	Bearing	1610	1

BPD290VF Top slide Cross slide , Carriage Assembly

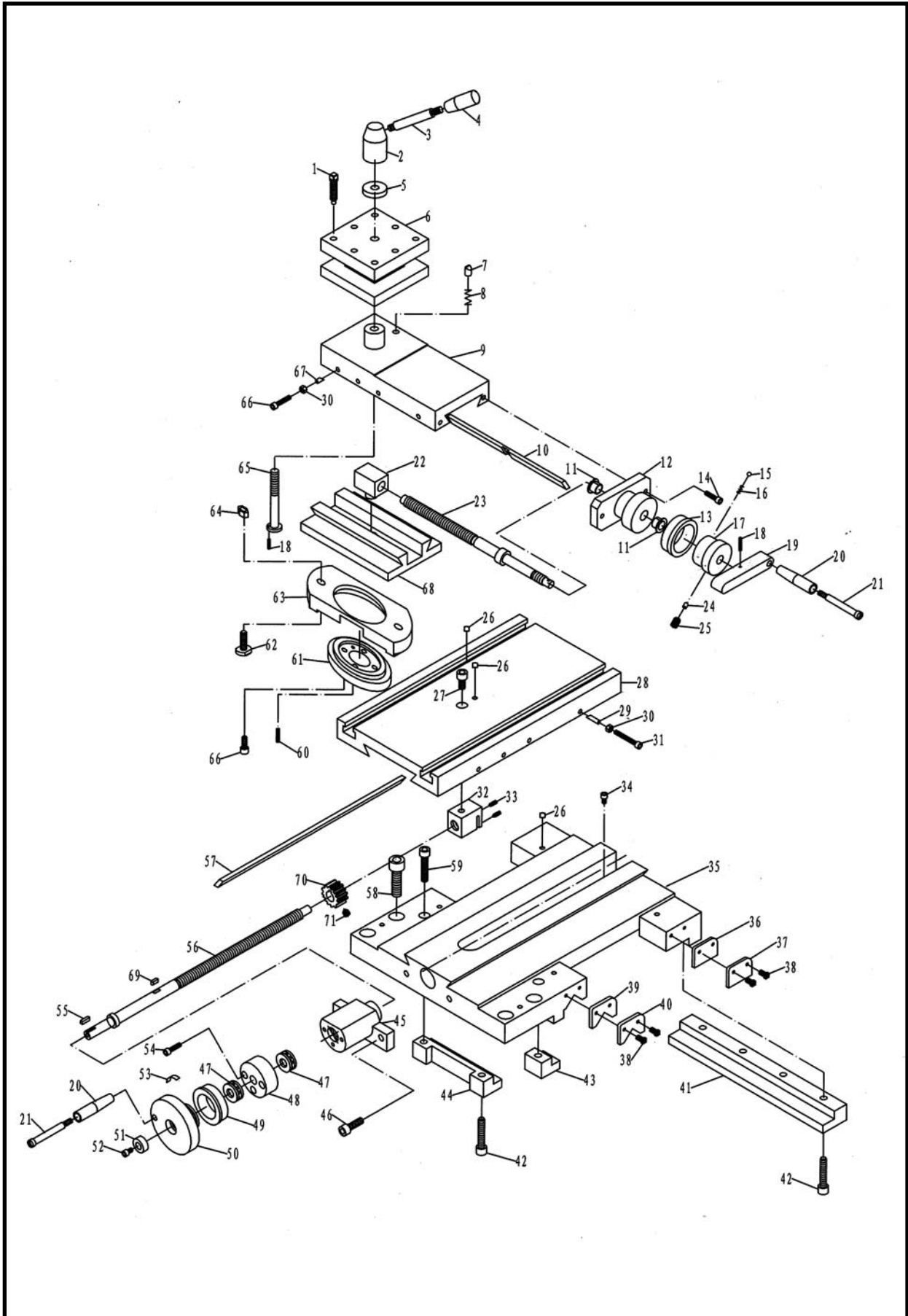

BPD290VF Top slide Cross slide , Carriage Assembly(I)

No	Parts No.	Description	Specification	Qty
112	1	Screw	M8x30	8
113	2	Handle Base		1
114	3	Handle Shaft		1
115	4	Knob		1
116	5	Washer		1
117	6	Post Base		1
118	7	Stop		1
119	8	Spring	7x0.8x11	1
120	9	Top Slide		1
121	10	Gib		1
122	11	Washer		2
123	12	Hub		1
124	13	Index Ring		1
125	14	Hex Socket Cap Screw	M6x20	2
126	15	Ball	Φ5	1
127	16	Spring	1.5x0.5x6.5	1
128	17	Index Base		1
129	18	Pin	Φ3x16	2
130	19	Lever		1
131	20	Lever		2
132	21	Lever Shaft		2
133	22	Block		1
134	23	Screw		1
135	24	plug		3
136	25	Set Screw	M6x10	3
137	26	Oil Ball		7
138	27	Hex Socket Cap Screw	M8x10	1
139	28	Cross Slide		1
140	29	plug		4
141	30	Hex Nut	M6	8
142	31	Hex Socket Cap Screw	M6x30	4
143	32	Block		1
144	33	Set Screw	M4x8	2
145	34	Hex Socket Cap Screw	M5x6	1
146	35	Saddle		1
147	36	Wiper		2
148	37	Plate		2
149	38	Screw	M4x18	8
150	39	Wiper		2
151	40	Plate		2
152	41	Strip		1
153	42	Hex Socket Cap Screw	M8x30	5
154	43	Strip		1
155	44	Strip		1

BPD290VF Apron Assembly

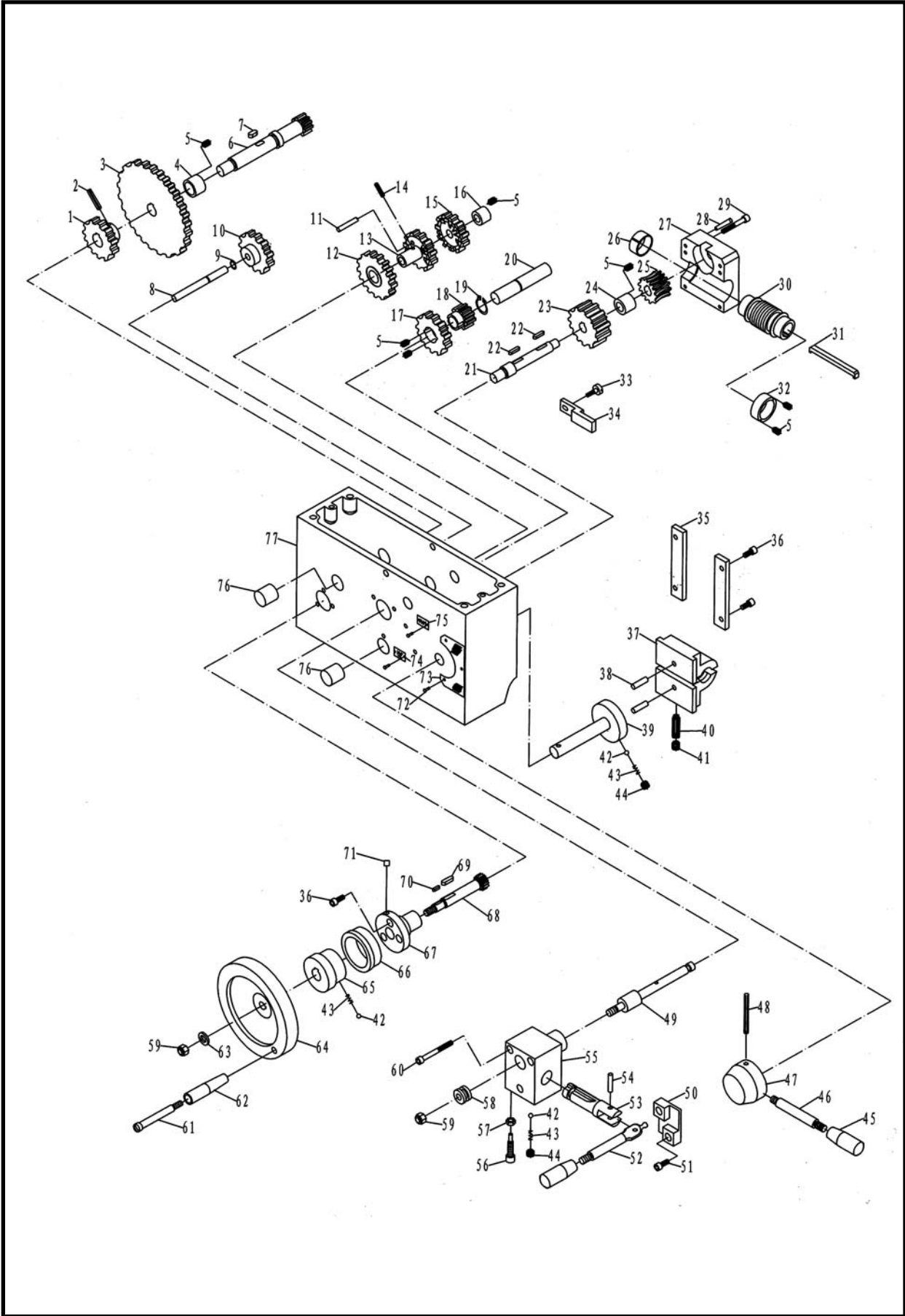

BPD290VF Apron Assembl(y)

No	Parts No.	Description	Specification	Qty
183	1	Gear		1
184	2	Pin	Φ5x24	1
185	3	Gear		1
186	4	Washer		1
187	5	Set Screw	M4x8	7
188	6	Gear Shaft		1
189	7	Key		1
190	8	Shaft		1
191	9	Snap Ring	Φ8	1
192	10	Gear		1
193	11	Shaft		3
194	12	Gear		1
195	13	Gear		1
196	14	Pin	Φ4x16	1
197	15	Gear		1
198	16	Washer		1
199	17	Gear		1
200	18	Gear		1
201	19	Snap Ring	Φ15	1
202	20	Shaft		1
203	21	Worm		1
204	22	Key	5x14	2
205	23	Gear		1
206	24	Washer		1
207	25	Worm		1
208	26	Bearing	2501	1
209	27	Worm Base		1
210	28	Pin	Φ4x20	2
211	29	Hex Socket Cap Screw	M4x30	4
212	30	Worm		1
213	31	Key		1
214	32	Washer		1
215	33	Set Screw		1
216	34	Plate		1
217	35	Plate		2
218	36	Hex Socket Cap Screw	M5x12	7
219	37	Half Nut		1
220	38	Pin	Φ6x18	2
221	39	Cam Shaft		1
222	40	Hex Socket Cap Screw	M6x20	1
223	41	Hex Socket Cap Screw	M6x8	1
224	42	Ball	Φ5	3
225	43	Spring	0.7x4x10	3
226	44	Set Screw	M6x6	2

BPD290VF Tailstock, Bed Assembly

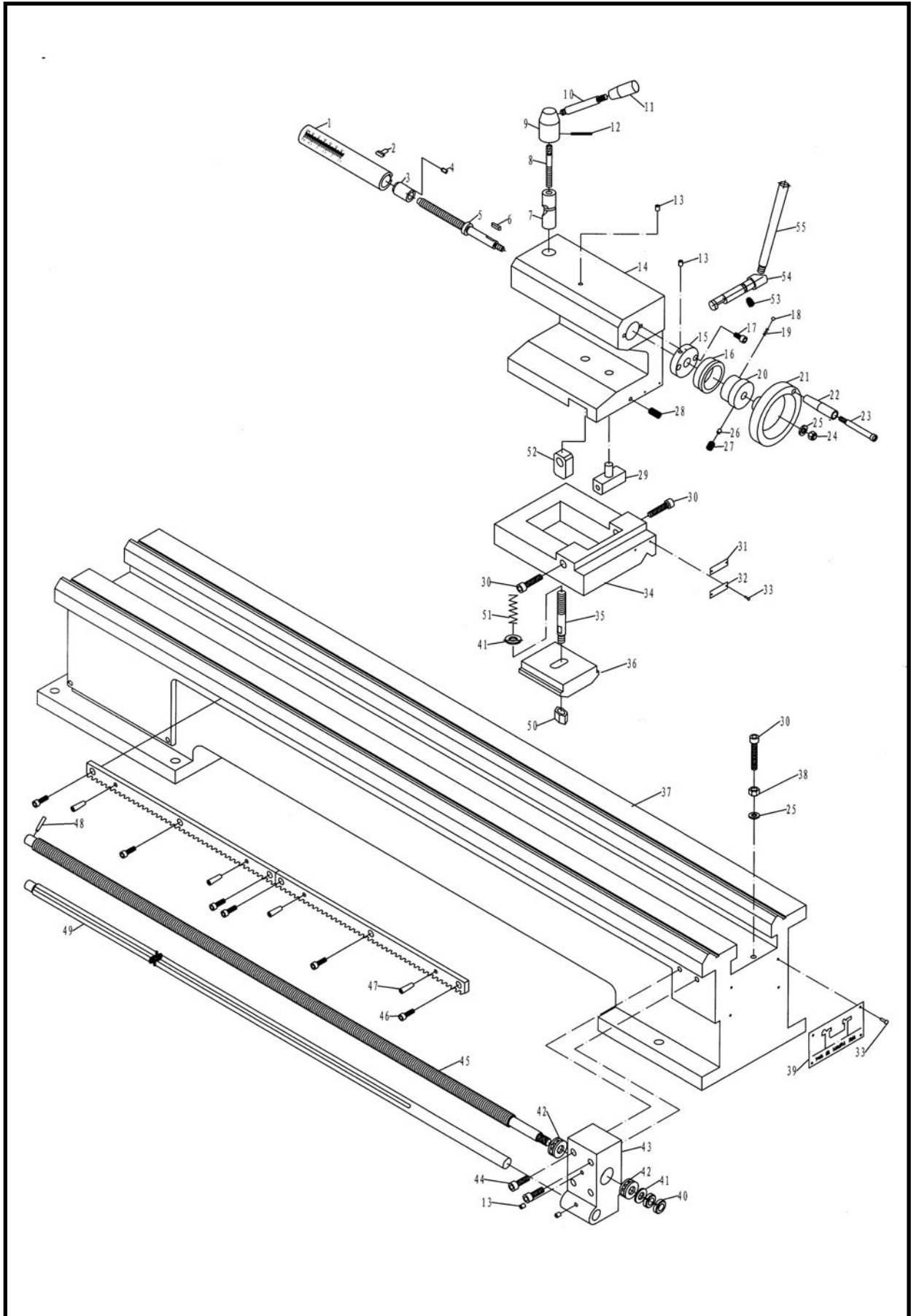

BPD290VF Tailstock, Bed Assembly (I)

No	Parts No.	Description	Specification	Qty
260	1	Quill		1
261	2	Key		1
262	3	Nut		1
263	4	Set Screw	M6x10	1
264	5	Screw		1
265	6	Key	4x10	1
266	7	Pivot Block		1
267	8	Screw		1
268	9	Handle Base		1
269	10	Handle Shaft		1
270	11	Knob	M8	1
271	12	Pin	Φ3x30	1
272	13	Oil Ball	Φ6	4
273	14	Tailstock body		1
274	15	Flange Cover		1
275	16	Index Ring		1
276	17	Hex Socket Cap Screw	M6x10	2
277	18	Ball	Φ4	1
278	19	Spring	Φ4x1x6	1
279	20	Sleeve		1
280	21	Handwheel		1
281	22	Knob		1
282	23	Screw		1
283	24	Nut	M8	1
284	25	Washer	Φ8	6
285	26	Brake Block		1
286	27	Hex Socket Cap Screw	M6x10	1
287	28	Hex Socket Cap Screw	M6x16	1
288	29	Set Screw		1
289	30	Hex Socket Cap Screw	M8x40	3
290	31	Plate		1
291	32	Plate		1
292	33	Rivet	Φ2x6	8
293	34	Base		1
294	35	Bolt		1
295	36	Clamping Plate		1
296	37	Bed		1
297	38	Nut	M8	5
298	39	Plate		1
299	40	Nut	M12x1.25	2
300	41	Washer	Φ12	2
301	42	Bearing	51102	2
302	43	Bracket		1
303	44	Hex Socket Cap Screw	M8x20	2

BPD290VF ELECTRICAL BOX ASSEMBLY

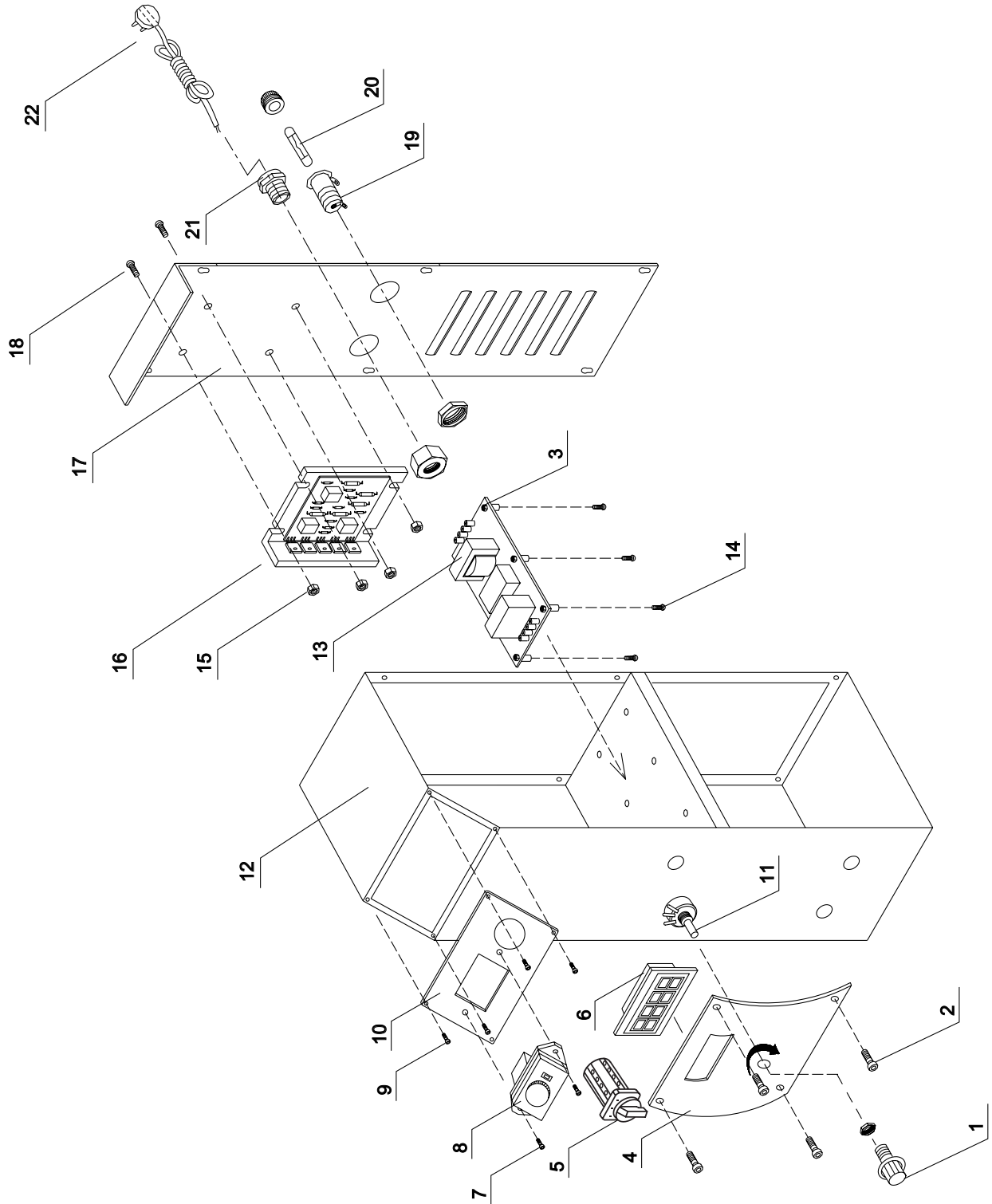

BPD290VF - Mill head Assembly

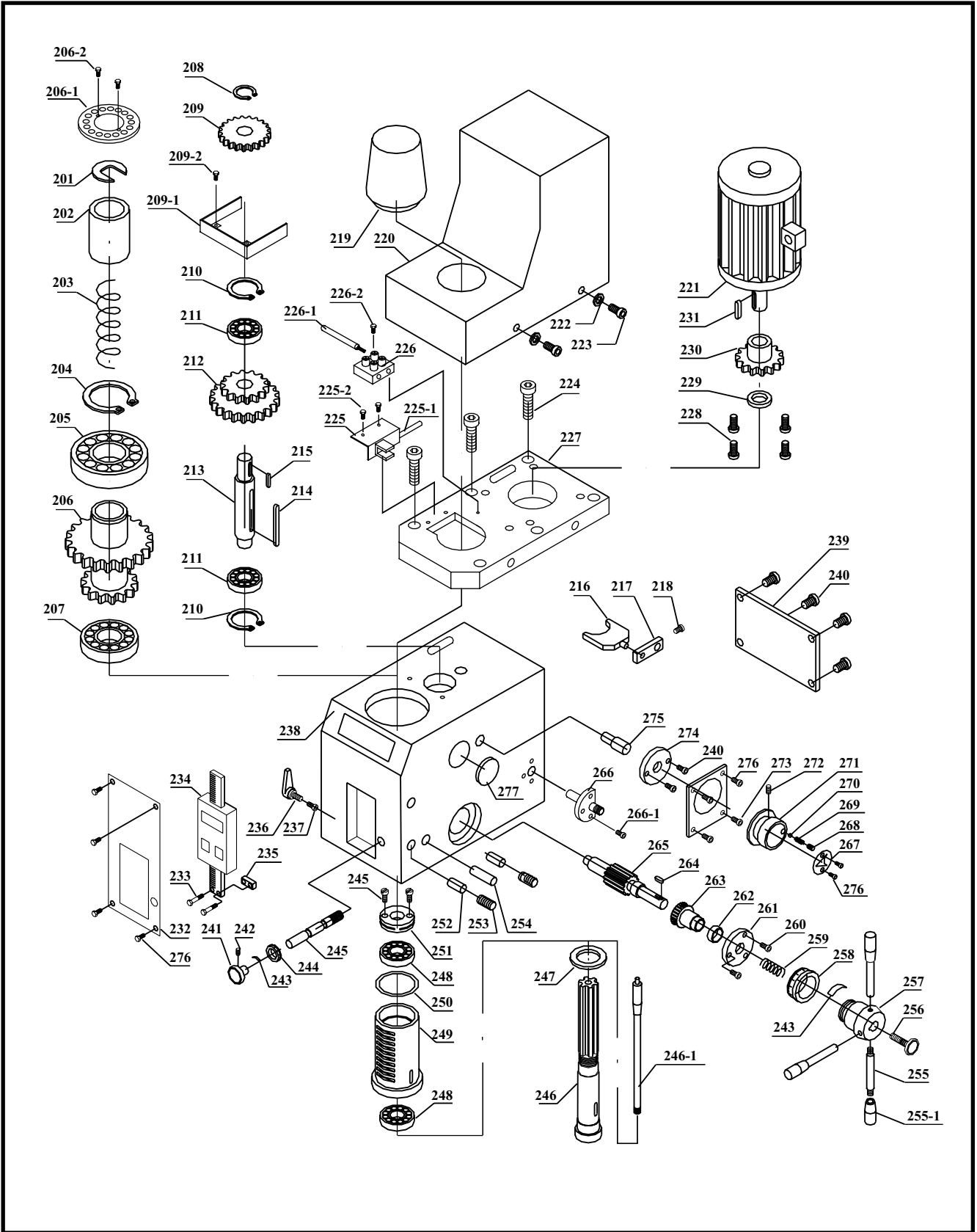

BPD290VF– MILL HEADASSEMBY I

No.	Parts No.	Description	Specification	Qty
1	201	Position Washer		1
2	202	Bush		1
3	203	Spring	2.5x28x100	1
4	204	Snap Ring	Φ 45	1
5	205	Bearing	6209	1
6	206	Gears	60/70T	1
7	206-1	Raster Ring	16 Bore	1
8	206-2	Screw	M3x8	2
9	207	Bearing	7007	1
10	208	Snap Ring	Φ 15	1
11	209	Gears	37T	1
12	209-1	Guard		1
13	209-2	Screw	M3x6	2
14	210	Snap Ring	Φ 32	2
15	211	Bearing	6002	2
16	212	Shafting Gear	42/62T	1
17	213	Shaft		1
18	214	Key	5X50	1
19	215	Key	C5x12	1
20	216	Fork		1
21	217	Fork Arm		1
22	218	Set Screw	5x8	1
23	219	Drawbar Cover		1
24	220	Motor Cover		1
25	221	Motor	91ZYT005	1
26	222	Washer	M4x8	6
27	223	Washer	M4	6
28	224	Screw	M6x14	6
29	225	Bracket for finder		1
30	225-1	Electrical wire		1
31	225-2	Screw	M3x6	2
32	226	Terminal		1
33	226-1	Electrical wire		1
34	226-2	Screw	M3x12	1
35	227	Motor Plate		1
36	228	Screw	M5x12	6
37	229	Snap Ring	M10	1
38	230	Gear	25T	1
39	231	Key	C4X6	1
40	232	Label		1
41	233	Screw	M3x6	2
42	234	Digital Scale		1

BPD290VF – MILL HEAD ASSEMBY II

No.	Parts No.	Description	Specification	Qty
43	235	Base		1
44	236	Locking Lever	M8x20	1
45	237	Brass Pin		1
46	238	Mill Head		1
47	239	Plate for Head		1
48	240	Screw	M4x8	6
49	241	Knob		1
50	242	Set Screw	M5x6	1
51	243	Spring Piece		2
52	244	Dial		1
53	245	Worm Shaft		1
54	246	Spindle		1
55	246-1	Drawbar		1
56	247	Ring		1
57	248	Bearing		2
58	249	Sleeve		1
59	250	Rubber Ring	58x2.65	1
60	251	Adjusted Nut		1
61	252	Brass Pin	B4x20	4
62	253	Set Screw	M5X12	4
63	254	Pin	A6x30	1
64	255	Handle		3
65	256	Knob		1
66	257	Base		1
67	258	Dial		1
68	259	Spring	1.2x12x2.5	1
69	260	Screw	M4X40	3
70	261	Flange		1
71	262	Washer		1
72	263	Worm Gear		1
73	264	Key	4x12	1
74	265	Gear Shaft		1
75	266	Flange		1
76	266-1	Screw	4x12	3
77	267	H/L Speed Indication Label		1
78	268	Set Screw	M8x8	1
79	269	Spring	0.8x5x25	1
80	270	Ball	Φ 6.5	1
81	271	Knob		1
82	272	Set Screw	M5x16	1
83	273	H/L Speed Label		1
84	274	Flange		1
85	275	Fork Shaft		1

BPD290VF - Column, Assembly

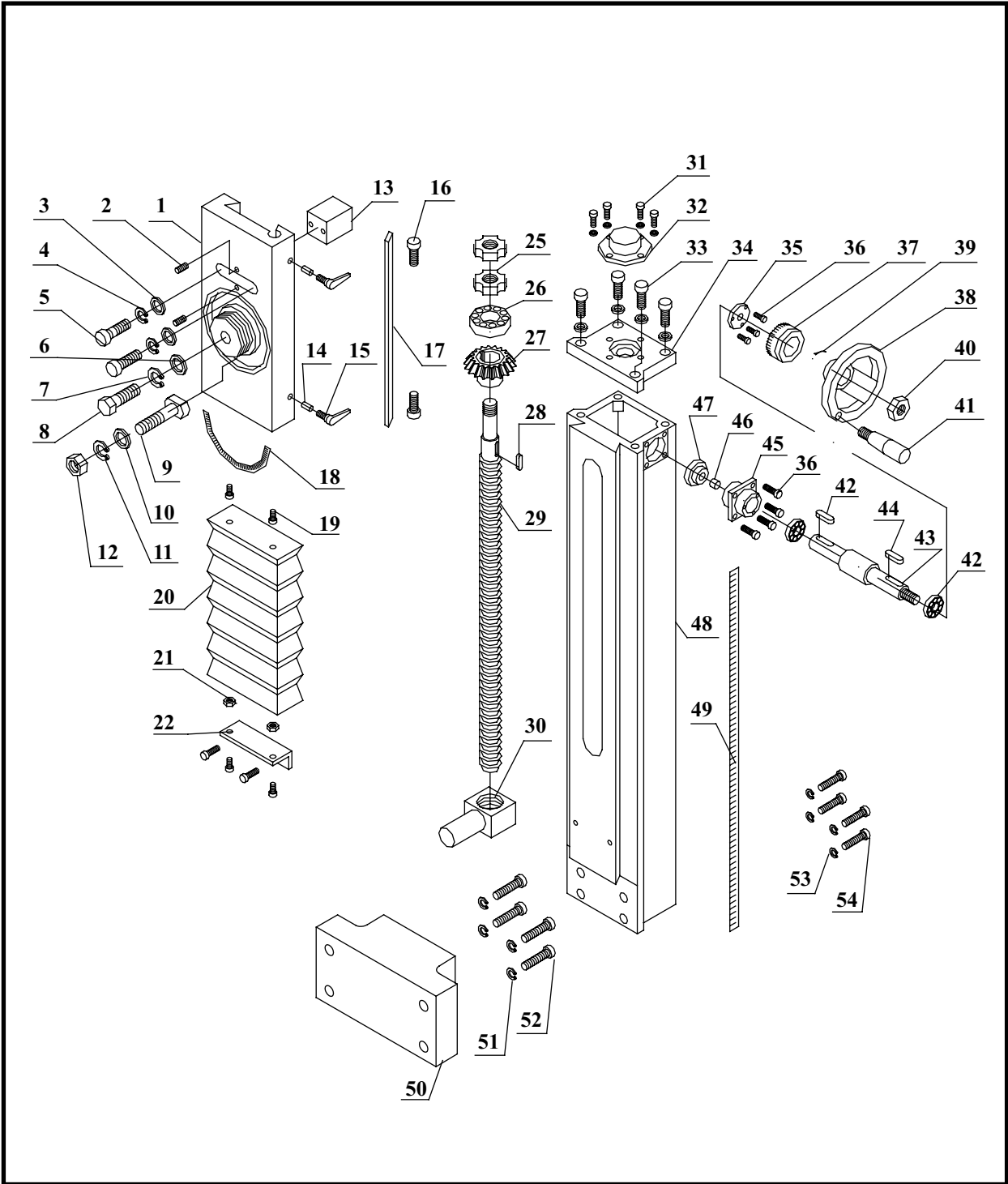

BPD290VF – COLUMN, ASSEMBLY

No.	Parts No	Description	Specification	Qty
86	1	Vertical Slide		1
87	2	Screw	M6x16	2
88	3	Washer		2
89	4	Spring Washer	8	2
90	5	Screw	M8x25	2
91	6	Screw	M12x40	1
92	7	Spring Washer	12	5
93	8	T-Nut	12	1
94	9	Bolt		1
95	10	Washer	M10	1
96	11	Spring Washer	M10	1
97	12	Nut	M10	1
98	13	Block		1
99	14	Brass Pin		5
100	15	Locking Lever	M6x16	5
101	16	Gib Screw		1
102	17	Gib		1
103	18	Angie Indication Label		1
104	19	Screw	M5x10	12
105	20	Dust Cover		1
106	21	Nut	M5	2
107	22	Connect Rib		1
108	23	Dust Cover		1
109	24	Connect Rib		1
110	25	Nut	M16x1.5	2
111	26	Bearing		1
112	27	Gear		1
113	28	Key	4x16	2
114	29	Vertical Leadscrew		1
115	30	Nut		1
116	31	Washer	M5	4
117	32	Cover		1
118	33	Screw	M8x20	4
119	34	Bracket		1
120	35	Flange		1
121	36	Screw	M5x12	7
122	37	Dial		1
123	38	Spring Piece		4
124	39	Handwheel		1
125	40	Locking Nut		4
126	41	Handle	M10x80	1
127	42	Bearing	6001	2
128	43	Shaft		1
129	44	Key	4x12	2
130	45	Bearing Housing		1
131	46	Bush		
132	47	Gear		1
133	48	Column		
134	49	Label	A5x25	1
135	50	Connect Base		1
136	51	Spring Washer	8	4
137	52	Screw	M12x90	4
138	53	Spring Washer	8	4
139	54	Screw	M12x90	4

BPD290VF – ELECTRICAL BOX ASSEMBLY

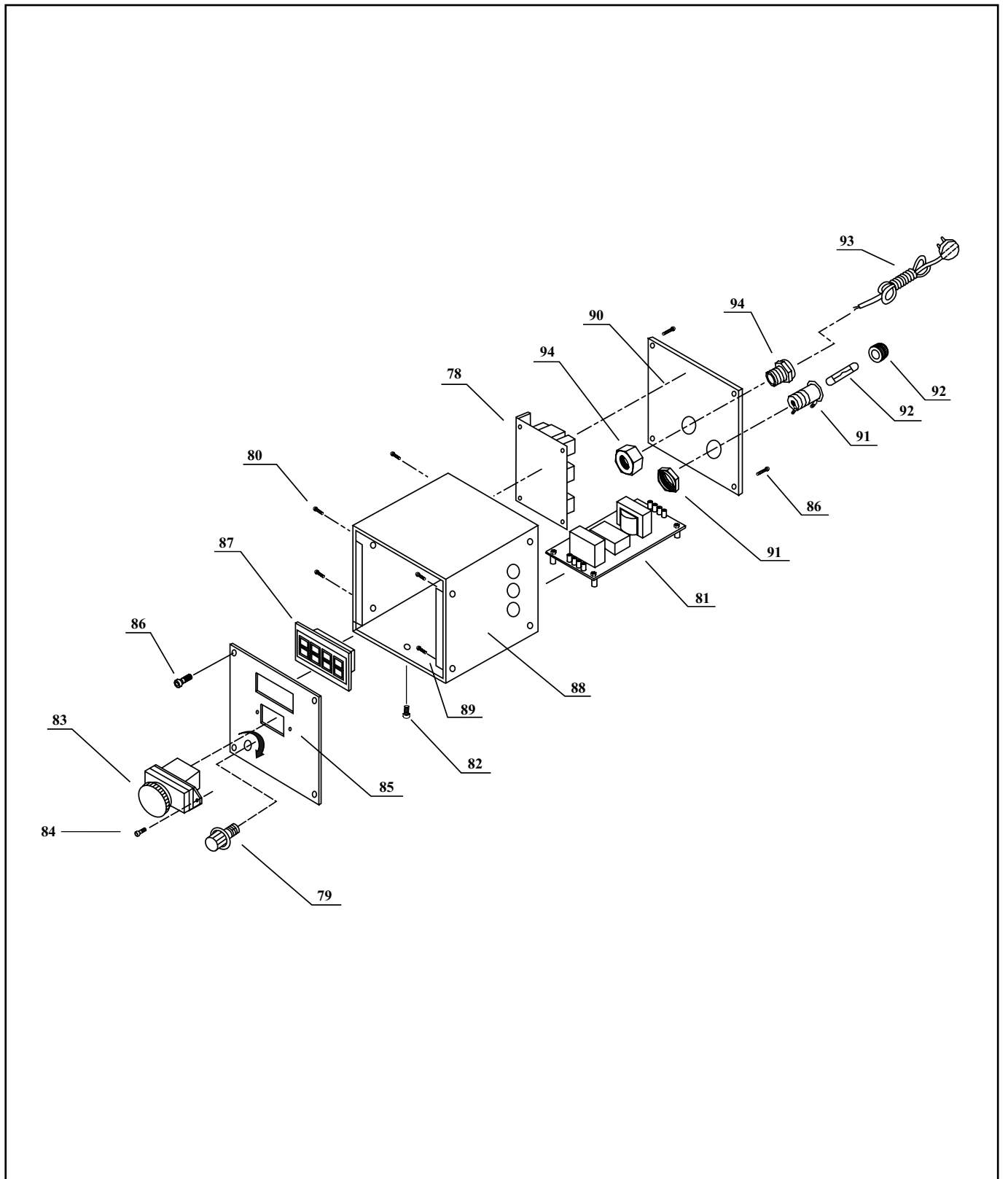

BPD290VF – ELECTRICAL BOX ASSEMBLY

No.	Parts No.	Description	Specification	Qty
1	78	Speed Control		1
2	79	Timing Knob		1
3	80	Screw	M3x8	4
4	81	Filter		1
5	82	Screw	M3x16	4
6	83	Magnetic Swich		1
7	84	Screw	M4x10	2
8	85	Electrical Plate		1
9	86	Screw	M4x6	8
10	87	Speed Display		1
11	88	Electrical Box		1
12	89	Screw	M5x8	4
13	90	Cover		1
14	91	Fuse Holder		1
15	92	Fuse (10A)		1
16	93	Plug		1
17	94	Strand Relief		1