PLATE COMPACTOR

60

OPERATING INSTRUCTIONS



⚠ WARNING

To reduce the risk of injury, all operators and maintenance personnel must read and understand these instructions before operating, changing accessories, or performing maintenance about this power equipment. All possible situations cannot be covered in these instructions. Care must be exercised by everyone using, maintaining or working near this equipment.

• Vibrator assembly parts list

ITEM NO.	PART NO.	DESCRIPTION	QUANTITY
1	1000501	Packing	2
2	1000502	Case cover/pulley	1
3	1000503	Washer, lock M8	8
4	1000504	Hexagonal bolt M8x25	8
5	1000505	Cover seal, vib.	1
6	1000506	Ecc. rotary shaft	1
7	1000507	Key 8x7x18	1
8	1000508	Pulley, driven	1
9	1000509	Washer 11x40x2.5	1
10	1000510	Washer, lock M10	1
11	1000511	Hexagonal bolt M10x40	1
12	1000512	Oil seal	1
13	1000513	Case cover/shut-off	1
14	1000514	Bearing 6211	2
15	1000515	Hexagonal bolt M16x40	4
16	1000516	Washer, lock M16	4
17	1000517	Washer, plat M16	4
18	1000518	Vibrating case	1
19	1000519	Plug, oil M12x1.25x20	1
20	1000520	Washer, copper M12	1

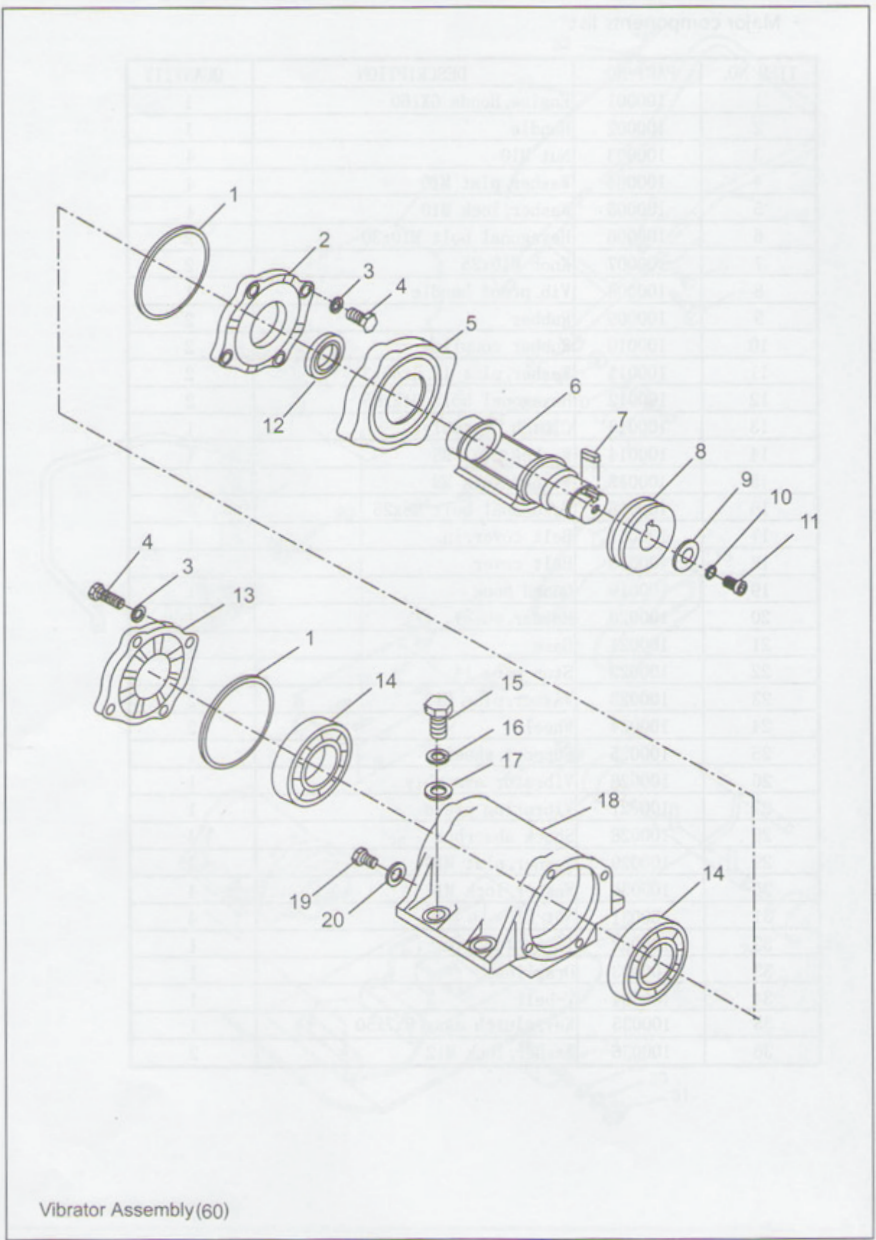

CONTENTS

Introduction2
 Applications2
 Structure2
 Functions and controls3
 Accessories3
 For safety operation3
 Hazards and risks4
 Operation4-9
 Care and preventive maintenance9
 Service9
 Specifications10
 Spare parts and service10
 Replacement parts list10-14

INTRODUCTION

Thank you for your selection of the power equipment.
 We have taken care in the design, manufacture and testing of this product. Should service or spare parts be required, prompt and efficient service is available from our branches.

General Safety Instructions for the Operation of Power Equipment
 Our factory's goal is to produce power equipment that helps the operator work safely and efficiently. The most important safety device for this or any tool is the operator. Care and good judgement are the best protection against injury. All possible hazards cannot be covered here, but we have tried to highlight some of the important items, individuals should look for and obey Caution, Warning and Danger signs placed on equipment, and displayed in the workplace. Operators should read and follow safety instructions packed with each product.

Learn how each machine works. Even if you have previously used similar machines, carefully check out each machine before you use it. Get the "feel" of it and know its capabilities, limitations, potential hazards, how it operates, and how it stops.

APPLICATIONS

Plate compactor is the machine that compacts the ground and it intends to make the surface smooth, by transmitting vibration through vibrating plate, which power generated from single motor in vibrator case. This machine is suitable for making the ground surface smooth, such as leveling the soil and beaching, finishing the asphalt paving. Applications as followings:

- | | |
|-------------------|-------------------|
| Trench compaction | Earthworks |
| Road maintenance | Landscaping |
| Brickpaving | Driveway toppings |

! Warning for incorrect application and abuse

This machine is hard to move forward on a soil with much water (especially clay soil). It is not suitable for such application. This machine is difficult to level a ground include big stones due to insufficient compacting force. Plate compactor is mainly applied for compacting surface smooth and it is nor effective for jobs that requires heavy compaction. In case of compacting ground deeply into lower layer, it is recommended to use Tamping Rammer, Vibro Compactor and Vibration Roller which compacting force is rather effective. Please use this compactor for compacting surface on soil, sediment, sand, beaching and asphalt. It is not recommended for use this machine for any other applications.

STRUCTURE

The upper part is made up of Power source, Handle, Belt Cover and Guard hook which are fixed by Engine base. The Engine base is fixed on Vibrating Plate by Shock absorbing Rubber. The lower part is made up of Vibrating plate and Vibrator unit that has an Eccentric rotary shaft built in. The power source is transmitted from the centrifugal clutch on engine output shaft to the Eccentric rotary shaft via V-belt.

Power Transfer

Air-cooled Single cylinder Engine is mounted as power source and Centrifugal Clutch is fixed on engine output shaft. Petrol Engine(2 cycle, 4 cycle) and Diesel Gasoline Engine can be mounted as option. Centrifugal Clutch engages by running up the engine and engine R.P.M. is reduced to suitable number for compacting. The rotation of engine is transmitted from V-pulley integrated with Clutch drum to Vibrator pulley through V-belt. Vibrator Pulley rotates Eccentric rotor shaft that is contained in Vibrator case. The generated vibration created from eccentric rotor is transmitted to Compaction with the weight of the machine makes the compaction of the ground possible.

FUNCTIONS AND CONTROLS

Motor

The motor is controlled by an ON/OFF switch or push button which is mounted on the motor below the fuel tank.

The motor speed is controlled by a remote throttle lever which is mounted on the machine handle.

Honda and Kama motors are fitted with an oil alert device which will stop the motor or prevent starting when the crankcase oil level falls below a safe level

Drive belt

Tension of the drive belt is adjustable. Loosen the four nuts on the bolts which secure the motor to the baseplate, Adjust the set screws which bear against the motor crankcase to achieve the required belt tension. Ensure that the four nuts and the set screw locknuts are tightened after adjustment.

ACCESSORIES

Transport Trolley - facilitates handling. Hooks into the baseplate. Fitted with 200mm rubber tyres.

FOR SAFETY OPERATION

! This safety alert symbol identifies important safety messages throughout this manual and on the machine. When you see this symbol, carefully read the message that follows. Your safety is at stake!

Foreword:

It is important to read this manual carefully so that you will fully understand the operational characteristics and performance of the plate compactor. Proper maintenance procedures will insure long life and top performance of the unit.

Safety:

This section outlines basic safety procedures that apply to the operation, maintenance and adjustment of the plate compactor. This unit is designed as a powerful, productive machine that should be operated with respect and caution.

Misuse or carelessness can result in serious injury or property damage, or both. Safety precautions must be observed at all times.

Operator Qualifications:

Before operating this equipment, an individual should read this manual. Whenever possible, he should be shown how to operate the unit by an experienced operator. Inexperience is hazardous in operating any machine or attachment. Trial and error is not the way to become familiar with a piece of equipment. This is expensive, cuts equipment life and can create machine downtime. Inexperience can cause injury or death. The machine should not be left unattended when operating.

General Safety:

! CAUTION

Protection required. Wear hard hat, shatterproof glasses, steel toed boots and other protective devices required by job conditions. Avoid jewelry or loose clothing. These many catch on controls or in moving parts and cause serious injury.

Starting Safety:

! CAUTION

Poisonous fumes. Start and operate only in well ventilated area. Breathing exhaust gases can result in sickness or death.

Servicing Safety:

! CAUTION

Flammable liquid. Stop engine and do not smoke or allow work in immediate area when refueling. Fire or explosion could result from flames or sparks.

Moving parts. Shutdown engine before performing. Service or maintenance. Contact with moving parts can cause serious injury.

Fligh temperature. Allow machine and engine to cool before performing service or maintenance. Contact with hot components can cause serious burns.

Engine

See engine operations manual

SHUTDOWN

EMERGENCY SHUTDOWN

Move throttle lever to "OFF" position and also turn stop switch to "OFF".

NORMAL SHUTDOWN

Move throttle lever quickly from "ON" to "OFF" and run engine for 3 to 5 minutes at low speed. After engine cools, turn stop switch to "OFF" position. Close fuel shut-off valve.

Major components list

ITEM NO.	PART NO.	DESCRIPTION	QUANTITY
1	100001	Engine, Honda GX160	1
2	100002	Handle	1
3	100003	Nut M10	4
4	100004	Washer, plat M10	4
5	100005	Washer, lock M10	4
6	100006	Hexagonal bolt M10x30	2
7	100007	Knob M10x25	2
8	100008	Vib. proof handle	1
9	100009	Rubber	2
10	100010	Rubber coupling	2
11	100011	Washer, plat 12.5x40x3	2
12	100012	Hexagonal bolt M12x65	2
13	100013	Clutch assembly	1
14	100014	Washer, plat M8	1
15	100015	Washer, lock M8	1
16	100016	Hexagonal bolt M8x25	1
17	100017	Belt cover, in.	1
18	100018	Belt cover	1
19	100019	Guard hook	1
20	100020	Holder, wheel	1
21	100021	Base	1
22	100022	Stop ring 14	2
23	100023	Washer, plat M12	2
24	100024	Wheel	2
25	100025	Support, wheel	1
26	100026	Vibrator assembly	1
27	100027	Vibrating plate	1
28	100028	Shock absorber	4
29	100029	Washer, plat M10	4
30	100030	Washer, lock M10	4
31	100031	Nut M10	4
32	100032	Throttle lever	1
33	100033	Dragline	1
34	100034	V-belt	1
35	100035	Key, clutch assy 8x7x50	1
36	100036	Washer, lock M12	2

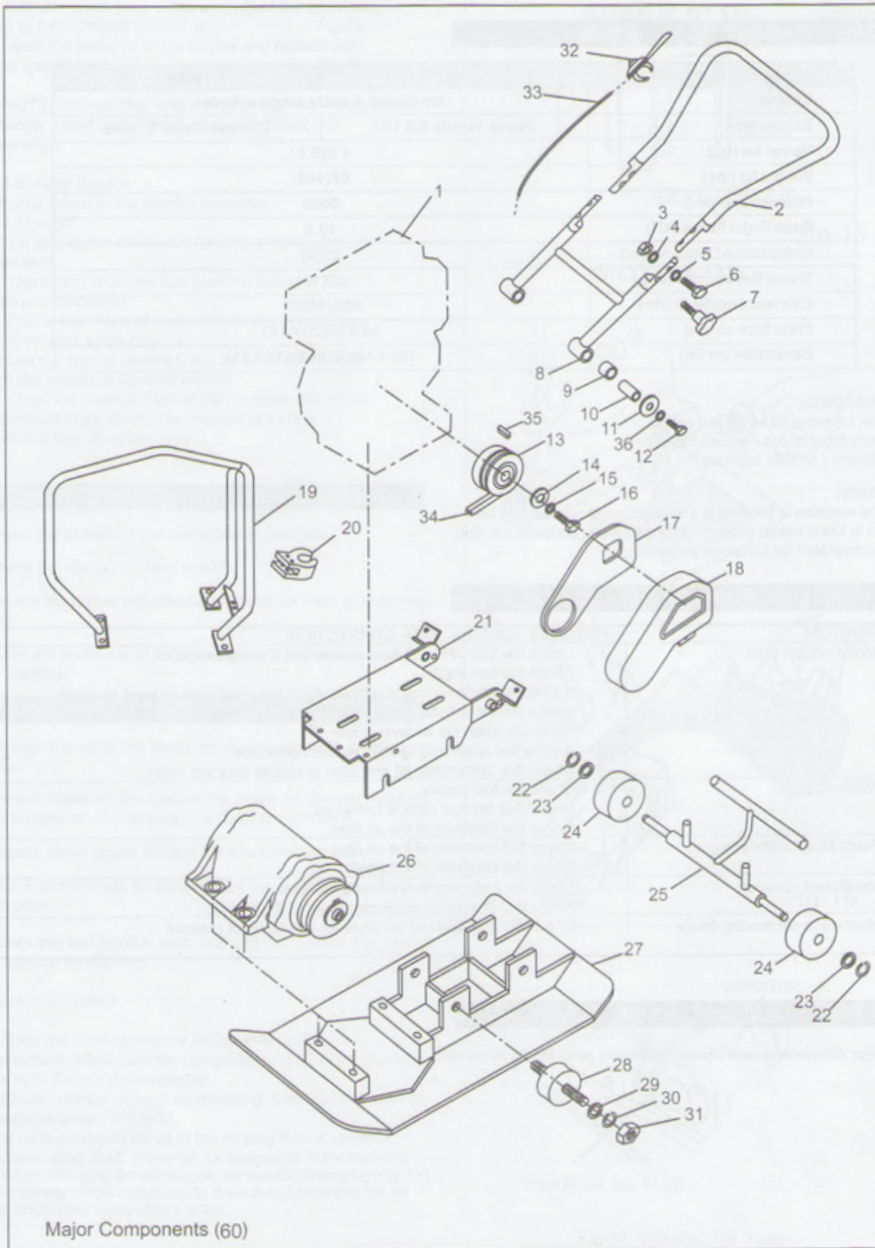

HAZARDS AND RISKS

NEVER allow any person to operate the machine without adequate instruction.

ENSURE all operators read, understand and follow the operating instructions.

SERIOUS INJURY could result from improper or careless use of this machine

Plate compactors are heavy units and should be positioned by two people of appropriate strength. Using the lifting handles provided on the machine, along with correct lifting techniques.

! MECHANICAL HAZARDS

DO NOT operate the machine unless all protective guards are in place.

KEEP hands and feet clear of rotating and moving parts as they will cause injury if contacted.

ENSURE that the motor operation switch is in the OFF position and the spark plug ignition lead is disconnected before removing the guards or making adjustments.

ENSURE both the machine and the operator are stable by setting up on level terrain and the machine will not tip over, slide or fall while in operation or unattended.

DO NOT leave the machine in operation while it is unattended.

ENSURE that the walls of a trench are stable and will not collapse due to the action of the vibration, prior to commencing compaction.

ENSURE that the area to be compacted does not contain any "live" electrical cables, gas, water or communication services which may be damaged by the action of the vibration.

EXERCISE CARE when operating unit. Exposure to vibration or repetitive work actions may be harmful to hands and arms.

NEVER stand on the unit while it is operating.

DO NOT increase the governed no-load motor speed above 3,500 r/min. Any increase may result in personal injury and damage to the machine.

BE CAREFUL not to come in contact with the muffler when the engine is hot, since it can cause severe burns.

ENSURE that repairs to the motor and machine are carried out personnel.

! FIRE & EXPLOSION HAZARDS

PETROL is extremely flammable and explosive under certain conditions.

ENSURE that petrol is only stored in an approved storage container.

DO NOT refuel the motor while it is in operation or hot.

DO NOT refuel the motor in the vicinity of sparks, a naked flame or a person smoking.

DO NOT over fill the fuel tank and avoid spilling petrol when refuelling. Spilled petrol or petrol vapour may ignite. If spillage occurs, ensure that the area is dry before starting the motor.

ENSURE that the fuel tank cap is securely fitted after refuelling.

! CHEMICAL HAZARDS

DO NOT operate or refuel a petrol or diesel motor in a confined area without adequate ventilation.

CARBON MONOXIDE exhaust gases from internal combustion motor driven units can cause death in confined spaces.

! NOISE HAZARDS

EXCESSIVE NOISE can lead to temporary or permanent loss of hearing.

WEAR an approved hearing protection device to limit noise exposure. As required by Occupational Health and Safety regulations.

PROTECTIVE CLOTHING

ALWAYS wear approved hearing protection when working in a confined work space. Protective goggles and a dust mask should be worn when working in a dusty environment. Protective clothing and footwear may also be desirable when working with hot mix bitumen.

! ADDITIONAL HAZARDS

Slip/Trip/Fall is a major cause of serious injury or death. Beware of uneven or slippery work surfaces.

Exercise care when working in the vicinity of unprotected holes or excavations

OPERATION

GENERAL OPERATION

The machine is best suited to the compaction of bituminous and granular materials e.g. granular soils, gravels and sands or mixtures of both. Cohesive soils such as silt and clay are best compacted using the impact force produced by a vibrating rammer.

Where possible the site should be graded and levelled before commencing compaction.

Correct moisture content in soil is vital to proper compaction. Water acts as a lubricant to help slide soil particles together. Too little moisture means inadequate compaction; too much moisture leaves water-filled voids that weaken the soil's load bearing ability.

Use unleaded grade petrol and ensure that the fuel is free from contamination.

The vibratory motion provides a self propelling action. Position the handle at the opposite end of the machine to the vibrator.

Start the motor using the recoil starter. (If the motor is fitted with an on/off switch this must first be turned to ON before starting.)

For more information on starting and correct operating procedures of the motor, refer to the motor operation manual supplied with the unit.

Increase the motor speed to the maximum setting using the hand throttle lever, before commencing compacting.

The machine should be controlled by grasping the handle with both hands and applying restraint to control the forward motion.

Steer the machine by moving the handle sideways to the right or left.

ALWAYS maintain good footing so that you do not slip and loose control when starting or operating the machine

1. Prior to operation

1-1. Make sure that all dirt, mud, etc., are thoroughly removed from the unit prior to operation. Special effort should be given to the button face of the vibrating plate and those areas adjacent to the cooling air inlet of engine, carburetor, and air cleaner.

1-2. Check all bolts and screws for tightness and make sure all bolts and screws are securely tightened. Loose bolts and screws may cause damage to the Unit.

1-3. Check the V-belt for tightness. The normal slack should be approximately 10-15mm(1/2") when the belts are forcibly depressed in the middle position between the two sheaves.

If there is excess belt play, there could be a decrease in the impact force or erratic vibration, causing machine damage.

1-4. Check the engine oil level and if the engine oil level is low, it should be refilled. Use the proper motor oil as suggested in the table below. (Fig-1)

1-5. Remove the oil plug in the vibrator assembly and check the oil level. Make sure the compactor is level when checking. The oil level should be up to the oil plug. Every month or every 200 hours of operation, replace the oil.

! IMPORTANT:

Use the motor oil SAE
When changing the oil, the old oil can be drained by tipping the unit. The oil will drain easily while it is hot.

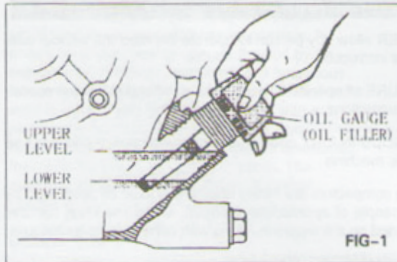

Season Temperature	Grade of Motor oil (higher than MS class)
Spring Summer or Autumn +120°F to +40°F	SAE 30
Winter +40°F to +15°F	SAE 20
Below +15°F	SAE 10W-30

1-6. A regular grade gasoline should be used in the engine.
When filling the fuel tank, make sure the fuel filter is used.

2. Caution

2-1. Be careful with the operating place and ventilation. Avoid operating the machine in a closed room, tunnel, or other badly ventilated places, since its exhaust contains deadly poisonous carbon monoxide. If the machine is employed unavoidable operated in such a place, discharge the exhaust out side the room by a suitable means.

2-2. Be careful with the hot members. Mufflers and other hot members are dangerous. Do not touch them with unprepared hand.

2-3. Observe with the following cautions when transporting. Clamp fuel tank cap securely, and turn the fuel valve OFF at the source during Drain gasoline from fuel tank before transporting over a long distance or on rough roads.

SPECIFICATIONS

Model	60H	60D
Engine	Air-cooled, 4-cycle, single cylinder	
Engine type	Petrol, Honda GX 160	Chinese Petrol Engine
Power kw (hp)	4.0(5.5)	
Weight kg (lbs)	64(140)	
Frequency (rpm)	5600	
Centrifugal Force (kN)	10.5	
Compaction Depth cm (in)	20(8)	
Travel Speed cm/s (in/s)	40(16)	
Efficiency m ² /hr (ft ² /hr)	450(4800)	
Plate Size cm (in)	50×36(20×14)	
Dimension cm (in)	108×40×80(43×16×31)	

BEARINGS

The following bearings are sealed:
Centrifugal clutch - grease lubricated
Vibrator - oil bath lubricated

FINISH

The machine is finished in gold equipment enamel, the handle in black baked enamel. Exposed metal surfaces are zinc electroplated for corrosion protection.

TROUBLESHOOTING

SYMPTOM	POSSIBLE CAUSES AND CORRECTION
Motor will not start.	- Check the ON/OFF switch to ensure that it is switched 'ON'. - Check the fuel supply. - If a Honda or Kama motor is fitted check the crankcase oil level as an oil sensor device is fitted to these motors which prevents starting and stops the motor when the oil level is low. - Ensure the spark plug ignition lead is connected - Check the carburettor jet and bowl to ensure they are clean.
Motor stops.	- Check the fuel supply. - Check that the fuel cock is turned on. - Check the condition of the air filter.
Petrol Motor lacks power.	- Check the condition of the air filter. - Check the condition of the spark plug.
Insufficient vibration	- Check for a slipping or a missing vee belt. - Check that the motor governed speed is 3,500 r/min.
Machine is not moving freely	- Check the underside of the plate for a build up of material

REPLACEMENT PARTS LIST

Major components and vibrator assembly parts list as followings.

- B. Remove spark plug, clean and adjust the spark plug gap to 0.6-0.7mm(0.02-0.03 in.). Fig-15
 C. drain the motor oil of the engine and replace with new specified oil. Fig-16

! NOTE: When the engine is new, the first oil change must be made after 20 hours of operation.

7-3.Monthly Service

Change the oil in the vibrator assembly.

7-4.Storage

When storing the compactor for long periods after operation.

- A. Thoroughly drain the fuel from the fuel tank fuel pipe and carburetor.
 B. Pour a few drops of motor oil into the cylinder by removing the spark plug.
 Rotate the engine several times by hand so that the cylinder interior is covered with oil.
 C. Clean the outer surface of the machine with an oil moistened cloth. Cover the unit and store in a humidity-free, dust-free area.

CARE AND PREVENTIVE MAINTENANCE

Check the oil level in the motor crankcase daily.

Check the vibrator oil level weekly.

Inspect the rubber anti vibration mounts for wear or deterioration.

Clean the underside of the plate regularly to prevent a build up of material.

SERVICE

Change the oil in the motor crankcase regularly to minimise wear.

Inspect, clean and/or replace the motor air cleaner regularly, particularly when operating in a dusty environment.

Inspect, clean and/or replace the spark plug regularly

Check all fasteners for tightness as the machine is subject to vibration.

Check vee belt tension, wear and that it is running true, adjust or replace as required.

Vibrator Oil Check

- 1.Place the plate compactor horizontally on a flat surface. Make sure the compactor is level when checking the oil in the vibrator assembly.
- 2.Check vibrator oil level by removing the plug (vibrator oil gauge)as shown in Fig-17.
- 3.When changing the vibrator oil, remove the drain plug(Fig-17), and simply tip the compactor to drain the oil.Note that the oil will drain more easilywhile it is hot.

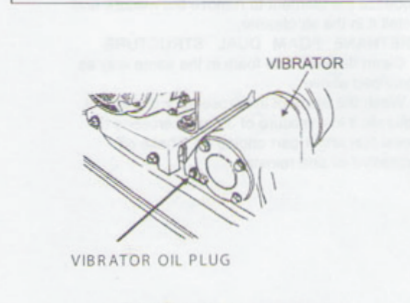
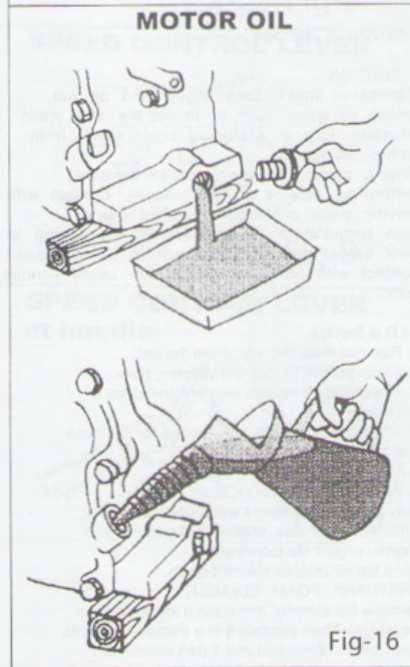
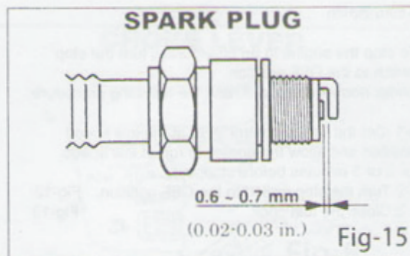

- 2-4.Stop engine without fail before replenishing fuel tank.
 Never replenish gasoline while the engine is running or remains hot otherwise spilled or evaporated fuel is liable to catch fire from engine sparks or muffler heat.
 Wipe off spilled fuel, if any, before starting engine. Be careful not to spill fuel.
 2-5.Keep inflammables away from the vicinity of the exhaust port.
 Be careful with gasoline match, straw and other inflammables, since the exhaust port is subjected to a high temperature.

3.Starting

Gasoline Engine

- 3-1 .Turn the STOP SWITCH clock-wise to the position "I"(ON). Fig-3
- 3-2.Open the fuel cock. Fig-4
- 3-3.Set the speed control lever 1/3 to 1/2 of the way towards the high speed position. Fig-5
- 3-4.Close the choke lever.
 If the engine is warm or the ambient temperature is high, open the choke lever half-way, or keep it fully open.
 If the engine is cold or the ambient temperature is low, close the choke lever fully. Fig-6
- 3-5. Pull the starter handle slowly until resistance is felt. This is the "compression" point. Return the handle to its original position and pull swiftly.
 Do not pull out the rope all the way.
 After starting the engine, allow the starter handle to return to its original position while still holding the handle.

Diesel Engine

- 3-6.Turn the throttle lever to START position(open by about 30 degrees) Fig-5-D

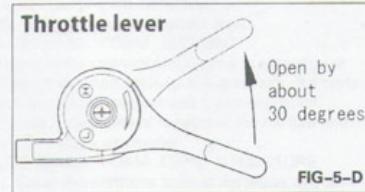

3-7.Operate Starter

In case of recoil starter
 By pulling the starter knob slowly, you will reach such point where resistance become strong(compression point).by pulling it further, you will Find a point where resistance is reduced. Return the knob but slowly return it original Fig-7-D

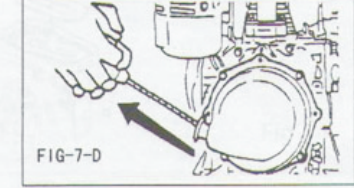
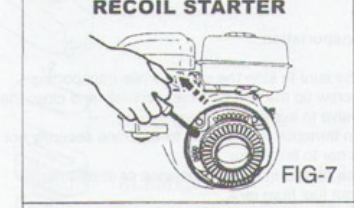
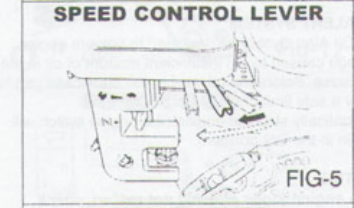
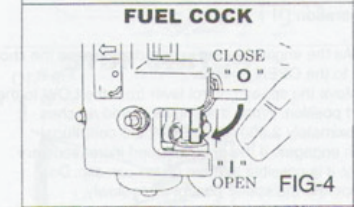
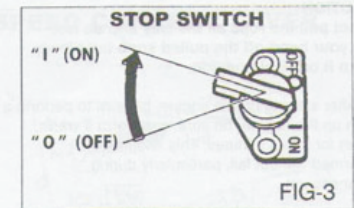

! CAUTION

Do not pull the rope all the way and do not take your hand off the pulled knob but slowly return it original position.

3-8. After starting up the engine, be sure to perform a warm up the engine, be sure to perform a warm up run for 2 to 3 minutes. This should be performed without fail, particularly during winter season.

4. Operation

4-1 .As the engine warms up, gradually move the choke lever to the OPEN position Fig-8

4-2. Move the speed control lever from the LOW to the HIGH position. When the engine speed reaches approximately 2,300-2,600 PRM, the centrifugal clutch engages. If the engine speed increased very slowly, it is possible that the clutch can slip. Do not operate the speed control lever slowly. Fig-9,10

OIL ALERT SYSTEM

The Oil Alert System is designed to prevent engine damage caused by an insufficient amount of oil in the crankcase. Before the oil level in the crankcase can fall below a safe limit, the Oil Alert System will automatically stop the engine (the engine switch will remain in the ON position).

! NOTICE

If the engine stops and will not restart, check the engine oil level.

4-3. When compacting asphalt, it is advisable to paint the bottom face of the vibrating plate with diesel fuel.

This will assist in preventing the plate from sticking to the asphalt.

4-4. When shutting off the vibrator, turn the speed control lever from the HIGH to LOW position. Do not move the speed control lever slowly.

5. Transportation

5-1 .Be sure to stop the engine while transporting.

5-2. Screw up the fuel tank cap securely and close the fuel valve to avoid fuel leaking.

5-3. In transportation by car, fix machine securely not to move nor to fall down.

In case of driving for long distance or at off-road, tank out fuel from tank.

CHOKE LEVER



Fig-8

SPEED CONTROL LEVER

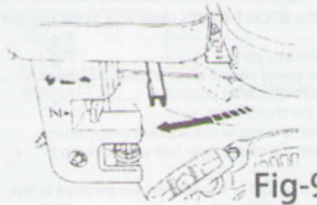

Fig-9

SPEED CONTROL LEVER at handle

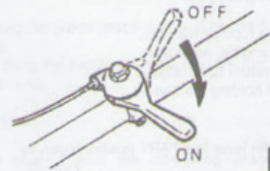

Fig-10

6. Shutdown

To stop the engine in an emergency, turn the stop switch to the OFF position.

Under normal conditions, use the following procedure:

6-1 .Set the speed control lever at the low speed position and allow the engine to run at low speed for 2 or 3 minutes before stopping.

6-2. Turn the stop switch to the OFF position. Fig-12

6-3. Close the fuel cock. Fig-13

7. Service & storage

! CAUTION

Flammable liquid: Stop engine and do not smoke or allow work in immediate area when refueling. Fire or explosion could result from flames or sparks.

Moving parts: Shutdown engine before performing service or maintenance. Contact with moving parts can cause serious injury.

High temperature: Allow machine and engine to cool before performing service or maintenance. Contact with hot components can cause serious burn.

7-1. Daily Service

A. Remove mud, dirt, etc., from the unit.

B. Clean bottom face of the vibrating plate.

C. Check the air cleaner element and clean if necessary

D. Check all nuts, bolts, and screws for tightness and retighten as necessary.

7-2. Weekly Service

A. AIR CLEANER SERVICE

Fig-14

Dirty air cleaner element will cause starting difficulty, power loss, engine malfunctions, and shorten engine life extremely.

Keep the air cleaner element clean.

URETHANE FOAM ELEMENT

Remove the element and wash it in kerosene or diesel fuel. Then saturate it in a mixture of 3 parts kerosene or diesel fuel and 1 part engine oil. Squeeze the element to remove the mixture and install it in the air cleaner.

URETHANE FOAM DUAL STRUCTURE

1. Clean the urethane foam in the same way as described above.

2. Wash the element in kerosene or diesel fuel. Saturate it in a mixture of 3 parts kerosene or diesel fuel and 1 part engine oil. Shake off excessive oil and reinstall.

SPEED CONTROL LEVER

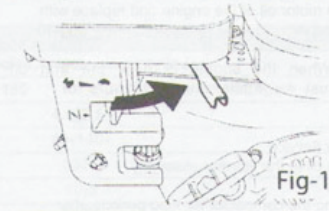

Fig-11

STOP SWITCH

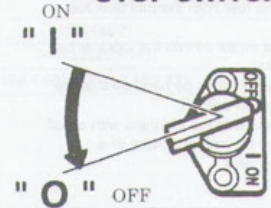

Fig-12

FUEL COCK

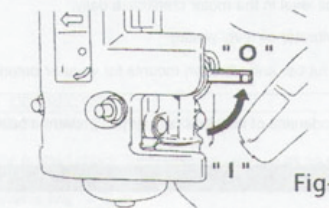

Fig-13

AIR CLEANER

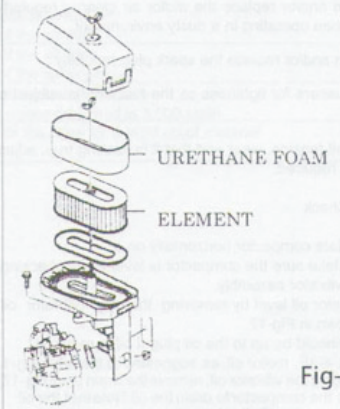

Fig-14