

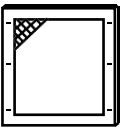

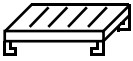

# Assembly Instructions

# CYLINDER STORAGE CABINET MODEL: CCH004

A	B	C	D	E	F
					
Back panel	Base	Door	Side panel	Shelf	Top panel
1 PC	1 PC	1 PC	2 PCS	1 PC	1 PC

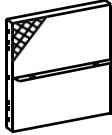
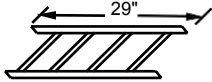
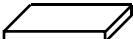
G	H
 1/4" x 3/4"	
Bolt and nut	Washer
26 Pairs	26 PCS

\*Caution: Two person assembly is recommended.

1. In an open assembly area free of obstructions, place the base (B) upright as shown. Assemble each side panel (D) by hand-tightening the bolts, washers, and nuts provided (G & H). Side panels should be mounted such that the flat part of the shelf support rail will face upward.

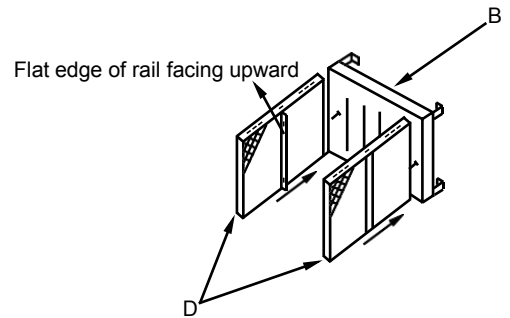

2. Assemble the top panel (F) to the side panels (D). Hand-tighten the bolts, washers, and nuts provided (G & H). Ensure the unit is square and firmly tighten the bolts connecting the side panels to the top panel. Set unit upright.

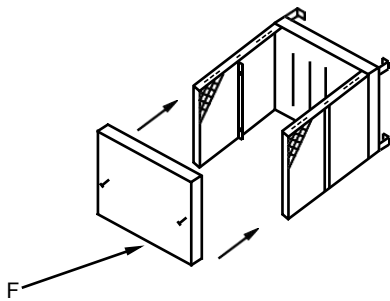

3. Connect the back panel (A) to side panels (D) using bolts, washers, and nuts provided (G & H). Ensure the unit remains square and firmly tighten the nuts. Note: out of square assembly will prevent the door from closing properly.

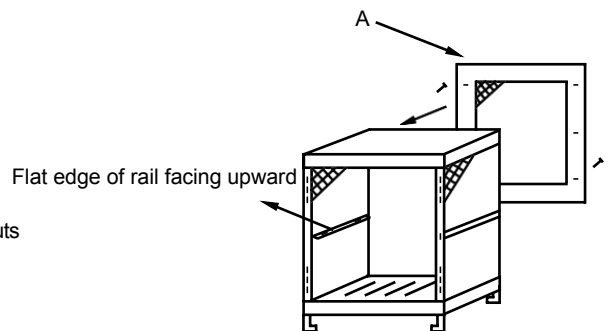

4. Attach the door (C) to the assembly using bolts, washers, and nuts provided (G & H).  
Note: that the hinges are configured for a left-hand swing, but mounting hardware can be removed and reversed to a right-hand swing if desired. Hand-tighten nuts, adjust the door's position such that an even gap is maintained on all sides. Then firmly tighten nuts.

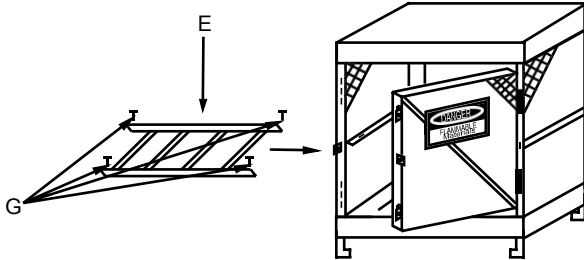
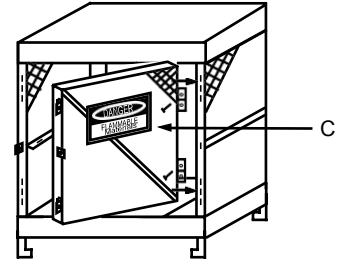

5. Insert the shelf (E) and bolt it to the shelf support rail using bolts, washers, and nuts provided (G & H).

6. Finished.

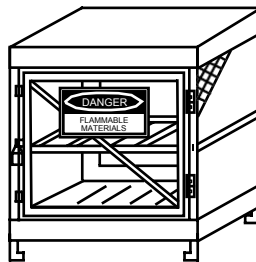

Stock Number	Finish	Dimension(In.) W × D × H	Capacity
CCH004	Powder Coated	31 × 30 × 35	4 Horizontal