

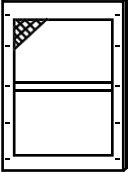

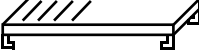

Assembly Instruction

CYLINDER STORAGE CABINET MODEL: CCH8V9

					
Back panel	Base	Chain	Door	Left side panel	Mid-panel
2 PCS	1 PC	2 PCS	2 PCS	1 PC	1 PC
					
Right side panel	Shelf	Top cover	Bolt and nut	Washer	
1 PC	3 PCS	1 PC	53 Pairs	53 PCS	

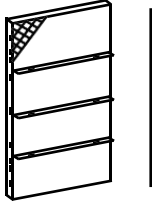
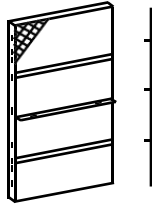
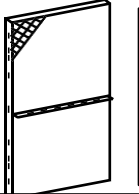
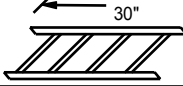
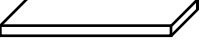
*Caution: Two person assembly is recommended.

1. In an open assembly area free of obstructions, place the base (B) upright as shown. Assemble each side panel (E & G) and mid-panel (F) by hand-tightening the bolts, washers and nuts provided (J & K). Panels should be mounted such that the flat part of chain/shelf support rail will face upward.

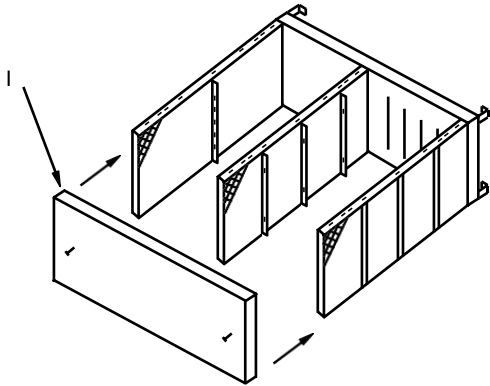
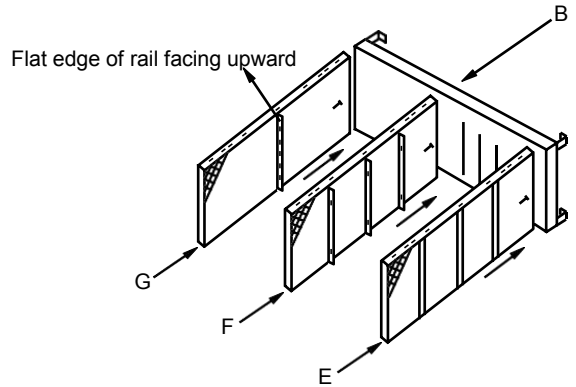

2. Assemble the top panel (I) to the side panels (E & G) and mid-panel (F). Hand-tighten the bolts, washers, and nuts provided (J & K). Ensure the unit is square and firmly tighten the bolts connecting the side and mid panels to the base. Tighten the bolts connecting the side and mid panels to the top panel. Set unit upright.

3. Connect the back panels (A) to side panels (E & G) and mid-panel (F) using bolts, washers, and nuts provided (J & K). Ensure the unit remains square and firmly tighten the nuts. Note: out of square assembly will prevent the door from closing properly.

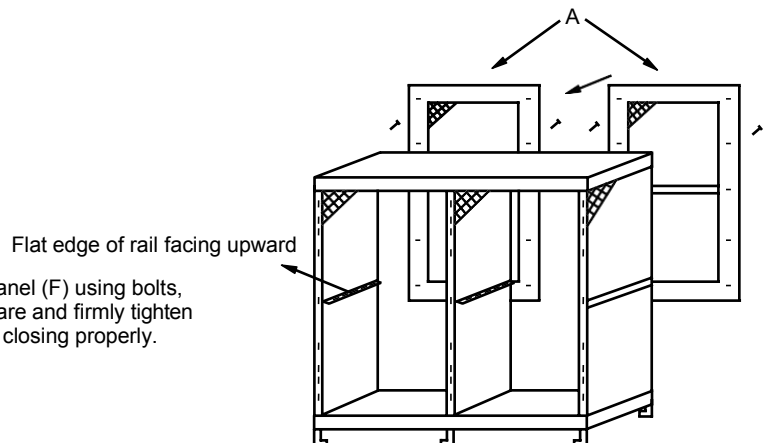

Assembly Instruction

CYLINDER CABINET MODEL: CCH8V9

4. Attach the doors (D) to the assembly using bolts, washers, and nuts provided (J & K).
Note: that the hinges are configured for a left-hand swing, but mounting hardware can be removed and reversed to a right-hand swing if desired. Hand-tighten nuts, adjust the door's position such that an even gap is maintained on all sides. Then firmly tighten nuts.

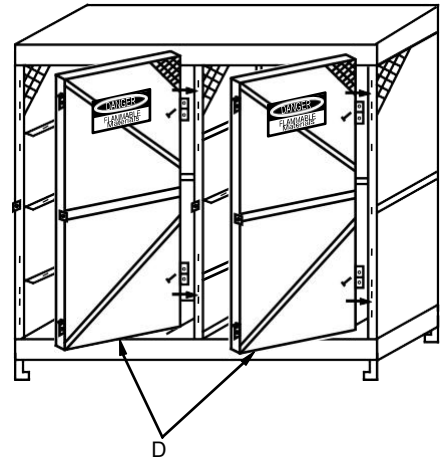

5. Insert the chains (C), shelves (H) and then bolt the shelves to the shelf support rail using bolts, washers, and nuts provided (J & K), buckle the chains to the chain support rail.

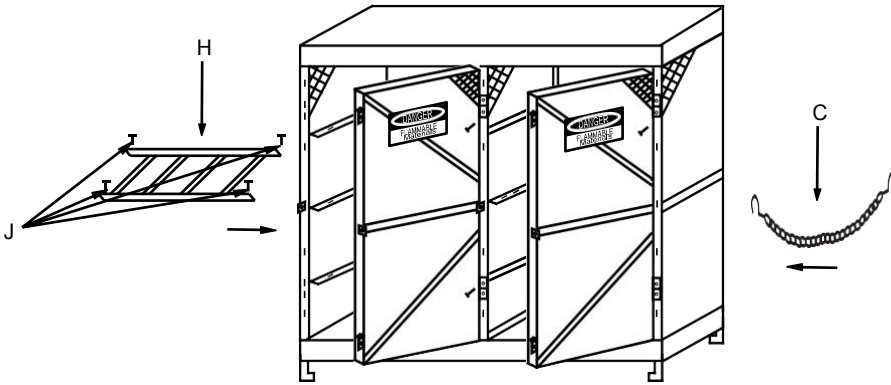

6. Finished.

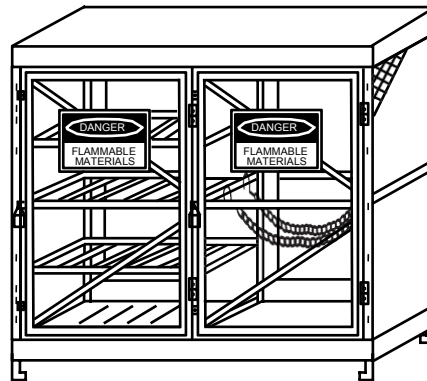

Stock Number	Finish	Dimension(In.) W × D × H	Capacity
CCH8V9	Powder Coated	60 × 30 × 65	8 Horizontal & 9 Vertical