

# DOWELL Fixed TV Wall Mount Installation Instruction

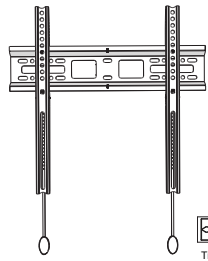

Model: DWD908F  
 Fit For Screen Size: 32"-55"  
 Max Loading Weight: 50kg(110lbs)  
 Distance To Wall: 30mm  
 VESA: 100x100/200x100/200x200/300x200/  
 300x300/400x200/400x300/400x400mm



## Wall plate installation accessories



## TV installation accessories

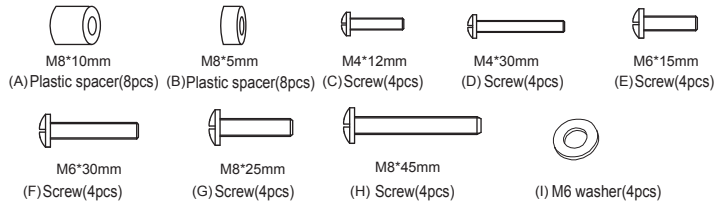

## Tools Needed



### Step-1: Install the wall plate.

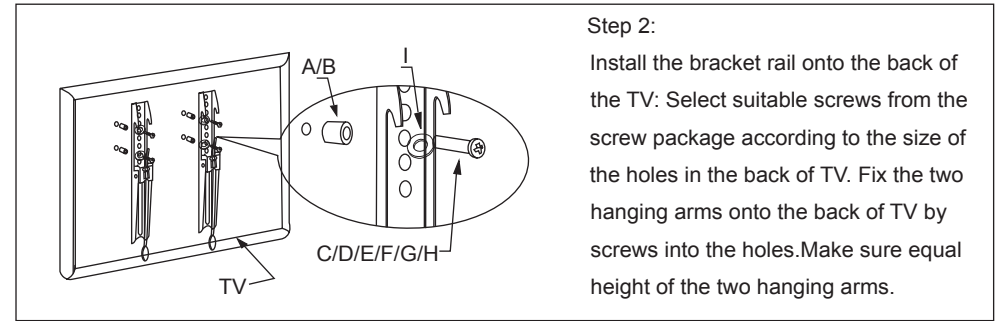
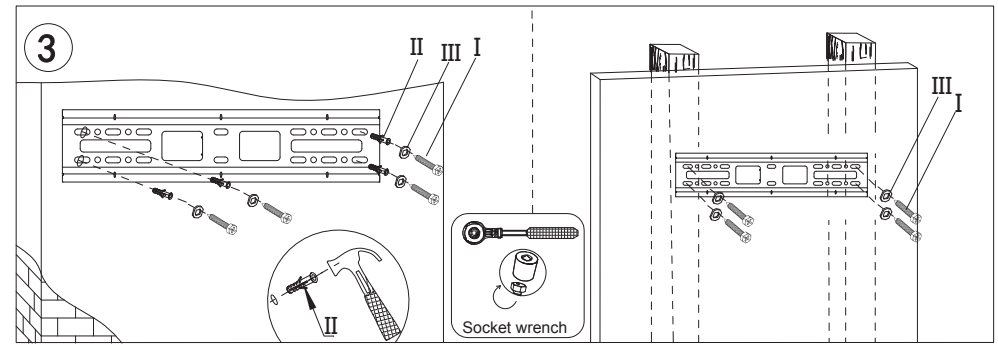
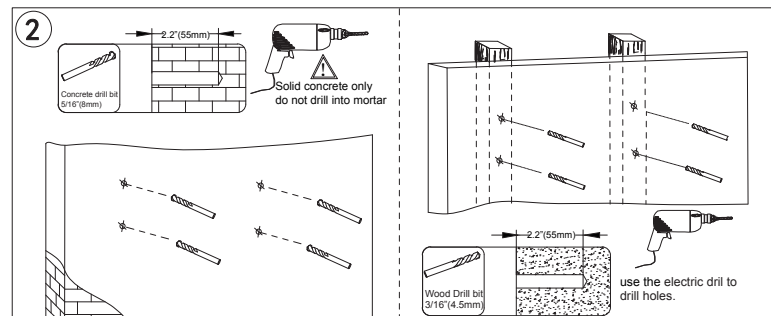
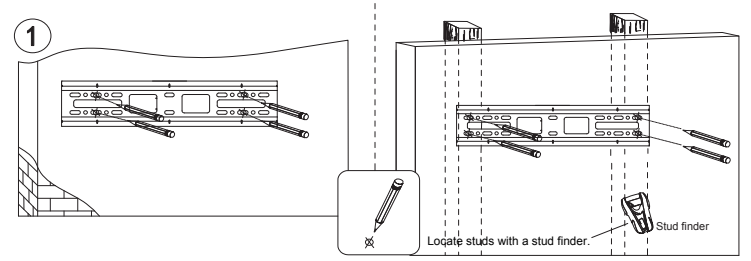

### Step 2:

Install the bracket rail onto the back of the TV: Select suitable screws from the screw package according to the size of the holes in the back of TV. Fix the two hanging arms onto the back of TV by screws into the holes. Make sure equal height of the two hanging arms.

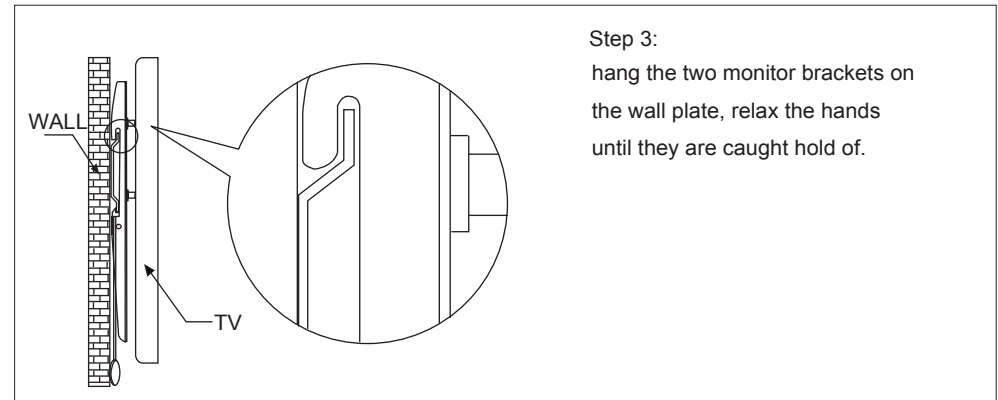

### Step 3:

hang the two monitor brackets on the wall plate, relax the hands until they are caught hold of.

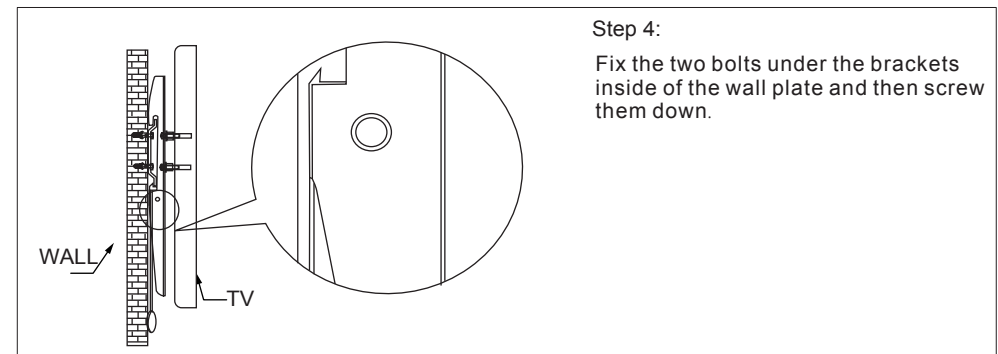

### Step 4:

Fix the two bolts under the brackets inside of the wall plate and then screw them down.