

ONE、 Foreword

1、 Summarization

Thanks for using our machine, It's a safe ,applied and efficient sealing and shrinking 2 in 1 packaging machine .

2、 Matters need attentions

- A. Pls read this manual before use the machine;
- B. Pls take the cautions and machine commond sense in mind before use the machine;
- C. Pls Keep this manual in order to reference;
- D. Give this manual to the end user;
- E. We reserve the right to make technical modification on this machine and manual in order to improve and perfect machine performance ;
- F. Pls contact us if you have any good suggestion for this machine and manual;

3、 safety cautions

- A. The breaker and wires applied must correspond to the capacity of the power supply of machine; Otherwise , damage occurs to the parts or wiring if the smaller capacity breaker or the smaller diameter wires are applied.
- B. To guarrantee the liquid would not leak out when packing liquid product ,if not ,damage would be made to the machine or the operator would possibly get the electric shock
- C. Don't use the machine in a very moist and humid environment or a place which full of a lot of vapor;

- D. Don't use the machine in the place which full of dust
- E. The sealing blade , asbestos slot and the heating tubo are of high temperature after a long time running ,don't touch by hand;
- F. Don't put any metal parts under the sealing blade when sealing in order to avoid damaging to sealing blade;
- G. The sealing time should be of 0.8 to 1.5 second in general ,the sealing blade would be damaged if the sealing time was set too long.
- H. The shrinking temperature should be set between 200°C to 300°C,The sealing blade would be damaged or a bad packaging effect occurs if the shrinking temperature is too high.
- I. The sealing blade , teflon belt and neoprene rubber would be worn after a period of time using ,so please prepare some damageable parts , examine and repair the machine periodically.
- J. Pls cut off the electricity before change the parts .and change the parts in order .

4、Features of the machine

- A. This machine is widely used for the packaging application of these industries :food ,toy ,hardware ,cosmetic ,medicine ,daily commodity ,books ,bamboo product ,wooden product and electric appliance;
- B. Sealing and shrinking 2 in 1 machine occupying small space and easy to operate;
- C. Applied to variety of shrink film such as PVC,POF etc;
- D. The sealing blade is made of alloy ,stick-proof and high temperature-proof without carbonization and smoking when packing ,it's prove the sealing part

steady ,The sealing time is easy to adjust according to the thickness of the film ;

E. Stainless steel heating tube with Heat Sink on the surface that heat up fast and long life-span of usage;

F. Seal and shrink in one time ,safe , reliable and easy to operate ,the part sealed on the film is firm and looks well;

G. this machine can work continuously for a long time。

TWO、 Machine dimension and wooden carton dimension

1、 Machine dimension

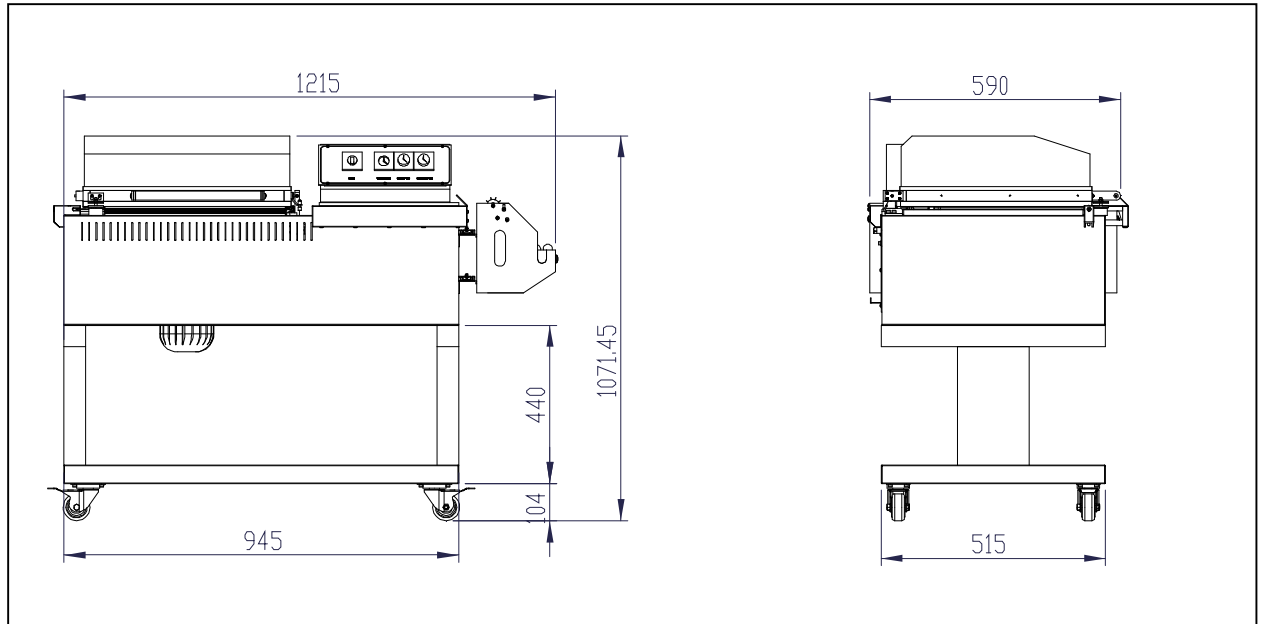

FM-4030 dimension

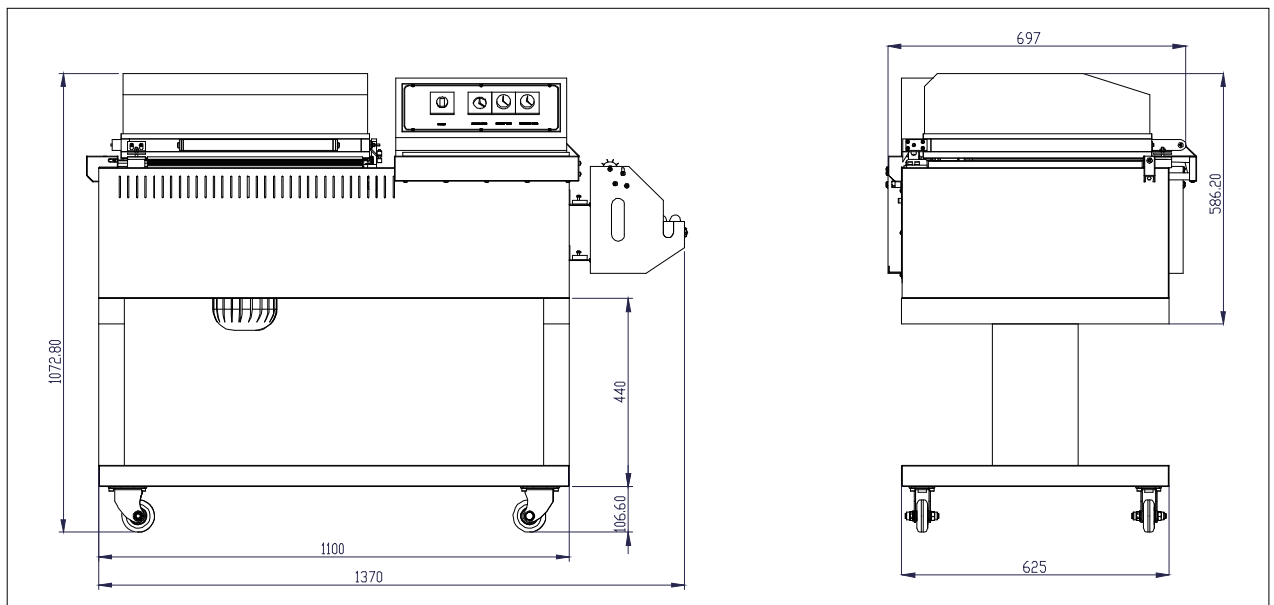

FM-5540 dimension

2、Wooden carton dimension

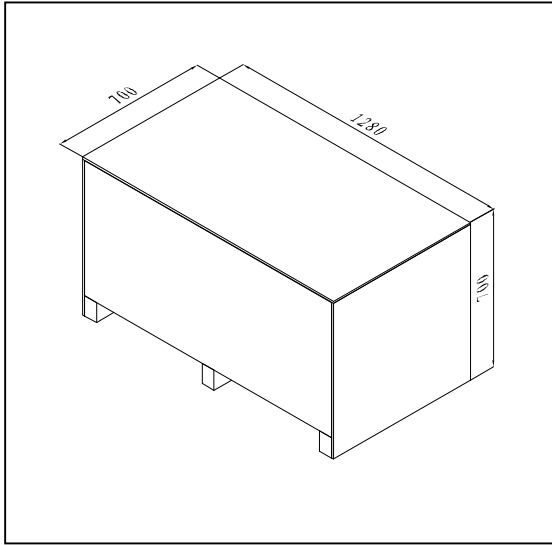

FM-4030 carton dimension

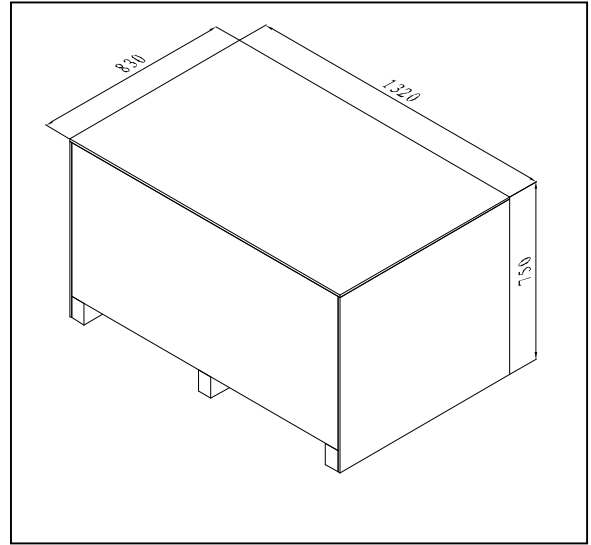

FM-5540 Carton dimension

THREE、 components of the panel

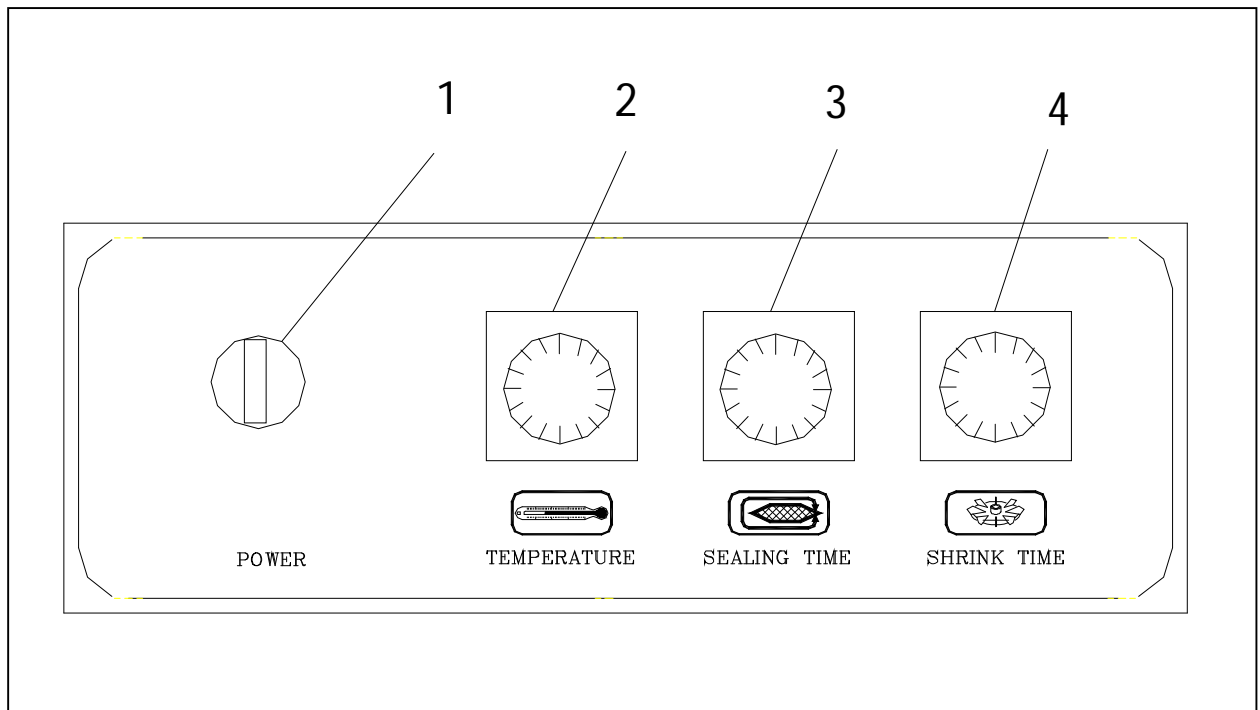

- A. Power: Turn on or off the power of machine ;
- B. temperature: set the temperature of heating system;
- C. sealing time: set the sealing time of blade;
- D. shrink time: set the shrink time of shrink system;

FOUR、 Machine parts illuminate drawing

1、 final assembly drawing

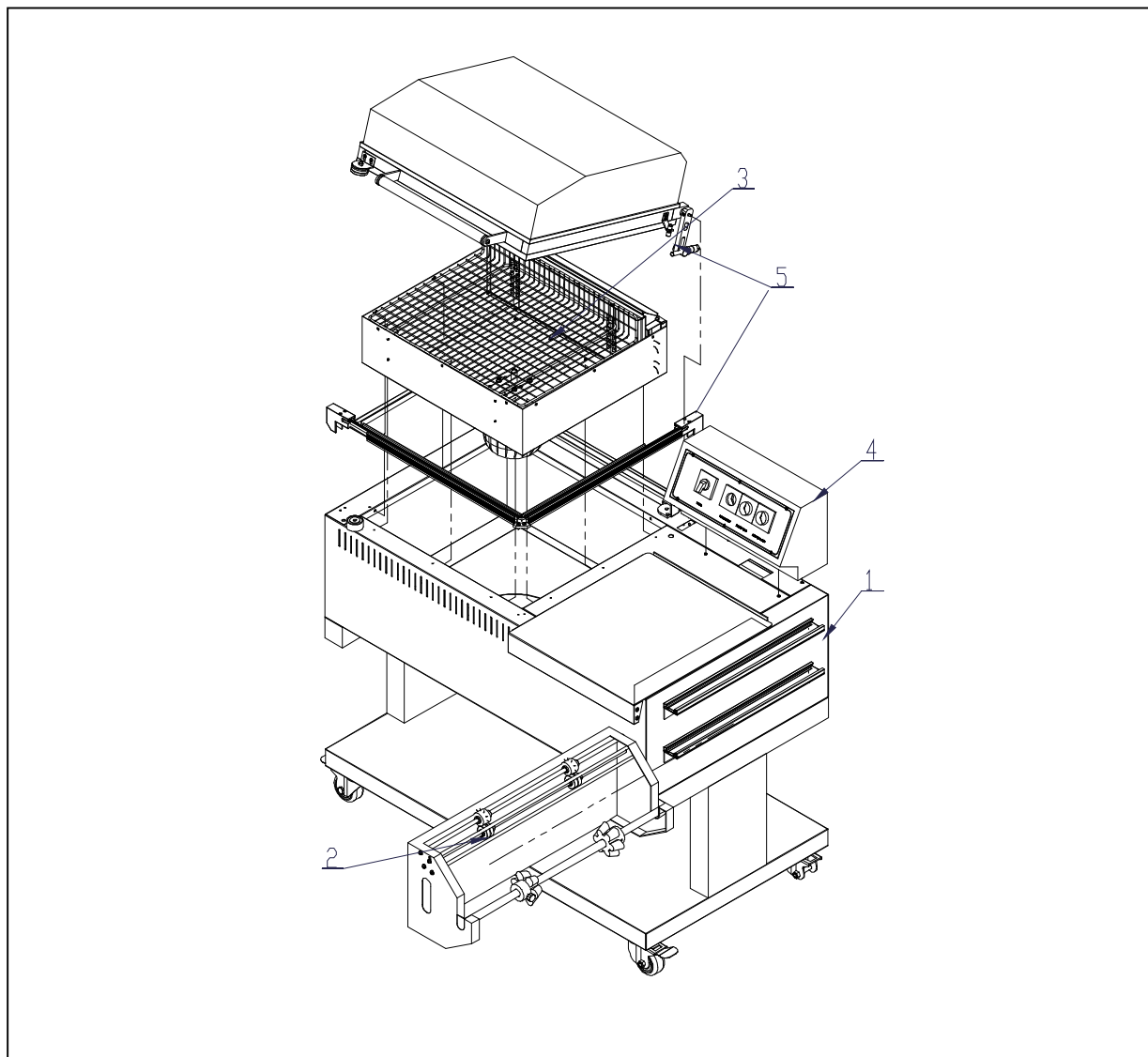

No.	Name	Qty
1	frame	1
2	Film feeding system	1
3	Srink system	1
4	Electric control system	1
5	Sealing system	1

2、Distributor plate illuminate drawing

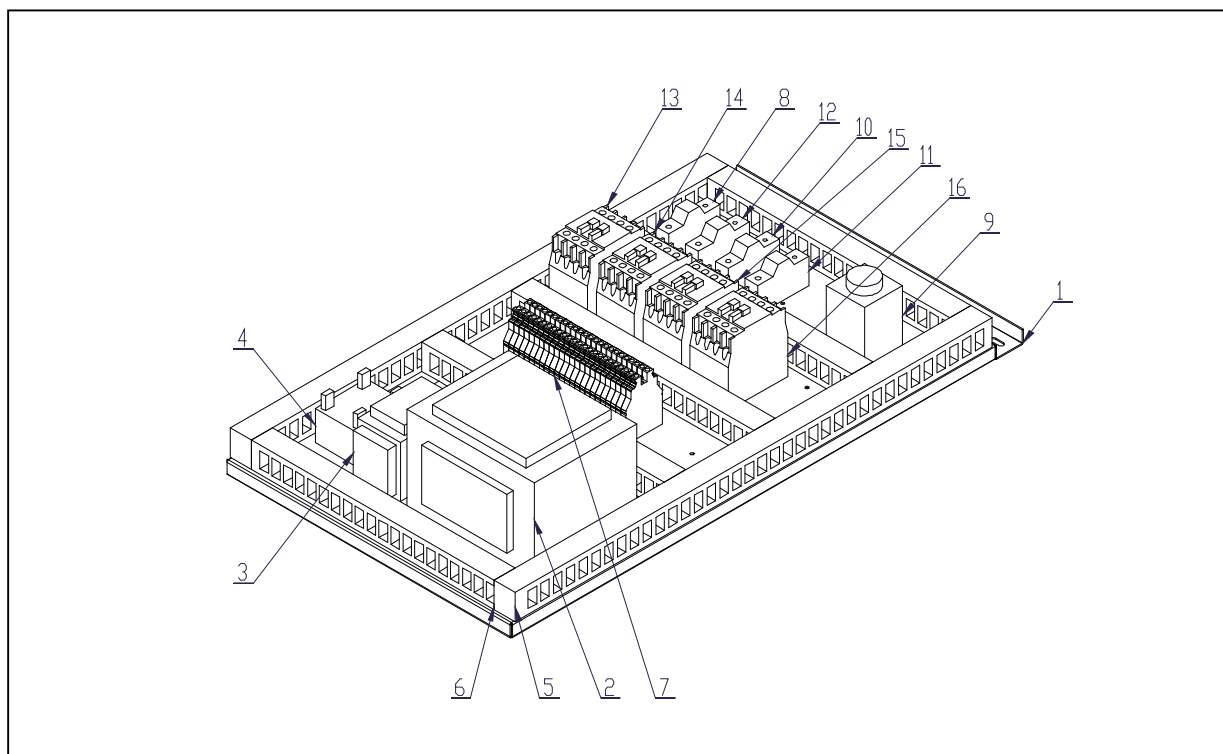

No.	Item	Name	Qty
1		Distributor plate	1
2	T2	Sealing blade Transformer	1
3	T1	Electromagnetic Transformer	1
4	V1	rectifier bridge	1
5		wiring duct	1
6		wiring duct 2	1
7	X	Terminal block	1
8	QF1	Heating tube circulate breaker	1
9	KT2	Delay relay	1
10	QF2	Electronagnetic circulate breaker	1
11	QF3	Sealing circulate breaker	1
12	QF4	Blowing circulate breaker	1
13	KM1	Electromagnetic circulate contactor	1
14	KM2	Blowing circulate contactor	1
15	KM3	Heating tube circulate contactor	1
16	KM4	Sealing circulate contactor	1

3、blowing system

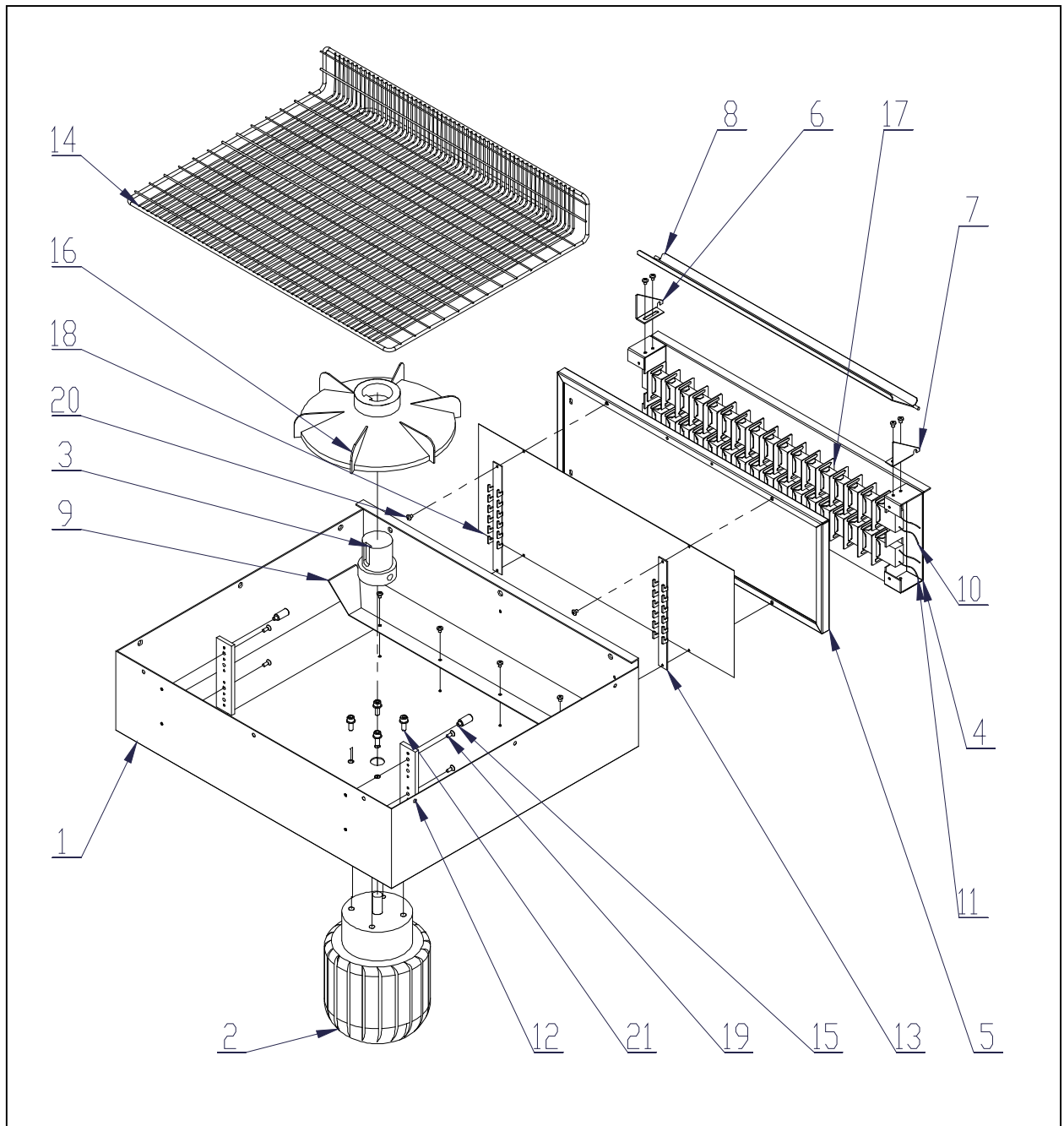

No.	Item	Name	Qty
1	1-18B	Install box of fan	1
2		Blowing motor	1
3	2-16J	Shaft sleeve of blowing motor	1
4	1-25B	assembling board for heating tube	1
5	1-27B	Front heat insulation board	1
6	1-22B	left support board for upper frame	1
7	1-22B	Right support board for upper frame	1
8	1-24B	The open and close board	1
9	1-26B	Wind guide board	1
10	1-35B	thermocouple	1
11	1-35A	Heating tube	2
12	1-29B	support board for mesh worktable	2
13	1-28B	Pothook for mesh worktable	2
14	1-34B	Mesh worktable	1
15	2-37J	Bolt for support board	2
16		fan	1
17	1-36B	Heat Sink	34
18		Heat insulation board	1
19		bol t	4
20		GB-CROSS-SCREWS-TYPE1 M4X5-5	12
21		Socket head screw M6X16+ gasket 6	4

4、 Reel holder system drawing

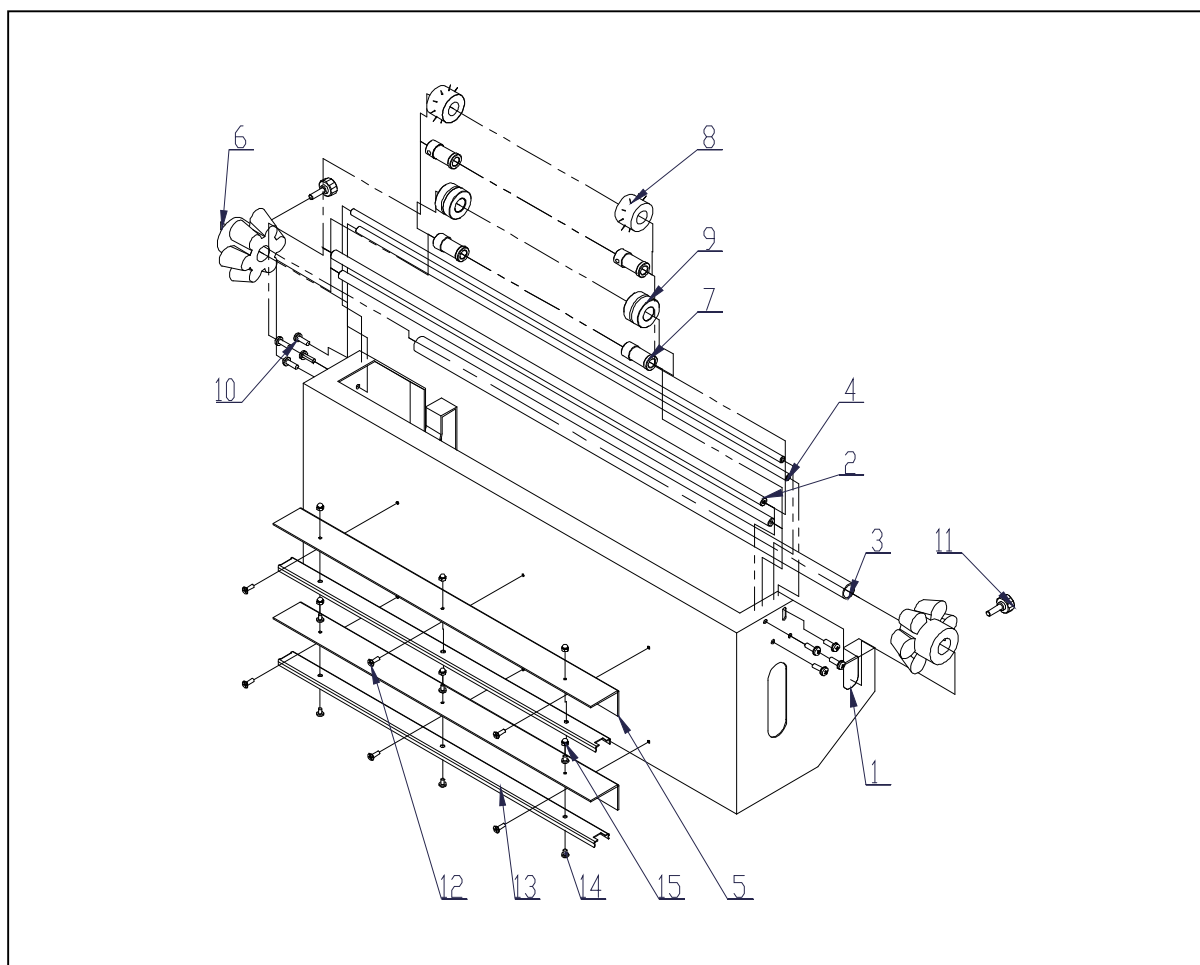

No.	Name	Qty
1	Reel holder	1
2	Shaft of perforator	2
3	Wheel	1
4	Shaft for guide film	2
5	Installation shelf for guild rail	2
6	Fixer	2
7	Cover of the perforator wheel	4
8	Pin wheel of the perforator	2
9	grooved wheel	2
10	cross recessed round head screw M5X16	8
11	Fixer bolt	2
12	bolt	6
13	Upper board of moveable rail	2
14	GB-CROSSS-SCREWTYPE1M4X6-6	6

FIVE、 technical parameters table

model	FM-4030	FM-5540
Power supply	1 phase 220V 50Hz 1phase 110V 60Hz	1 phase 220V 50Hz 1 phase 110V 60Hz
power	3.8kw	4.0kw
Max sealing size	L400*W300	L550*W400
dimension	L1215*W590*H1020	L1370*W697*H1073
weight	100kg	125kg

SIX、 Installation

- A. Remove the upper cover board of carton and then remove the sour side boards;
- B. lift and place the machine on the flat ground ;
- C. Unpack the protective film which wrapping on the machine and parts;
- D. Install the four wheels at the bottom of the base plate in turn and make sure the ones with brake installed in the front;
- E. Install the two stands on the left and right side of the base plate in turn ,fastening the screws;
- F. Put the main body of the machine on the stands (Notice :make the four iron bolt on the main body of the machine exactly into the four holes on the stands);
- G. The moveable rail on the reel holder corresponds to the moveable rail on the right side of the machine body ,Adjusting and making the reel holder in (Notice: some users would like to hang the reel holder up on the machine ,if so please screw off the screws on the right side of the machine body ,hanging the reel holder up and fastening the screws.);
- H. Be sure that the power supply used corresponds to the nameplate which shown at the rear of the machine 。

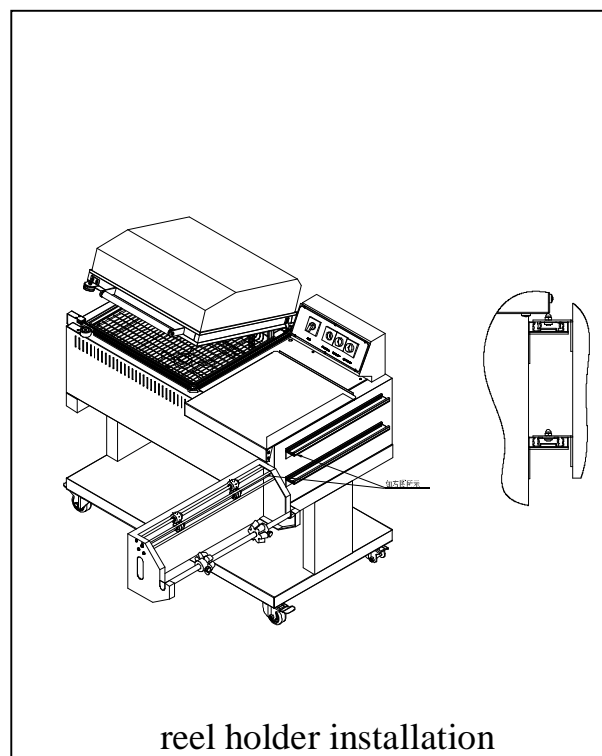
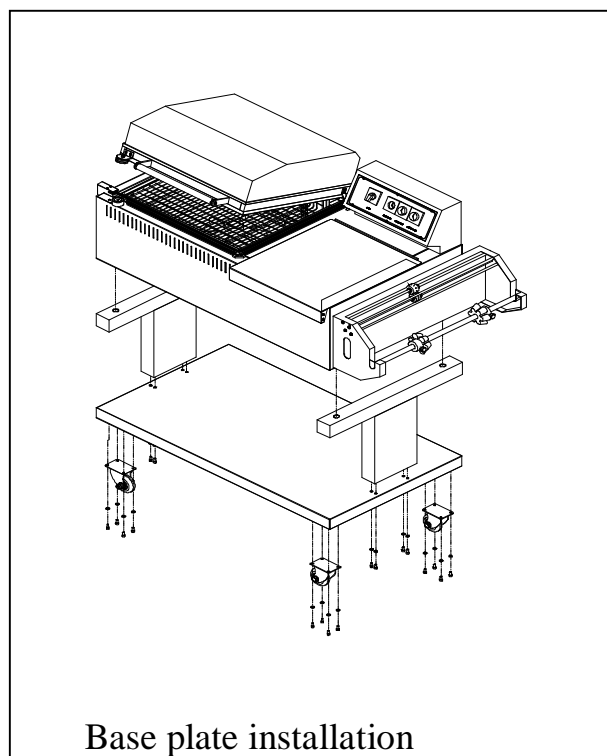

SEVEN、 Operation method

- A. Turn the power on ,adjusting the shrinking temperature according to the variety and thickness of the shrink film,200° C to 300°C in general;
- B. Set the sealing time according to the thickness and variety of the shrink film,0.8 to 1.5 second in general (The best is to set the sealing time apropos to make the sealing part steady and good effect, the time set too long would result in the blade ,blade slot and neoprene rubber are easy broken, set too short would effect the sealing effect and even cann't cut absolutely);
- C. Usually ,set the sealing time a little longer when just turn power on due to there is no any accumulation of heat in the blade ,Set the sealing time a little shorter than beginning due to the accumulation of the heat in the blade.;
- D. drill the shaft of the reel through the film reel ,move the fixer to the center of the reel and fasten the screws;
- E. If hanging reel holder is the choice, put the film reel between the two rollers directly and posit the two support and get them fastened. ;
- F. Put the film reel with a shaft on reel holder ,make the open side of the film toward to the operator.;
- G. drill the film through the perforator ,separate the two layers ,get it surround the working table;
- H. Adjust the height of the mesh ,parallelizing the center line of the product to be sealed with the sealing blade;
- I. Stretch the film to the sealing area and sealing the film only as first sealing;

- J. Place the product on the working table ,Let it covered by the upper sheet of the film ,stretching the film and the product to the sealing area in the left ;
- K. Keep a distance of the product to the sealing blade as 1/2 height of product in order to have enough film for shrinking;
- L. The indicator light of temperature regulator which on the control panel will turn to red when the practical temperature reach the set value ,if so ,press down the chamber hood then the sealing procedure are automatically finished ,then the blowing shrinking running automatically after 1 second's delay.
- M. The delay equipment is installed in the machine and had been set the general parameter's value well ,if it needs to be reset ,please ask the professional technician to do it or consult the supplier;
- N. The chamber hood spring up automatically after the blowing;

EIGHT、 Machine maintenance

- A. Clean the working table and shrinking chamber after the daily use;
- B. Clean the sealing blade periodically, Notice: Clean the sealing blade by a piece of dry cotton cloth with the release agent ,Don't use any metal scratch the sealing blade;
- C. The moveable parts such as transmitting chains ,bearing base needs to be oiled with lubricant often;
- D. The sealing blade , teflon belt and Neoprene rubber must be kept well ,if any of them is worn or damaged ,replace it with new one soon;
- E. Turn the power off before repairing ,let professional to do it;
- F. The procedures of replacing the sealing blade
 1. Unfasten the hexangular screws on the blade clamp ,take the worn sealing blade out;
 2. Then Put one end of the new sealing blade into the slot of the blade clamp ,push the screw on the top of the blade clamp by a tough tool in order to make it unmovable ,then tighten the hexangular screws for fixing the sealing blade;
 3. put the sealing blade into the ceramic blade slot lightly ,then put the other end of sealing blade into the slot of the other blade clamp;
 4. push the screw on the top of the blade clamp by a tough tool in order to make it unmovable ,then tighten the hexangular screws for fixing the sealing blade;

5. End.

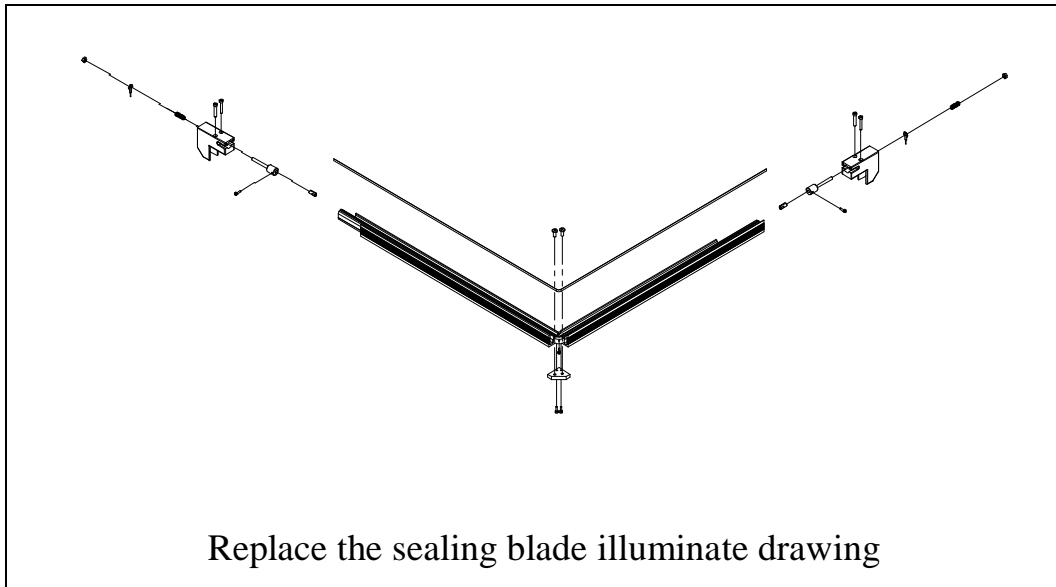

NINE. Circuit diagram

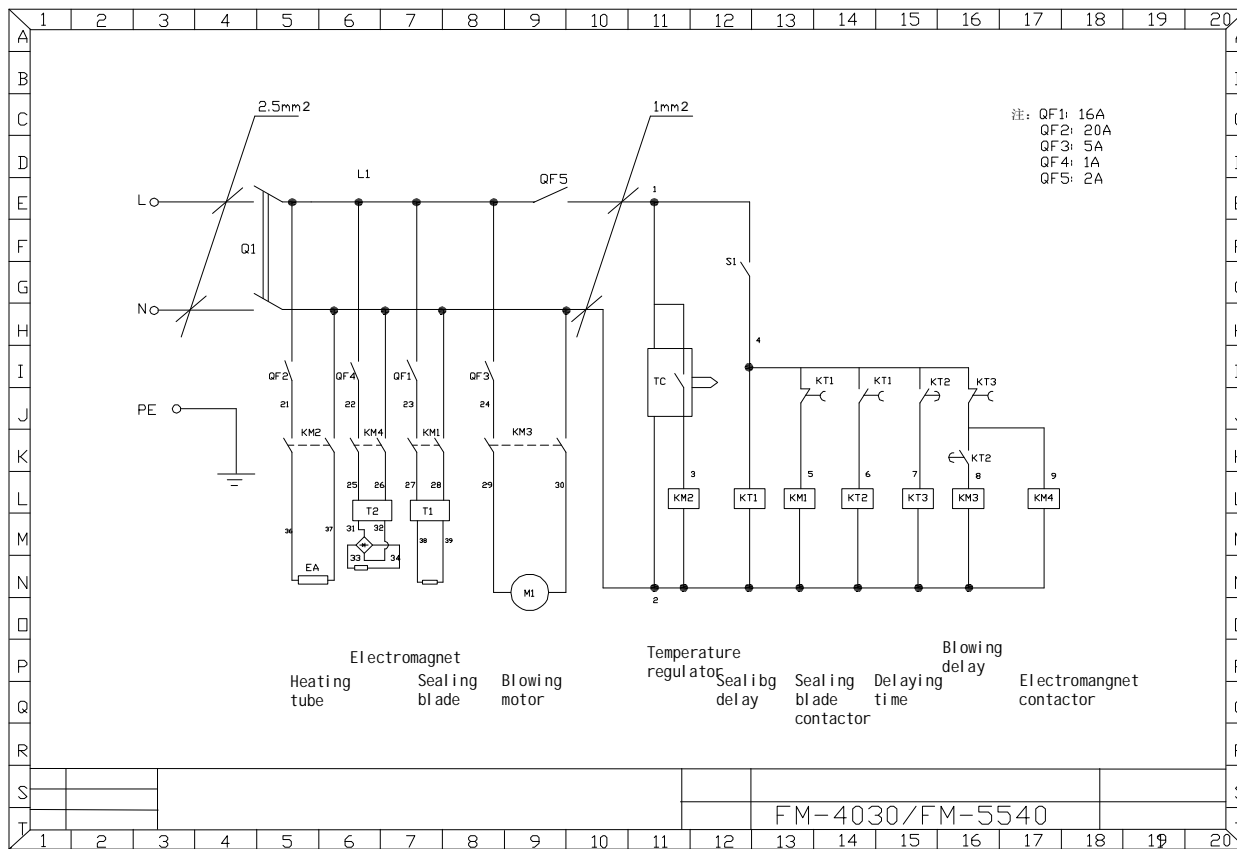

TEN. Trouble shooting

Fault and failure	Cause	clearing of fault
There isn't any heat on the sealing blade	The breaker tripped	Check the circuit and turn on the breaker
	The sealing blade is damaged	Replace the sealing blade
	Transformer damaged	Test the output of the transformer during the course of sealing ,replace the transformer with a new one if it's output doesn't reach 54V
The sealing blade can be heated ,but the film can not be cut off	Partial damage to the sealing blade	Replace the sealing blade with a new one if breach found on it
	Something unknown attached on the sealing blade	Clean the sealing blade by a piece of cry cotton and the release agent
	The teflon belt damaged	Replace the teflon belt with a new one
	The neoprene rubber damaged	Replace the neoprene rubber with a new one if it's surface is not smooth
	The screws for fixing the ceramic slot of the sealing blade found to be unfastened ,leading to the lean or incline of the ceramic slot of the sealing blade	Adjust the ceramic slot and fasten the screws
The blowing motor works but the shrinking effect is not good	The shrinking temperature is too low	Increase the shrinking temperature
	The blowing and shrinking time is too short	Increase the blowing and shrinking time
The chamber hood fall to it's right place but the machine can't seal and cut the film	The inching switch which check and examine whether the chamber hood has fallen to the right place was of failure or not to be adjusted well	Make the inching switch working when the chamber hood falls to the right place or replace the jiggle switch with a new one once it was damaged.

ELEVEN、 Packing list

No.	Name	Spec.	Qty
1	machine		1set
2	breaker	C32N1P16A	1pc
3	breaker	C32N1P2A	1pc
4	manual		1ps
5	Teflon tape		1set
6	Sealing blade		1set
7	Hexangular spanner	M6	1pc
8	Hexangular spanner	M4	1pc