



T18

Program-controlled Paper Cutter

OPERATING INSTRUCTION



Thank you for choosing this kind of Hydraulic Paper Cutting Machine which series are produced by our company. We will provide the perfect quality of this machine and the best service after sale. The series of Hydraulic Paper Cutting Machine is designed and developed through summarized experience from domestic and abroad asset. It is integrated mechanical, electric and hydraulic system. The structure of design is of being precise, firm and durable. The part of the circuitry adopts the high accumulate circuit for controlled. It improves the part of safe controlled and cutting precision. The product is easy to operate, on the safe side, efficient, fashion and cheaper price. It is applicable for middle and small printing company and office. It is the optional cutting equipment for office.



Warning: this machine is allowed to cutting printed paper or books or soft leathers only. It is forbidden to cut any metal sheets or other hard objects do harm to the machine quality with this machine.



Children must not operate this machine.



Do not reach beneath the blade.



Do not touch the blade edge. Do not take out or transport the blade without protection.



Do not cut hard material or material which may splinter.



Please must use the outlet connected with earth wire.

Please read this manual carefully first in order to realize and use the machine. It will help you improve the work efficiency, bring into play the function of the machine, get the best effect of cutting, make for maintain of machine, prolong the service life of the machine.

To avoid the occurrence of any unexpected accidents or injury, please observe the relevant standards. Only one professional operator is allowed to operate this machine. (no children or non-professional persons are allowed to operate this machine.)

Please follow the safety precautions followed while operating and maintaining the machine.



The weight of this machine is about 150kgs(330.6lb), please put in balanced and in a clean place.



Please connect the power right according to instruction, the electric power must be stable: AC110V $\pm 10\%$ 60Hz 1150W. If the voltage is much higher or lower, the machine will not work normally. We recommend you use the AC power supply in order to improve the working quality and efficiency.



Please must use the outlet connected with earth wire.



Do not connect many electric products at one outlet. It is dangerous and easy to cause fire or electric shock.



Please turn off the electric power when you clean and maintain the machine.



Prevent water and other liquids from following into the interior of paper cutting machine.

Contents

I 、 Installation precautions	4
1.Check the wooden case	4
2.The installation of the machine	4
II 、 2.Basic operation	7
1.Manual CNC	7
2.Aliquot cutting	9
3.Automatic program	9
III 、 System Settings	10
IV 、 Machine parameters	12
V 、 The Lubrication and maintenance	12

IV.Parameter

Parameter

Model	T18
Max.cutting width	460x460mm (18.11x18.11in)
Max.cutting thickness	60mm (2.36in)
Precision	±0.3mm (±0.01in)
Press paper mode	Electric
Push paper mode	Electric
Safety	IR
Voltage	110V ±10% 60Hz
Power	1150W
Display	7 inch Touch Screen
GW	150kgs(330.6lb)
Packing size	960x680x1270mm(37.79x26.77x50in)

V.Lubrication and Maintenance

1.Lubrication

The machine should be lubricated every month.Draw out the cover,check and clean,fasten machine parts and drop lubricant on drive parts.Please avoid dropping the lubricant to the electric circuits and electric components.

2.Maintenance

■ Non-cutting objects are forbidden to place on the machine when working in case of the hard objects enter under the blade to damage the blade.The binded books with book nails are avoid to enter the cutting area in case of damaging the blade.

■ After working,please clean the machine,wax the blade and shut the power.

Find the system setting than press **Debugging** , enter the debugging page.

Debugging Page

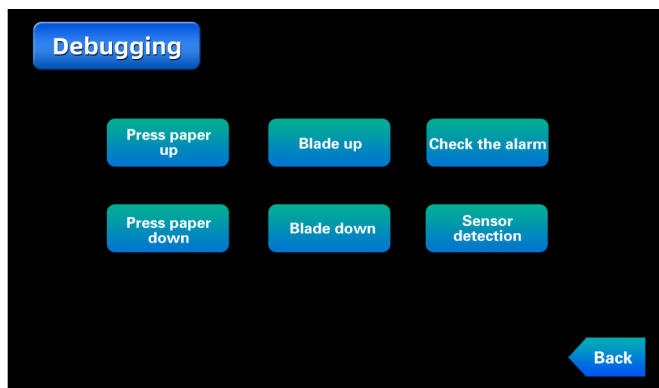

- Press paper up: press this button ,paper presser will be up
- Press paper down: press this button, paper presser will be down
- Blade up: press this button , blade will be up
- Blade down: press this button, blade will be down
- Check the alarm: press this button , can check the details of alarm information
- Sensor detection: press this button, can check the sensors operation

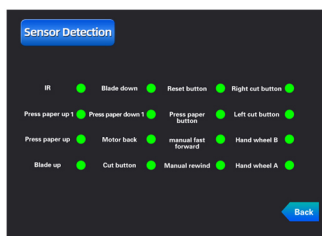
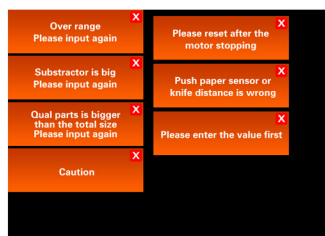

Press **Check the alarm** , enter the page of alarm information Press **Sensor detection** , enter the page of sensor detection. Green light on means sensors is not working , red light on means sensors is working



factory model is the factory debugging mode. Please do not press it or change the parameters.Any questions please contact with seller or factory.

I . Installation Precautions

1. Check the wooden case

After open the box, first check the machine and accessories, if any damaged or missing please contact the seller.

● Machine* 1	● Instruction *1	● Plastic strip *1
● Tool kits *1		

2. The installation of the machine and commissioning

2-1 The installation

* Please use a forklift to unload the hydraulic paper cutter .Open the wooden case, take out all the materials.Remove the fixed wooden which under the machine.

* Check packing list, ensure all items have and no missing.

* Check all parts of the machine and keep clean.



Installation diagram

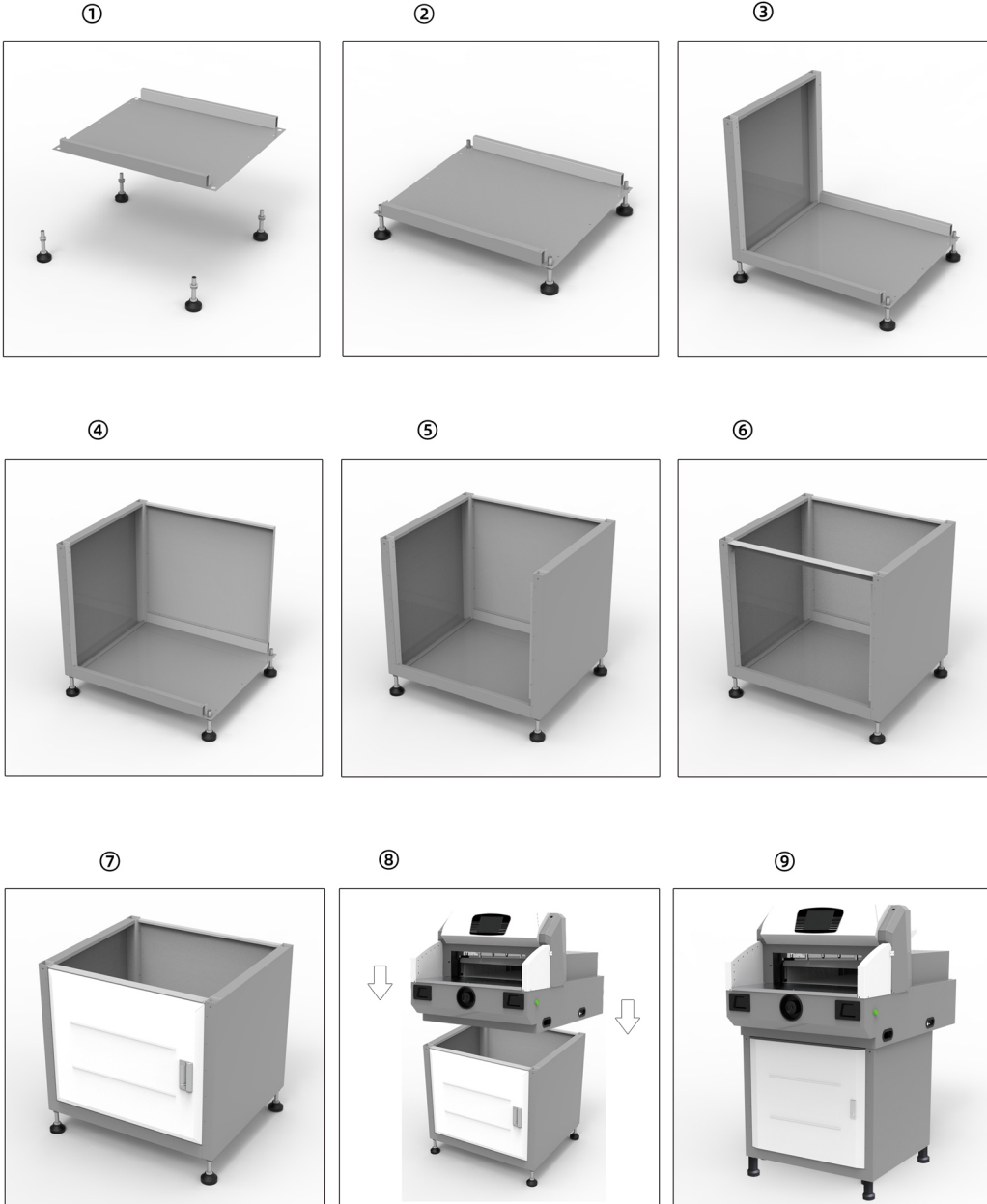

05

Steps

- ① Put the book on the cutting platform
- ② Select the group (total can be 99 groups)
- ③ Press “enter” confirm the data
- ④ Press “ Start” , paper pusher push to location of data 1.
- ⑤ Confirm that book is closely to the paper pusher
- ⑥ Press the buttons with two hands, after finish cutting and blade reset than release your hands
- ⑦ Paper push push to the next data automatically
- ⑧ Again step (6) till finish cutting

In automatic program mode there can be store 99 groups of data, each group have 12 value. Press “delete” can delete or modify the value. Press “ Clear ” can clear whole data of the group

III .System Setting

Press  enter the setting page

The page of system setting

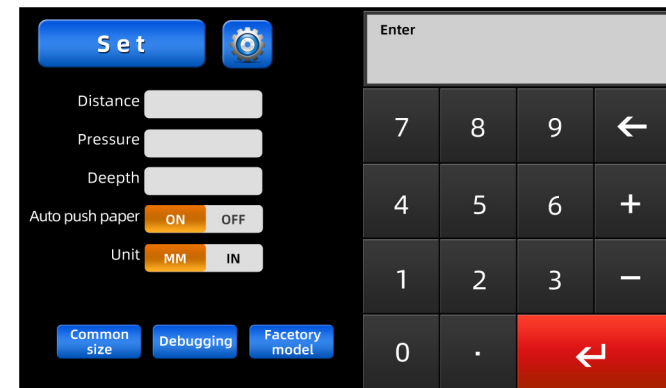

- Distance : The position of paper push is .
- Pressure: Can be adjustable according to requirements(Factory default is set)
- Depth: Can be adjustable according to requirements(Factory default is set)
- Auto push paper: If “on” , paper pusher will push automatically after cutting each time.
- Common size:Detailed introduction have in the CNC mode

10

2-2 Components Introduction

>>>2. Aliquot Cutting

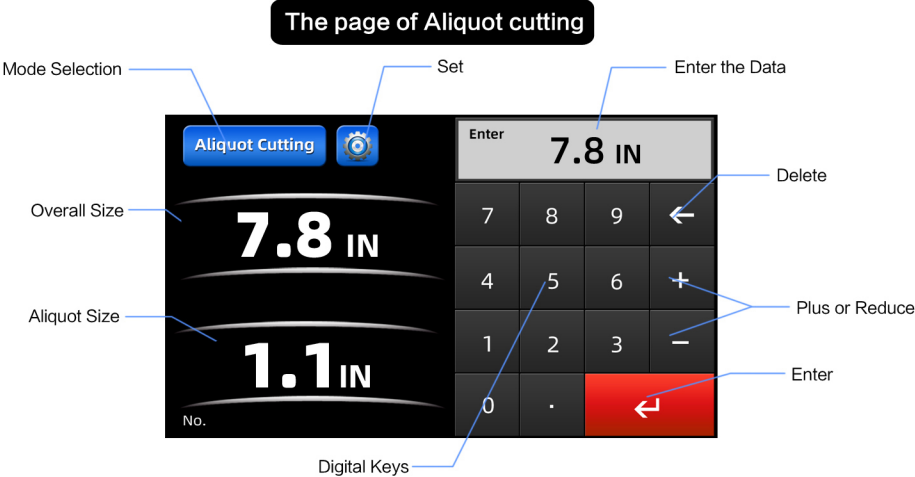

- Steps**
- ① Put the book on the cutting platform
 - ② Input the data of overall size which the book to be cut
 - ③ Input the date of aliquot size
 - ④ Paper pusher push to the position of overall size
 - ⑤ Confirm that book is closely to the paper pusher
 - ⑥ Press the buttons with two hands, after finish cutting and blade reset than release your hands
 - ⑦ Paper pusher push the data of aliquot distance
 - ⑧ Again step (6) till finish cutting

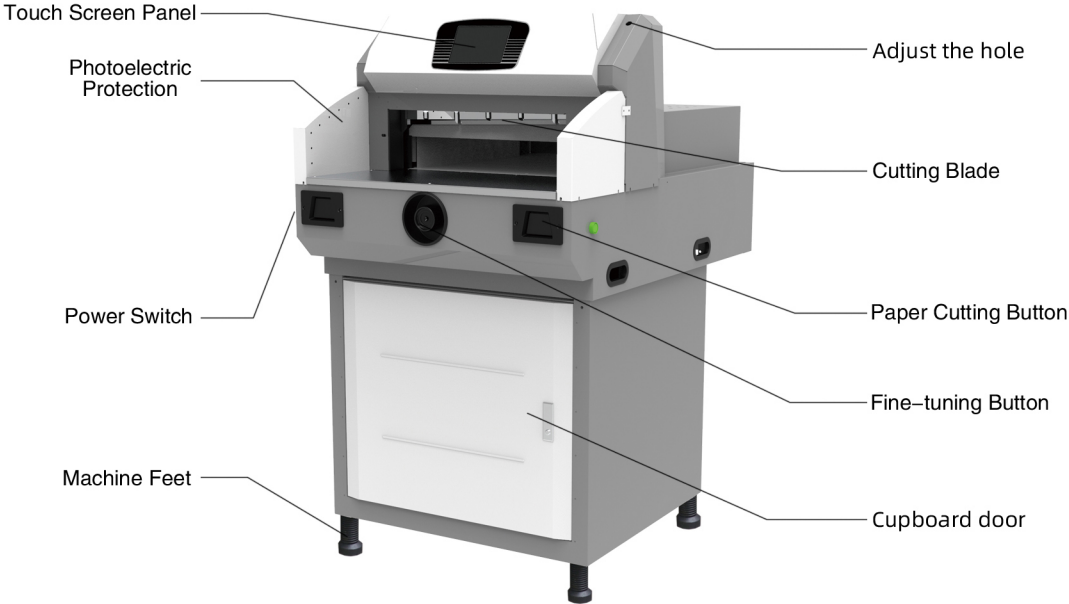

>>>3.Auto program

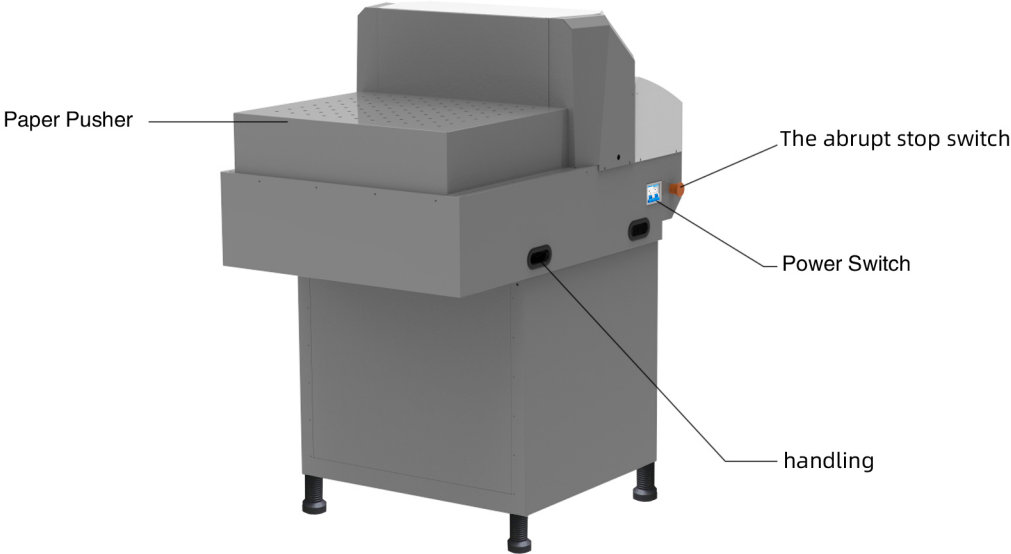
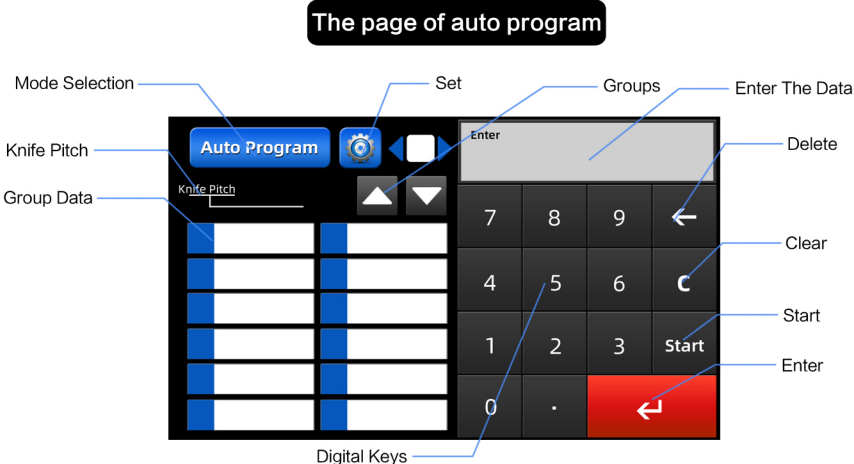

|| Basic Operation and Adjustment

1. Machine start-up

- Preparation works before starting. Examine if there is any items on the machine and clear machine up.
- Insert the power plug into AC110V ±10% 60Hz 1150W outlet.
- Turn electrical protection switch to position ' ON ' ,the display screen works and the paper pusher calibrate automatically.

The manual numerical control mode is entered by default after the welcome interface.

>>>1. Manual Numerical Control Mode

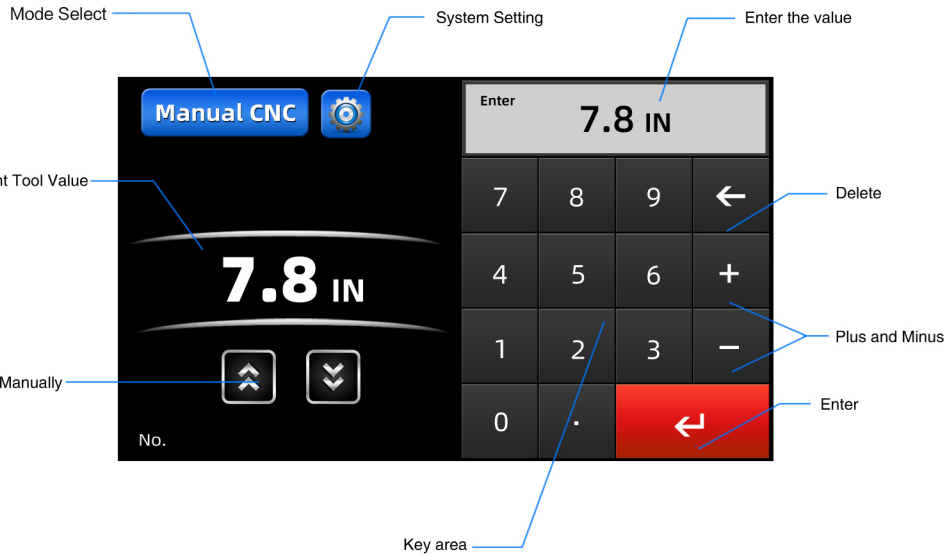

Operate Steps

1. put the book on the paper cutting platform
2. enter the value you need
3. press Enter
4. paper pusher moves to the corresponding position
5. Be sure the book is close to the pusher
6. Press the lower knife button with both hands until the cutting is completed. After the knife is reset, let go.

Plus and Minus

Press the Plus and Minus on the key area to calculate the cropped values to improve the cutting efficiency.

Press enter the setting page, press enter the common size page.

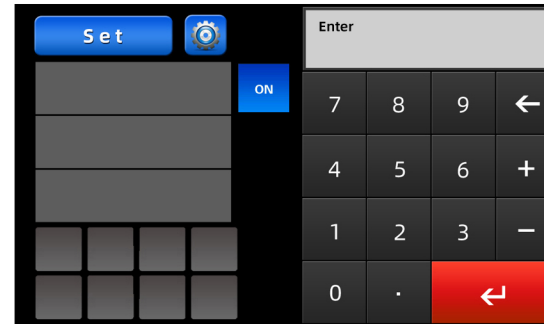

Three data can be entered in each group. Press the group which need input the data, and red cursor will move to the group, enter the data complete enter .

Program default 8 groups shortcuts , 4 is regular size data and another 4 is customize size data. (you also can modify the data)



Back to manual CNC page, under "knife pitch" you can find 8 groups shortcuts

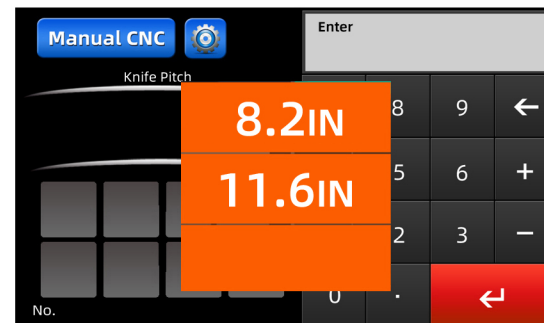

Choose one of group shortcuts, will come out 3 size data . Click on the data, paper presser will push to the appropriate position

You can press turn on the feature, or press turn off the feature.