

TYRE CHANGER

FT-3305D



INSTRUCTION

CONTENTS

I、 Summarize	2
1.1 Customer Notes	2
1.2 Warning Signs And Paste Parts Description	3
1.3 Technical Data	3
1.4 Transportation	3
1.5 Box Inspection	3
II、 Product Structure	3
2.1 Product Breakdown Drawing	4
2.2 Installation	5
III、 Setup	9
3.1 Separate The Bead	9
3.2 Demount The Tyre	11
3.3 Fit On The Tyre	12
3.4 To Inflate The Tyre	13
3.5 Routine Maintenance	13
3.6 Malfunctions Causes And Possible Remedies	14
IV、 Detailed Statement	15
V、 Breakdown Drawing	19
5.1 Column Assembly	19
5.2 Working Plate Assembly	20
5.3 Case Assembly	21
5.4 Pedal Assembly	22
5.5 Worm gear case and motor components	23
5.6 Air Cylinder Assembly	24
Accessories 1	25
Accessories 2	26

WARNING

The present instructions booklet is an important part of the product; please carefully study the warnings and instructions. This information is important for safely using and maintenance. Conserve this booklet carefully for further consultation.

I、 Summarize

1.1 Customer Notes

- 1、 Please read this manual carefully before use. The manufacturer will not responsible for any loss cause by not operating properly according to this manual.
- 2、 The warranty for switcher, oil water separator, motor, capacitance was three month; rubber gasket not under warranty; one year warranty for the rest of components on this machine..
- 3、 Please pay special attention to all the warning signs on the machine, in order to avoid accidents during the operation
- 4、 The machine must be good grounded before operation, max working pressure is 12bar.

1.2 Warning Signs And Paste Parts Description

Safety Warning Label:

- 01 Do not put your hand over the operation inside claws;
 - 02 Charging equipment, mainly security, check the grounding;
 - 03 Do not put your feet on the internal pressure of the tire shovel;
 - 04 Removing the bead, do not put your hand into the bead interior;
 - 05 Do not stand behind the operate arm when working;
- When the signs been lost or unclear, they should be changed or updated immediately;
 - Do not use this equipment when the warning signs missed;

Make sure the operator always saw the warning signs clearly.

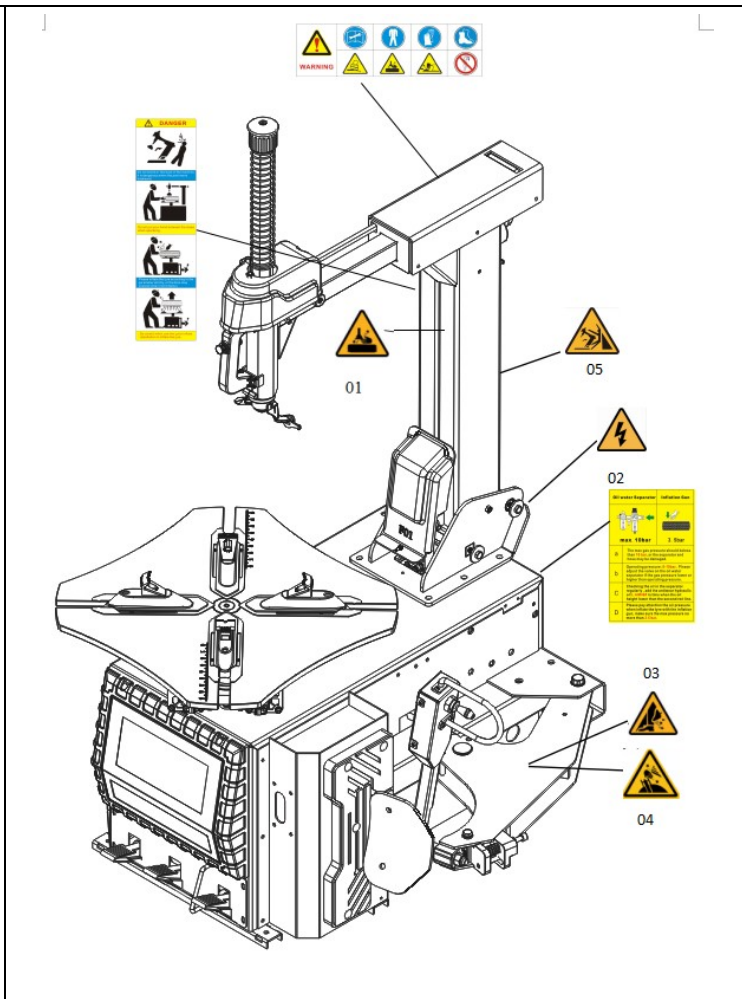

WARNING: When the security warning stickers defaced or off, please timely recovery! Machine operation is not allowed when the security stickers imperfect. Not allowed to set any object to make safety warning labels were obscured.

1.3 Technical Data

Rim diameter (external locking)	12~25"	Max. height	1610mm
Rim diameter (internal locking)	14~28"	Length	1066mm
Max wheel diameter	50"	Width	900mm
Wheel width	18"	Working speed	6~8 n / min
Working pressure	8-10Bar	Noise Level	72dB
Gross Weight	250KG		
Net Weight	224KG		
Voltage	110V/220V/380V 1PH/3PH 50/60HZ		
Motor power	1.1KW/0.75KW		
Packing size	1150X900X990mm		

1.4 Transportation

The machine must be originally packed and shipped as the logo information on the packaging, the packed machines must be moved with the forklift ,according to the position shown in Fig. 1

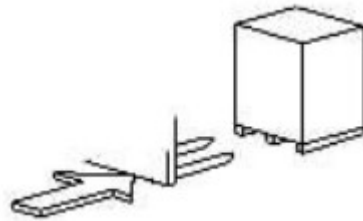

Fig.1

1.5 Box Inspection

Pull the small clip which is under the Package with a sharp forceps, removing the box and the plastic bag and checking equipment is OK, verify if all parts are damaged or missing, if in doubt, do not use the machine and Contact sales promptly.

II、 Product Structure

2. 1 Product Breakdown Drawing

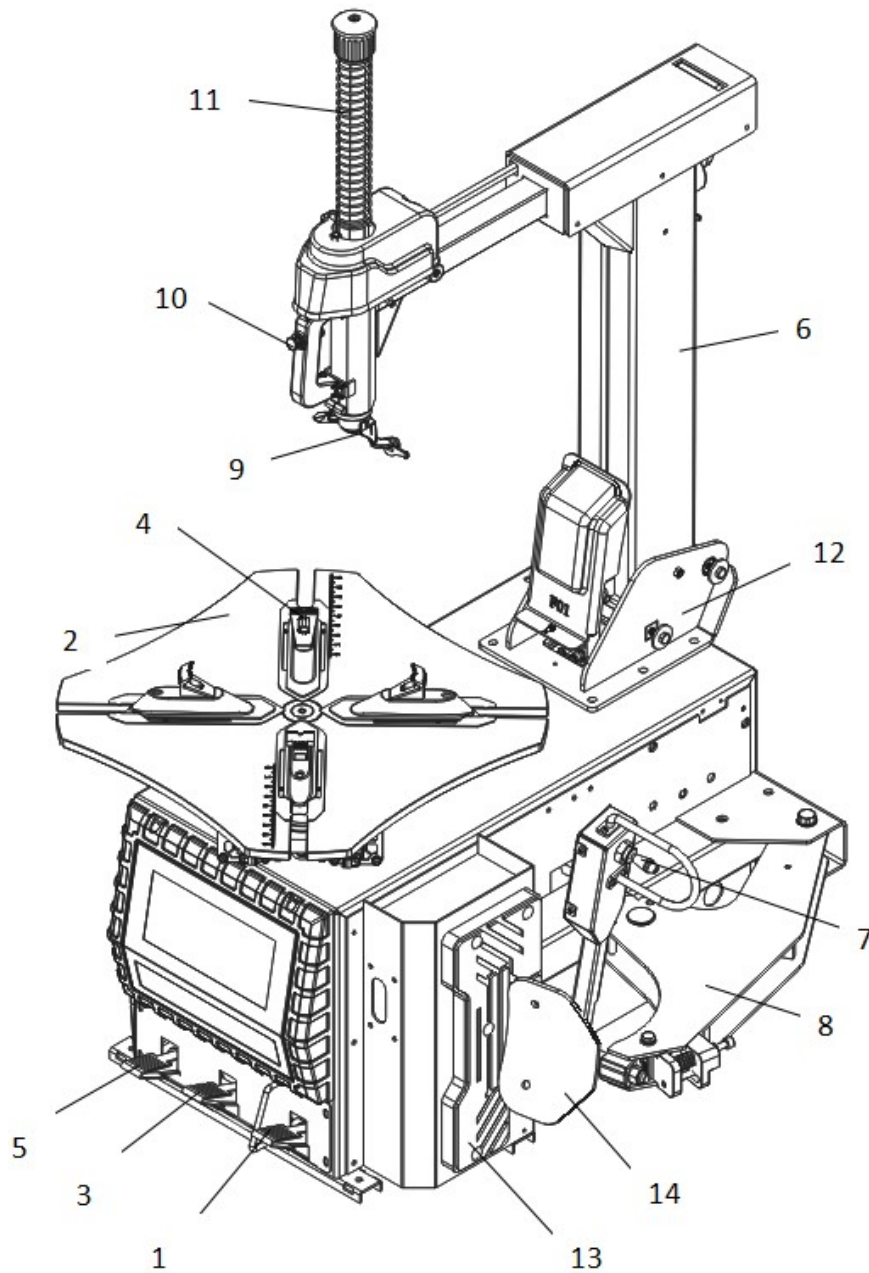

1、 Invertor control pedal	2、 Self-centering plates	3、Jaw control pedal
4、 Locking wedges	5、 Post backward and forward control pedal	6、 Post components
7、 Bead breaking control button	8、 Bead breaking arm	9、 Mounting head
10、 Locking switch	11、 Rocker arm	12、 Post base
13、 Anti-abrasion supports	14、 Pneumatic Tyre Separate Shovel	

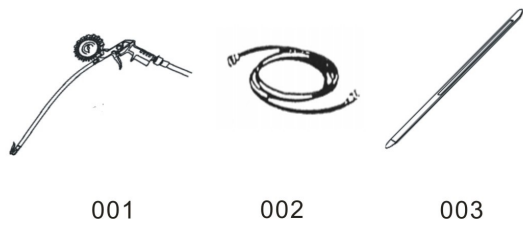

Random provided accessories as on Fig.2
 001- Inflation gun
 002- Inflator hose
 003- Crowbar

Fig.2

2.2 Installation

Space required: The installation location must be comply with safety standards. The machine must follow the instructions requirements, connecting the power and compressed air systems. Machine installation environment should be well ventilated. For safe and ergonomic use of the machine it is advisable to locate the machine a minimum of 500 mm from the back wall and 1000mm from the side wall.(see Fig. 3) If the machine is installed outdoors, it must have protective shed, rain and sun.

WARNING: Tyre Changer with motor are not used in place of flammable gases.

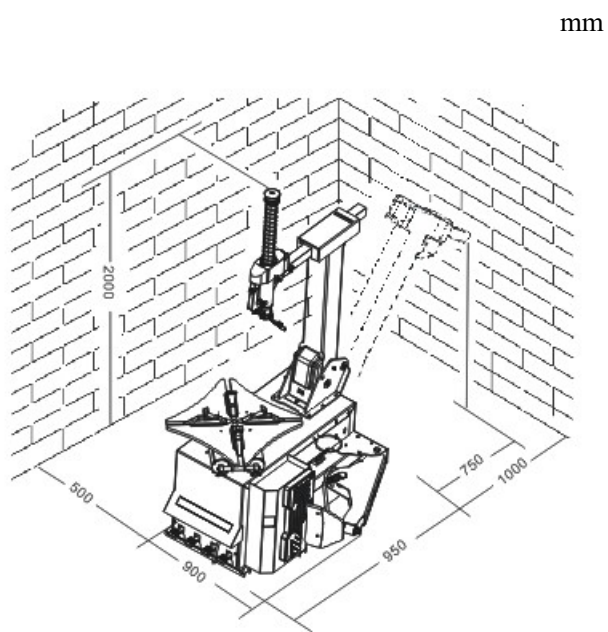

Fig.3

- The equipment place in the box as show in Fig.4, open the box and dismantle the C, D and the fixed device on other accessories.
- Lift out the post and put on a clear soft mat.



Attention:
 When the post assembly been moved, the slide arm D may fall down, be careful hurting.

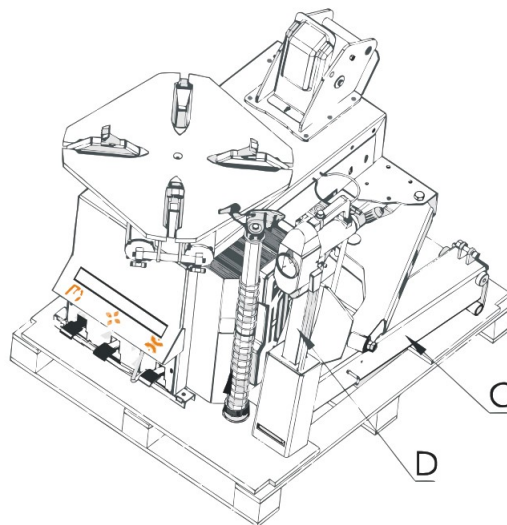

Fig. 4

Install the mounting head components:

As in Fig.5, firstly demount the H screw (M10*30), then take the cap B and spring A down. Through the E from arm D according the direction of arrow then install the A, B, tight the screw H.



Attention: Make sure the mounting head F on the right direction.

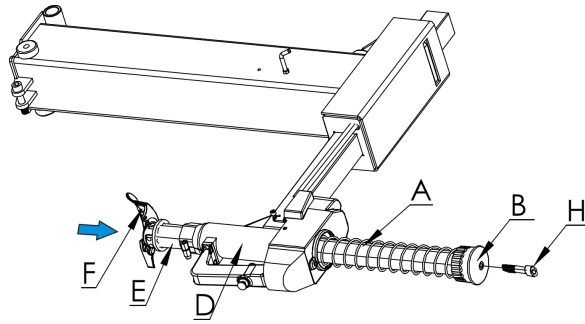

Fig. 5

Install the post:

- As in Fig. 6, take down the front fender D.
- Lift up the post E, as in Fig.6, make the hole alignment and put the pin H, tight the screw F(M12×25) with washer G. (If the post E can not been put in, please loosen the screw M. Tight it again after you put the post in.)
- Backward the post, insert the hose O into N(Fig.7).
- Pull the I to the highest point, slowly forward the post E with correct direction, make the hole alignment on E and I, put the screw J(M12*55) in and tight nut K(M12).

Set right the post and finished the installation.

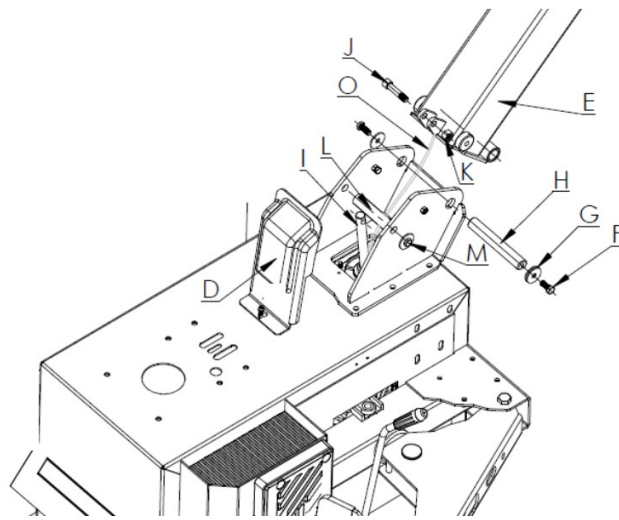

Fig. 6

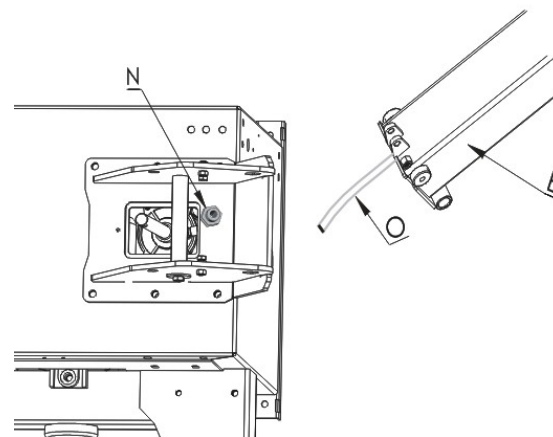

Fig. 7

Loose the screws on the pallet and put the equipment on the selected place, calibration level with a spirit level and put on expansion screw and tight. To prevent electric leakage, must be safety grounding. The operating area should be anti-slip ground.(Fig. 8)

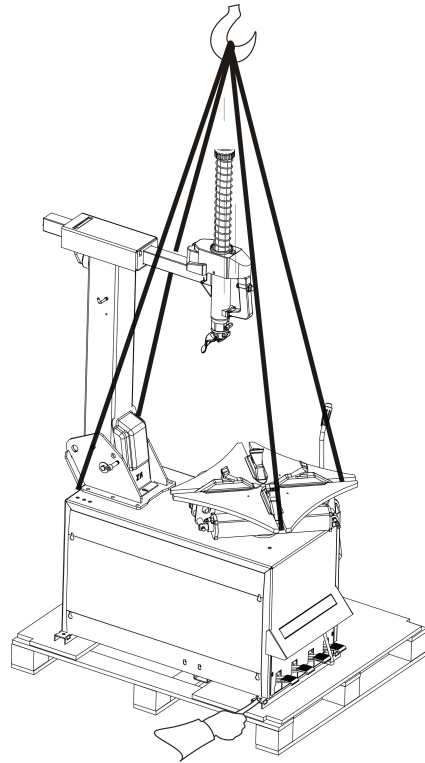

Fig. 8

The adjustment of Atomized lubricator or air service unit (optional) :

- *As in Fig. 9: 1-Atomized lubricator; 2-Oil water separator; 4-Gas-pressure meter.
- *Air pressure adjustment: Counter clockwise rotation the button 3 is reduced pressure, clockwise rotation the button is increase pressure. Press the button to lock it once the pressure is enough.
- * Oil water separator 2 was to filter out the water and impurities in the air. Unscrew the button 5 to outlet it when the water and impurities exceed the red line.
- * Atomized lubricator 1 was in the purpose to add quantitative lubr to the air in order to lubricate the cylinder and components in the valve. One drop of oil will drop in

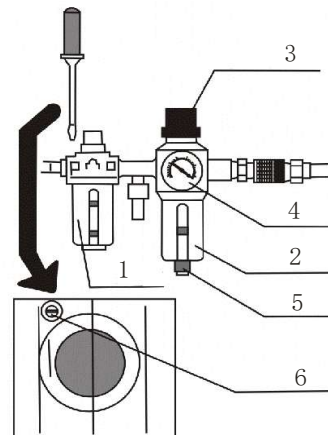

Fig. 9

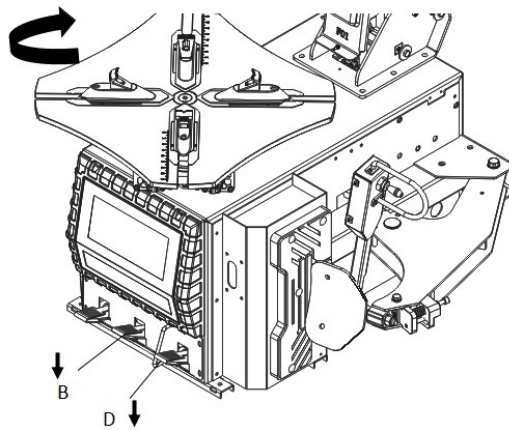

Fig. 10

the glass cup after Press the pedal B 3--5 time; if can not, adjust the screw 6 to make it.

- Before installing the connections, check the power supply and compressed air system with the machine technical parameters coincide. All electrical installation must be carried out by a qualified electrician
- Power connection socket should be located in the control of the operator, suggested height between 0.6-1.7 meter.
- The machine must be good grounded.
- Gas circuit system: Please connect the inflate gun A to the upper connector of the three direct links on the Atomized lubricator, then hang on the hook on the column.(Fig.9). Connect the external air source to the parallel direction connector of the Atomized lubricator S(as the arrow show on Fig. 9)



Attention:

The motor of the machine do not have phase-sensitive protector. Please connect the power supply according to the circuit diagram in this manual, or the manufacturer will not responsible for any accident.

OPERATIONAL CHECKS:

It is extremely important, for the correct functioning of the machine, that when the inverter pedal(D)is pressed the chuck rotates in a clockwise direction(see Fig.10).

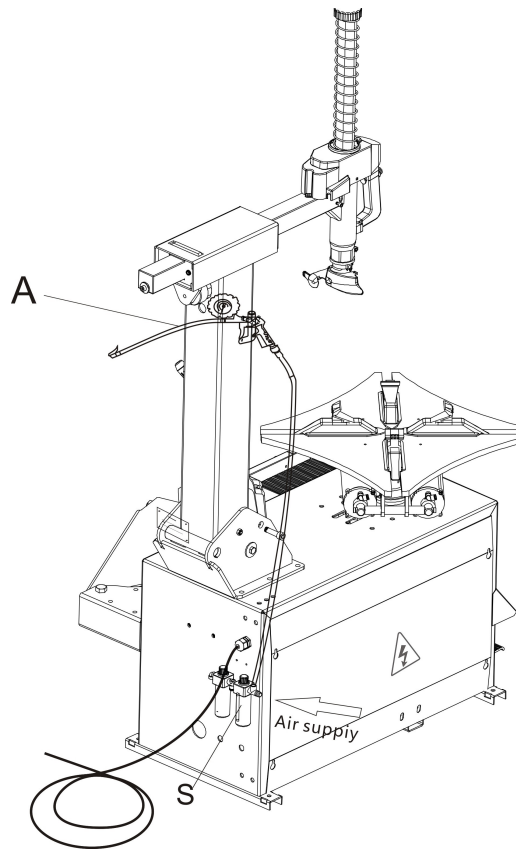

Fig. 11

III、 Setup

Operation of the Tyre Changer has three steps: apart the bead, remove the tyre, fit on the tyre.

WARNING: Before any operation, the operator should be dressed work clothes of tight sleeves and putted on non-slip shoes.

Completely deflate the tyre. Then remove wheel balancing weights to avoid any risks that could result from their presence.

Preparatory work:

Completely deflate the tyre and remove wheel balancing weights to avoid any risks. Please use specified tools to remove the wheel balancing weights and also remove the valve core and cap. (Fig. 12-a)



Attention:

Please lubricate the edge of the tyre fully before operation or the tyre edge may damage during the operation.(Fig. 12-b)

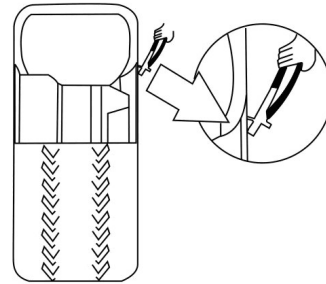

Fig.12-a

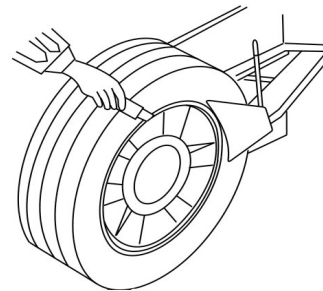

Fig.12-b

3.1 APART THE BEAD:

* Place the tyre between the separate shovel and rubber pad, put the shovel edge on the tyre bead, about 1 cm from the tyre rim(See Fig13-a), press the hand shank C(Fig 13-b), make the tire bead separate with the tyre rim.

* This operation is repeated at various points on the wheel until the bead is completely detached.

* Repeat the operation on the opposite side of the wheel.

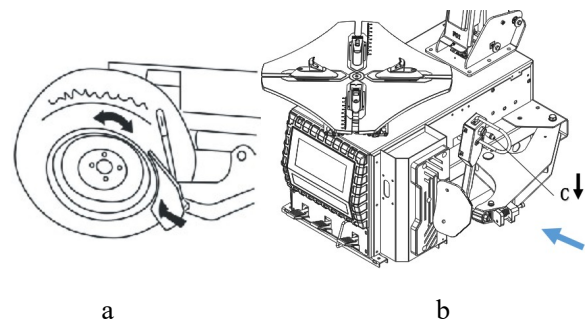

Fig.13

3.2 REMOVE THE TYRE:

- Press the button N (Fig. 14) to lock the slide arm and lever.
- Press the pedal A to make the column fall backward.
- Press the pedal B(Fig. 15) to adjust the wedges to the reasonable place. Place the wheel and locked it .

Note: The clamping way can be changed according to different rim shape.

①Option 1: Internal rim clamping(Fig. 16-a) , press the pedal B to make the wedges close up, place the rim on the working plate and clamp it.

②Option 1: External rim clamping (Fig. 16-b) , make the wedges apart with the pedal B, place the wheel and locked it.

- Make the column return to working position use the pedal A(Fig. 14); Press the button N(Fig. 17-a), make the L and M can move freely. Adjust the L and M to the reasonable position (as in Fig. 17-b) and lock them with button N. Make sure the mounting head around 2-3mm apart from the rim.
- Insert the crowbar to the tyre as show Fig.18.
- Pry the tyre edge on the front end of the mounting head(Fig. 19)

 Attention:

- If there with inner tube, please keep the valve

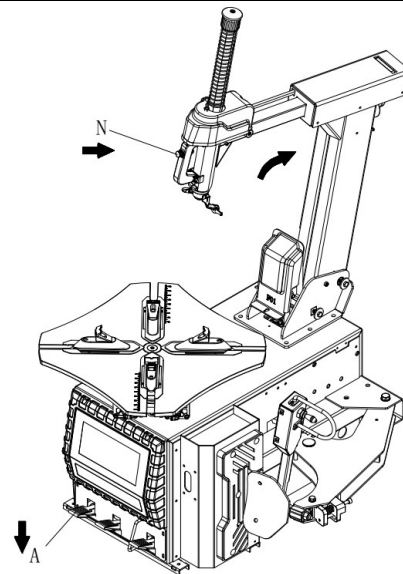

Fig.14

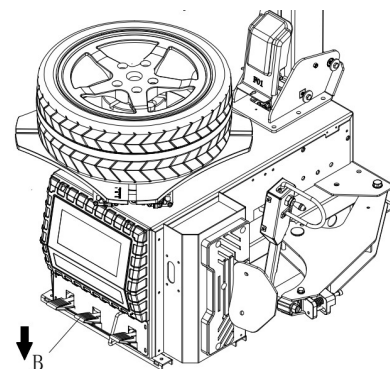

Fig.15

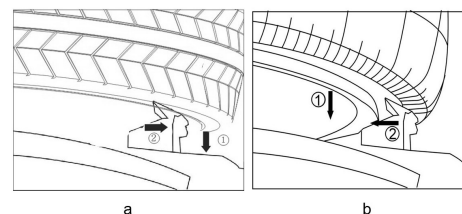

Fig.16

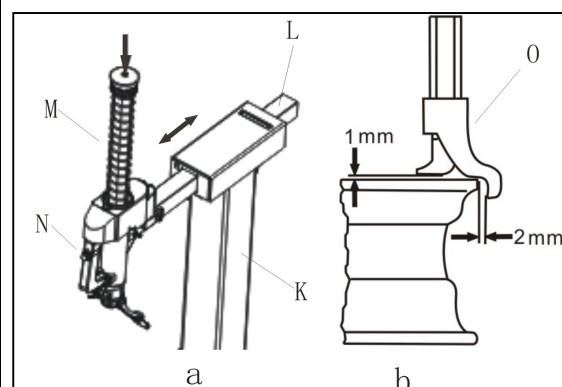

Fig.17

core around 10 cm from the mounting head to avoid any damage. (Fig. 20)

- Press the pedal D (Fig. 18) until all the tyre edge come out.

 Attention:

- The tyre edge may fall down from the mounting head if the tyre with very hard rubber. So please counter clockwise rotation the working plate 1-2cm before clockwise rotation to stop this happened.

- Please stop and counter clockwise rotation the working plate to correct the operation if hard to operate. (Fig. 18)

- Please take out the inner tyre first.
- Repeat the same operation to remove the second bead(Fig. 21)
- Backward the column and take down the tyre.

 Attention:

Keep your hand and body away from the machine in operating. It is very dangerous if the operator wear necklace, bracelet and loose cloths.

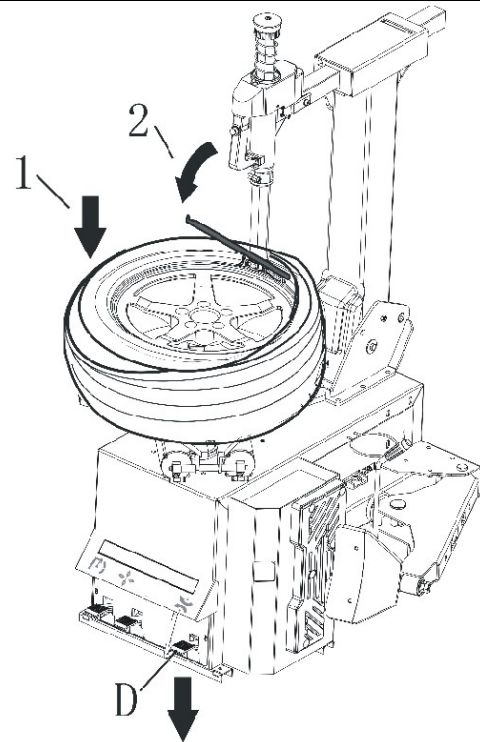

Fig.18

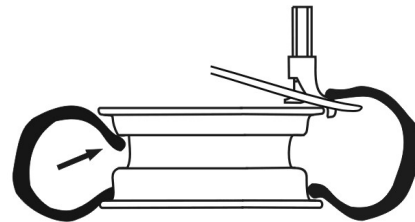

Fig.19

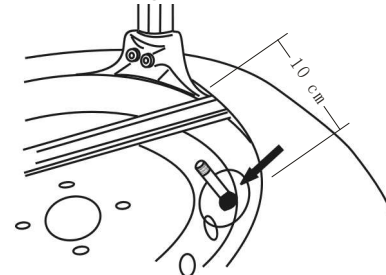

Fig.20

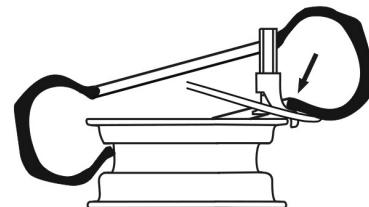

Fig.21

3.3 Fit On The Tyre:

 Introduction:

Check that the rim and tyre matching before operation.

- Lock the rim.
- Well lubricate the tyre edge..
- Place the tyre on the rim and make the column return to working position.(Fig. 22)
- Check and adjust the mounting head to match up the rim.

- Place the bead on the edge of the mounting head(H) and under the tongue(Fig.23)

- Depress the tyre and press the pedal D to make the working plate clockwise rotation until the under bead into the rim(Fig. 24-A)
- Please fit on the inner tube now if necessary(pay attention to the location of the valve core)
- Repeat the initial operation(see above) to locate the second bead.

In the case that the bead has difficulty descending from the head, it is necessary to “raise”(move upwards) the inverter pedal(A)making the chuck rotate in an anti-clockwise direction.

 NOTE:

- It is not necessary to lock the L and M if the rim size are same in the operation, just need to backward and return the column.
- The working plate always clockwise rotation when remove or fit on the tyre. Counter clockwise rotation just for correct operation.

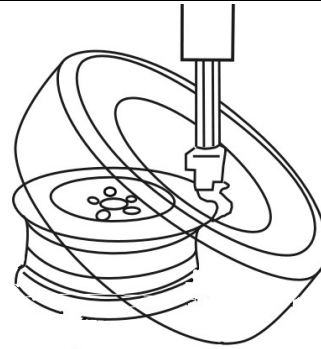

Fig.22

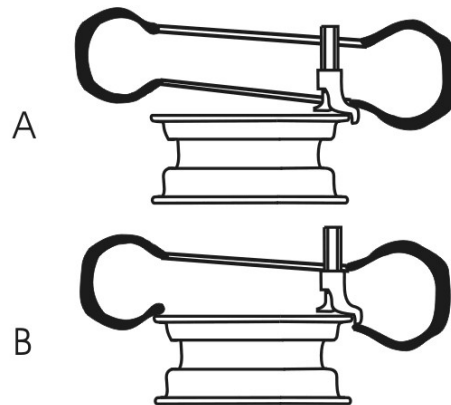

Fig.23

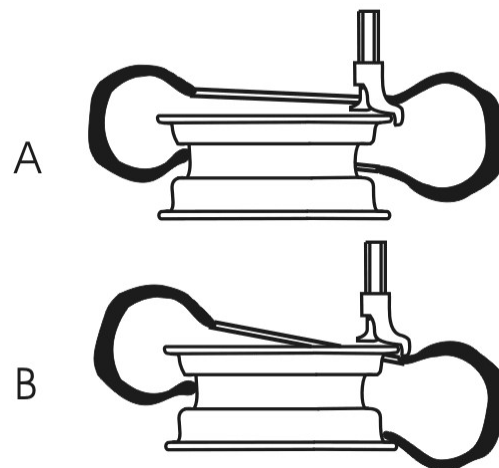

Fig.24

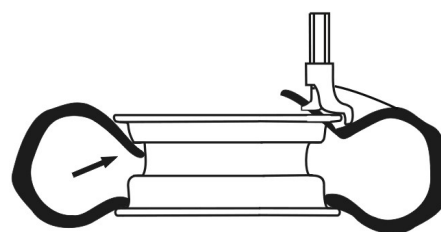

Fig.25

3.4 To Inflate The Tyre

WARNING: All the operation must refer to the manual. Inflating tyre is very dangerous, please carefully and Strictly abide by the operation procedures. The accident of tyres or rim is extremely dangerous when inflating, Explosion can make large power so that the tyres rush to the up or outward, causing the operator or the people around hurt or death.

Follow these steps:

- 1) Remove the valve core;
- 2) Clamp valve firmly with the pneumatic chuck;
- 3) Check that the rim and tire matching;
- 4) Check that the rim and the tire are well lubricated, then add some appropriate lubricant if necessary;
- 5) Inflating the tyre intermittently, check the pressure of gas meter, and check the wheel rim is positioning, if not positioning, continue the process above, it needs to take special steps when inflating the convex rim; (Fig. 26)
- 6) Go on to inflate the tyre intermittently to the pressure as need, within check the pressure of gas meter.



Fig.26

3.5 Routine Maintenance

WARNING: Before proceeding to any cleaning or maintenance operation, remove the plug from the electrical socket!

Keep the moving parts clean, washing them periodically with naphtha or kerosene and lubricating them with oil or grease .

In particular: Lubricator check and maintain the level of oil in the lubricator. The level must not go outside the min/max indicated. If necessary add liquid oil.

Air filter: periodically remove the water condensation that forms in the air filter.

Roller: check that the roller always turns freely. Periodically clean with naphtha and if necessary lubricate with oil.

Motor drive belt: check that the motor belt is at the correct tension and that it does not slip.

Inflation manometer: periodically check the figures on the pump manometer scale.

Set screw: using machine after 20 days, retighten the set screw on the jaw.

3.6 Malfunctions Causes And Possible Remedies

Malfunction	causes	Possible remedies
The chuck does not rotate in any direction	<ol style="list-style-type: none"> 1.Power plug not inserted. 2.Incorrect connection in the plug. 3.Electrical supply not suitable. 	<ol style="list-style-type: none"> 1.Check correct plugging and its connection.
Pressing the inverter pedal down causes the chuck to turn in an anti-clockwise direction.	<ol style="list-style-type: none"> 1. Polarity inverted. 	<ol style="list-style-type: none"> 1.Invert the connections in the power plug.
The chuck turns with insufficient power.	<ol style="list-style-type: none"> 1.Supply voltage wrong. 2.Slack drive belt. 	<ol style="list-style-type: none"> 1.Check the correspondence between the supply voltage and that on the maker's plate. 2.Adjust the belt tightener.
The chuck does not lock the rim correctly	<ol style="list-style-type: none"> 1. The pneumatic supply is not connected to the machine. 2. Insufficient pressure in the pneumatic system. 3. Pressure reducer is closed or badly adjusted (for versions with this device). 	<ol style="list-style-type: none"> 1.Connect the pneumatic supply. 2.Correct the supply pressure. 3.Open or correctly adjust the pressure reducer.
The bead breaker does not have sufficient power to break the tyre bead.	<ol style="list-style-type: none"> 1.The pneumatic supply is not connected to the machine. 2.Insufficient pressure in the pneumatic system. 3.Pressure reducer is closed or badly adjusted (for versions with this device). 	<ol style="list-style-type: none"> 1.Connect the pneumatic supply. 2.Correct the supply pressure. 3.Open or correctly adjust the pressure reducer.
Working arm backward or can not return freely.	<ol style="list-style-type: none"> 1, Underpressure 2, Throttle valve broken. 	<ol style="list-style-type: none"> 1, Checking and make sure the pressure at least 8bar. 2, Change the throttle valve

IV、 Detailed Statement

If the equipment parts damaged, please purchase them according to code in this statement from the dealer or manufacturer.

No.	Description	Qty.	No.	Description	Qty.
105	Vertical Column	1	156	Locking screw M12x35	2
113	Screw M10×30	1	157	Thin nut M12	2
114	Washer	1	158	T-union RC1/8-4	1
115	Washer Φ10	1	159	Air hose jacket	1
116	Complete Mounting Head	1	160	Pin Φ10x50	1
117	Rubber Washer	1	161	Wheel base	1
120	Locking nut M10	1	162	Needle bearing Φ10xΦ17x12	2
121	Vertical Rod	1	163	Screw M8x25	2
122	Spring	1	164	Screw M8×20	2
123	Cap	1	165	Locking board	1
124	Thin nut M10	1	166	Spring	2
125	Knob	1	167	Screw	2
126	Screw M8×45	1	168	Screw M10x45	2
131	Pothead	1	169	Cylinder cover	1
132	Nut M8	1	201	Jaw	4
133	Screw M8×35	1	202	Slide	4
134	Screw M6X25	3	203	Elastic cylindrical pin 5x16	8
135	Complete cylinder	2	204	Wear Plate	4
136	Zerk M8	1	205	Turn Table	1
137	Column pad	2	206	Claw Seat Plate	2
138	Screw M8×12	3	207	Pin	4
139	Nut M10	4	208	Connecting Rod	4
140	Screw M10x35	2	209	Rod Knot	4
141	Locking nut M12	1	210	Washer Φ12	8
142	Washer φ12	2	211	Washer Φ12	4
143	Screw M12x55	1	212	Screw M12x85	4
144	Complete arm cylinder	1	213	Screw M6×12	4
145	Washer φ6	1	214	Complete Clamping Cylinder	2
146	Screw M6x12	1	215	Retainer Ring Φ12	4
147	Protection cover	1	216	Claw Seat Body Welding Assembly	2
148	Screw M6×20	5	217	Retainer Ring Φ65	1
149	Stop block	1	218	Thin Nut M6	4
150	Tension spring	2	219	Control Plate	2
151	Nut M6	2	220	Sleeve	1
152	Complete handle	1	221	Cap	1
153	Screw M6×20	4	222	Screw M16×30	1
154	Rocker Arm	1	223	Screw M10×25	4
155	Locking board	1	224	Washer	4

225	T-junction Φ8	2		332	Column base	1
214-1	Piston Rod	1		333	Screw M12x35	6
214-2	L-union (8-R1/8")	2		334	Washer φ12	6
214-3	Locking Nut M8	8		335	Washer φ12	6
214-4	Front Flange	1		336	Screw M8x30	2
214-5	O-seal Φ20×2.65	1		337	Nut M8	4
214-6	Y-seal Ring 35x20x8	1		338	Pin roll	1
214-7	Washer	1		339	Balance pole	1
214-8	Tightener	4		340	Screw M10x25	4
214-9	Cylinder Casing	1		341	Upper cover	1
214-10	Piston	1		342	Cover	1
214-11	Washer Φ12	1		346	Scaffold boards	1
214-12	Locking Nut M12	1		347	Handle	1
214-13	O-seal Φ 67×3.5	2		348	Screw M6x10	8
214-14	Rear Flange	1		349	Hand Valve	1
301	Chassis	1		350	Installation block	1
302	Filter And Pressure Reducer +Lubr	1		351	Washer	1
303	Screw M16x110	1		352	Screw M12X18	2
304	Washer φ16	3		353	Connecting shaft Sleeve	2
305	Pull Pin	1		354	Spring	1
306	Locking Nut M16	3		355	Screw M10X80	1
307	Tension Spring	1		356	Nut M10	2
308	Washer	5		357	Screw M10X90	1
309	Screw M10x25	1		302-1	L-union(R1/4-8)	1
310	Taper Knob	1		302-2	Air Lubricator	1
311	Breaker Arm	1		302-3	T-union(R1/4-8)	1
312	Bead Breaking Plate	1		302-4	Screw ST6.3x13	2
313	Pad	1		302-5	Reducing Valve	1
314	Box Support	1		302-6	Quick Union PM20	1
315	Screw M10×25	5		302-7	Quick Union SP20	1
316	Washer φ10	5		302-8	AFR Support	1
317	Rubber Buffer-1	1		401	Cam	2
318	Rubber Foot	5		402	Complete 5-way Valve A	2
319	Screw M6x16	4		403	Screw M6x16	12
320	Side Cover	1		404	Washer φ6	16
321	Box Lid	1		405	Nut M6	3
322	Box	1		406	Tension Spring	2
323	Water Joint	1		407	Pedal Bracket	1
324	Screw M3	2		408	Cam Connecting Rod	1
325	Screw M3x8	2		409	Retainer Ring Φ14	2
326	Connector 600V 45A 5P	1		410	Washer φ14	2
330	Straight valve 1/8-8	1		411	Rod	1
331	End cap1/8	1		412	Pedal	3

413	Plastic Casing-1	1		502	Screw M10x55	6
414	Locking Nut M8	2		503	Spring washer ϕ 10x2	12
415	Connecting Screw(Pedal)	1		504	Washer ϕ 10x2.5	6
416	Plastic Casing-2	1		505	Rubber Washer	6
417	Torsional Spring	1		506	Washer ϕ 10x2	10
418	Screw M8x50	1		507	Screw M10x30	2
419	Washer ϕ 8	1		508	Screw M10x35	4
420	Screw M8x16	2		509	Locking nut M10	4
421	Connecting Screw(Switch)	1		510	Screw M8x75	2
422	Pitman	1		511	Nut M8	4
423	Screw M3.5x16	1		512	Washer ϕ 8x1.6	4
424	Screw M6x20	1		513	Washer ϕ 8x2	4
425	Picks	1		514	Locking nut M8	2
426	Locking Nut M6	1		515	Motor Support	1
427	Screw M4x10	2		516	Motor 0.75KW 220V/50HZ	1
428	Spring washer ϕ 4	2		517	Key 6x28	1
429	Washer ϕ 4	2		518	Motor Pulley	1
430	Cam Cover	2		519	Set Screw M8x12	1
431	Screw M3.5x10	2		520	Belt A	1
432	Flat Spring	2		501-1	Plug Screw BM16x1.5	1
433	Reverse Switch	1		501-2	O-seal 16x2.65	1
434	Screw M6x25	5		501-3	Pin 8x20	2
435	Switch jacket	1		501-4	Screw M8x35	10
436	Pedal cover	1		501-5	Upper Cover	1
437	Screw M6x16	4		501-6	Bearing 6010	1
438	Lock nut M6	2		501-7	Worm Gear	1
439	Pedal handle	1		501-8	Key 14x50	1
440	Complete 5-way Valve B	1		501-9	Roller Bearing 30205	2
402-1	Rod	2		501-10	Plastic Cap	1
402-2	Spacer B	4		501-11	Bearing 6208	1
402-3	O-seal ϕ 9.75x4	24		501-12	Bottom Cover	1
402-4	Spacer A	10		501-13	Worm Gear Shaft	1
402-5	Complete 5-way Valve	2		501-14	Screw M8x20	1
402-6	Screw M4x10	8		501-15	Washer ϕ 8x2	1
402-7	Connector	2		501-16	Gear Box Pulley	1
402-8	Latch	2		501-17	Seal 25x40x7	1
402-9	Lock Nut M8	2		501-18	Worm screw	1
402-10	Pad	4		501-19	Spring Washer ϕ 8x1.6	1
402-11	Silencer	4		501-20	Key 6x22	1
402-12	Union R1/8-8	6		601	Valve Core	1
402-13	Cotter Pin 4x20	2		602	Union RC1/8-8	3
440-1	Throttle Valve	2		603	O-seal ϕ 65x2.65	5
501	Complete Gear Box	1		604	Valve Pocket	1

V、 Breakdown Drawing

5.1 Column Assembly

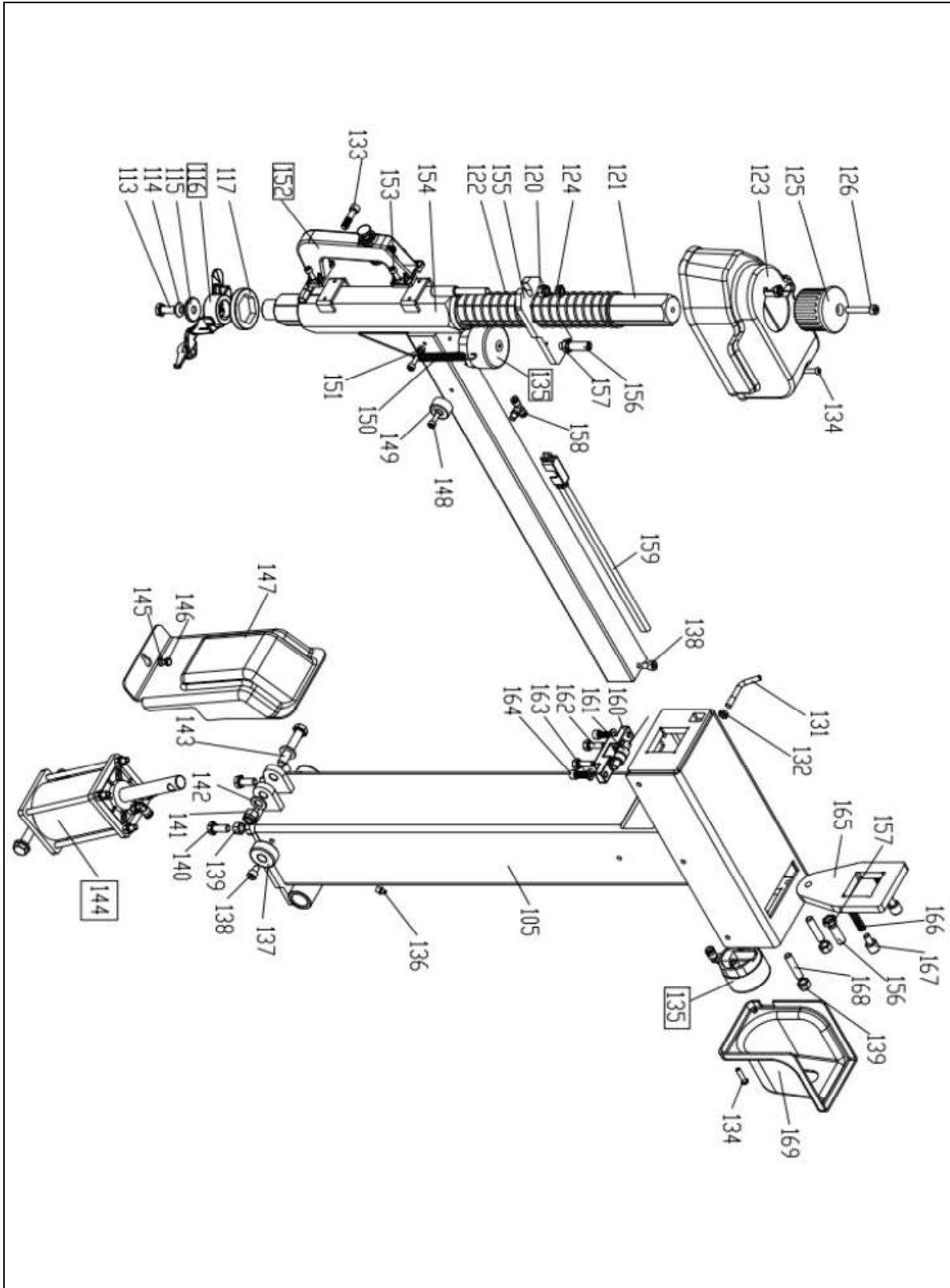

Fig.27

5.2 Working Plate Assembly

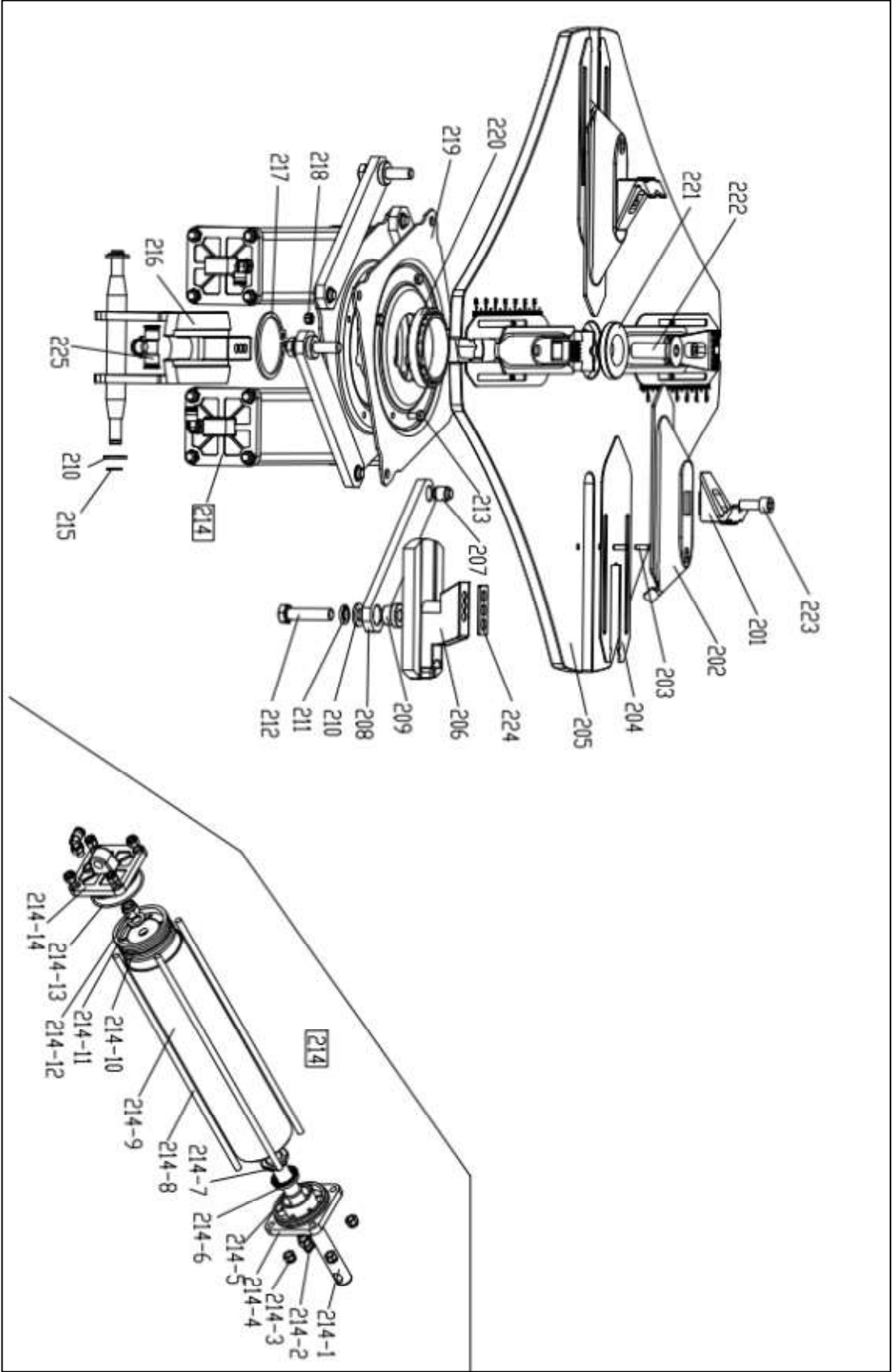

Fig.28

5.3 Case assembly

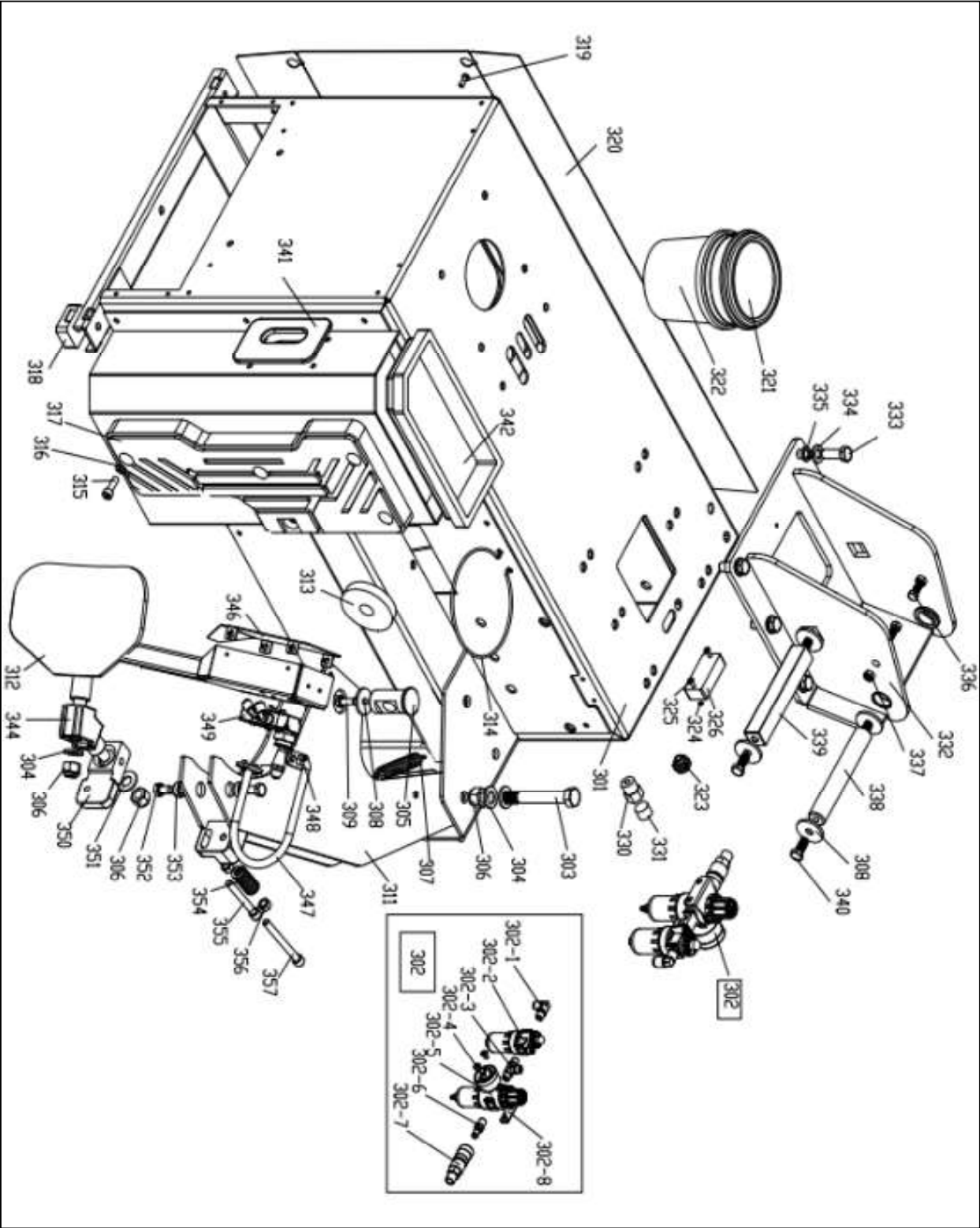

Fig.29

5.4 Pedal Assembly

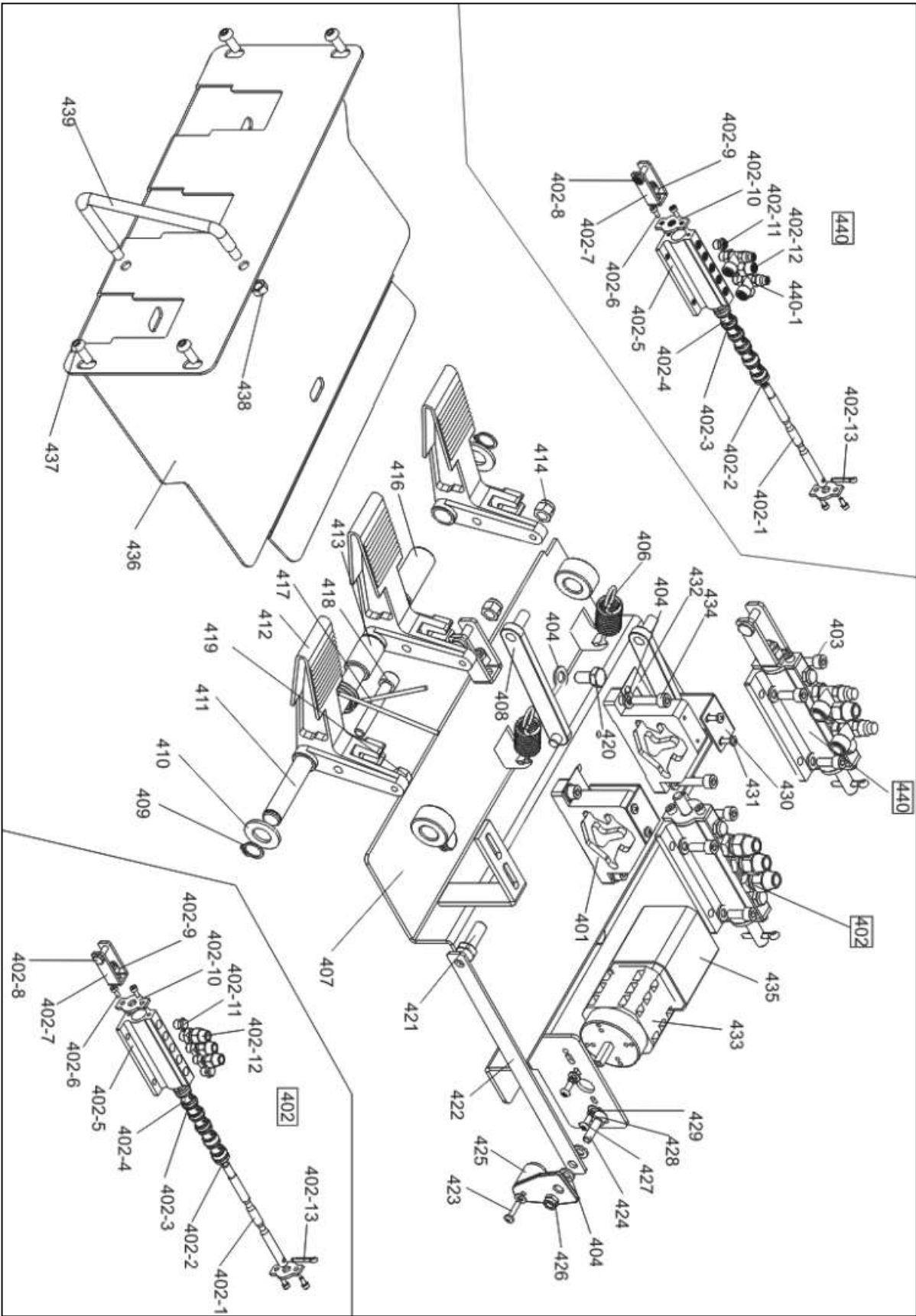

Fig.30

5.5 Worm gear case and motor components

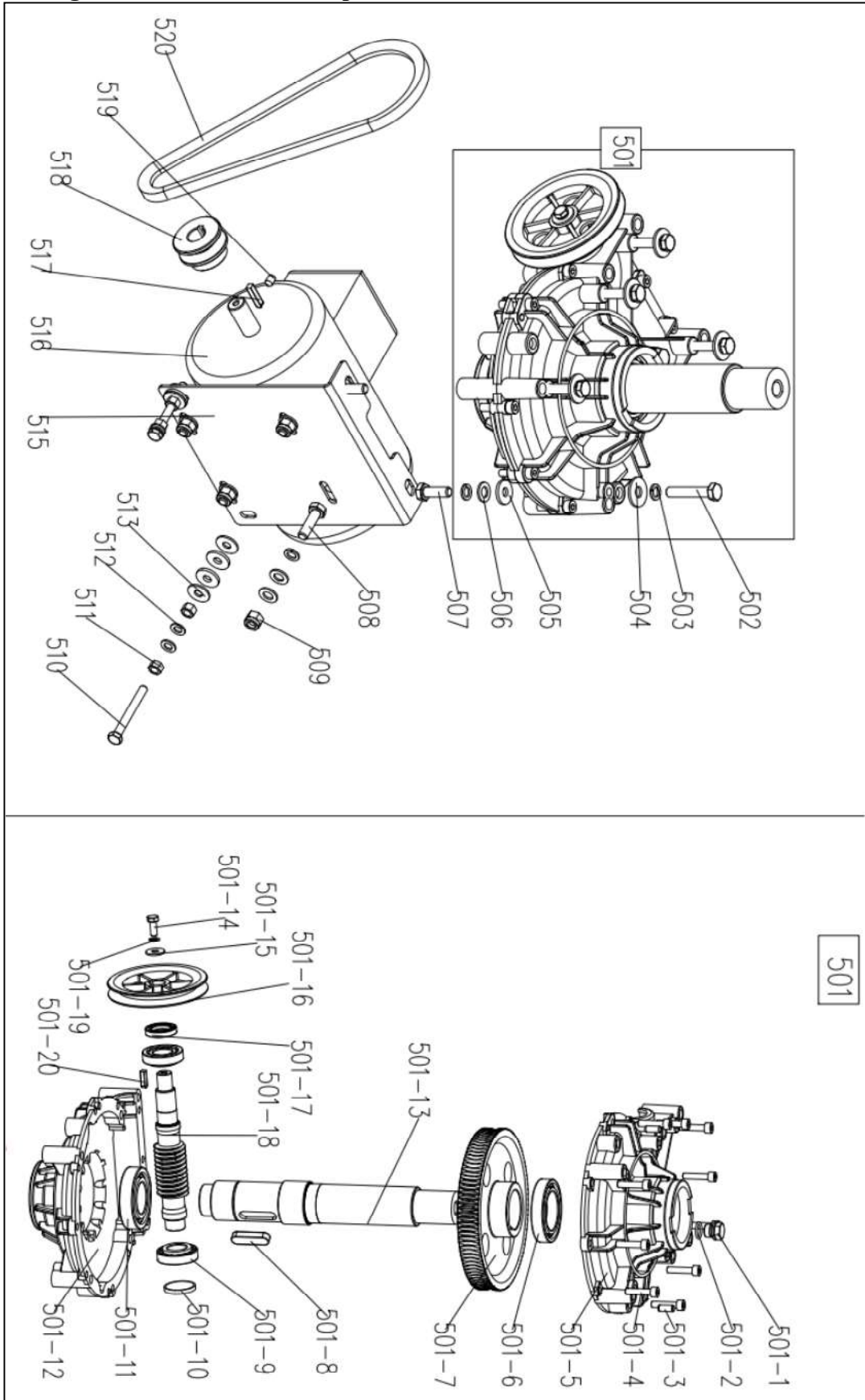

Fig.31

5.6 Air Cylinder Assembly

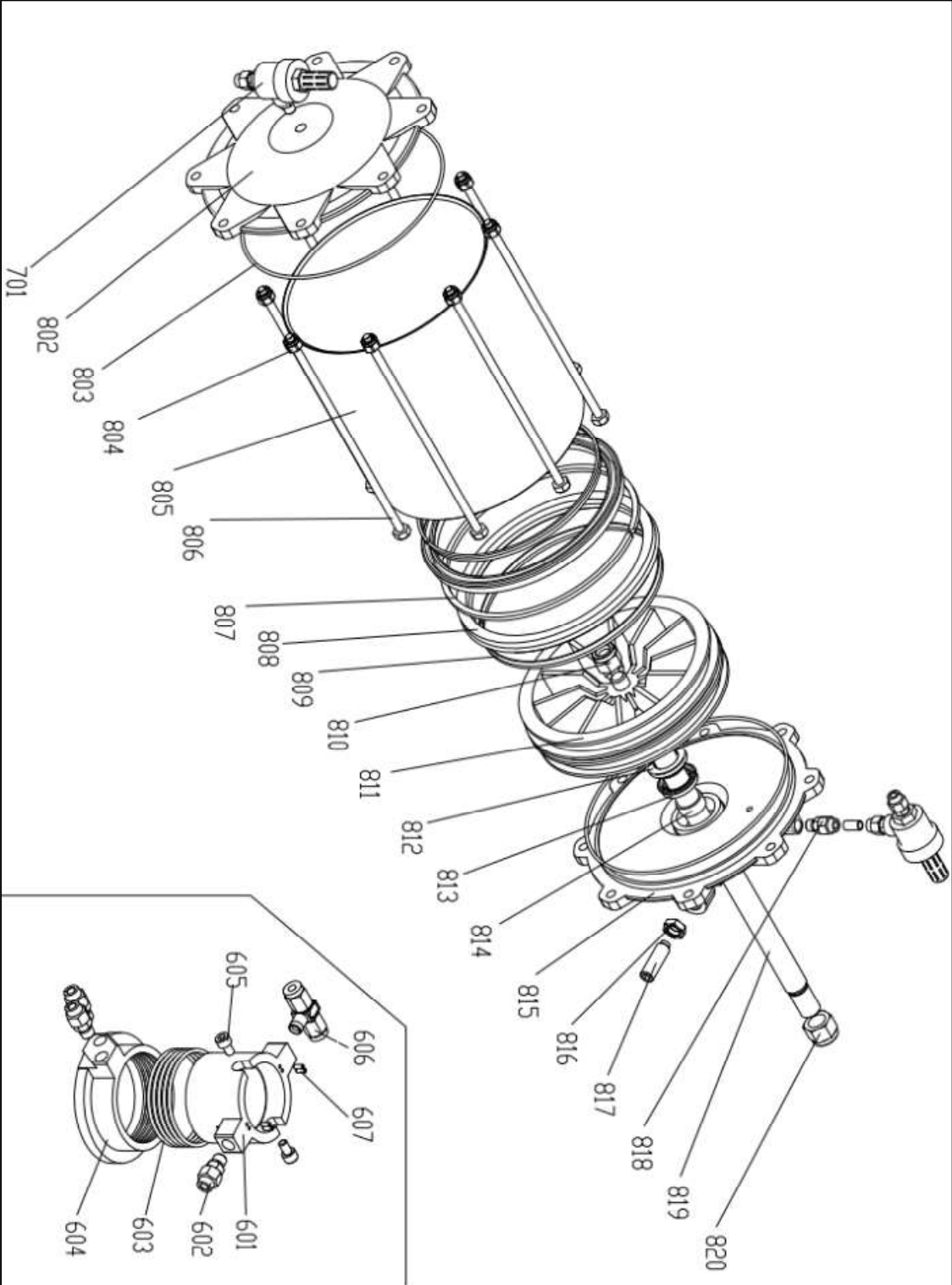

Fig.32

Electric Schematic Diagram

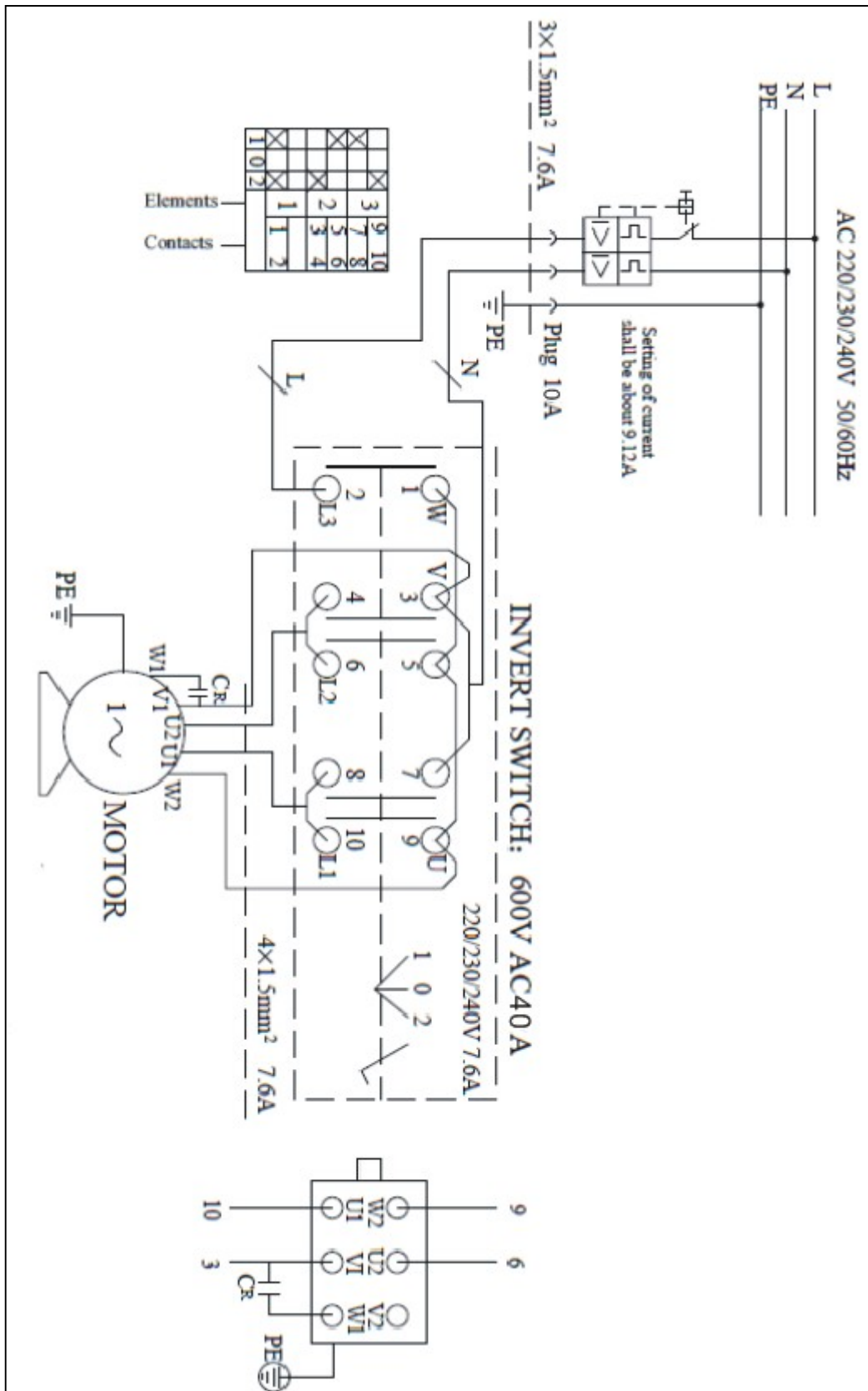

Fig.33

Gas Circuit Principle Diagram

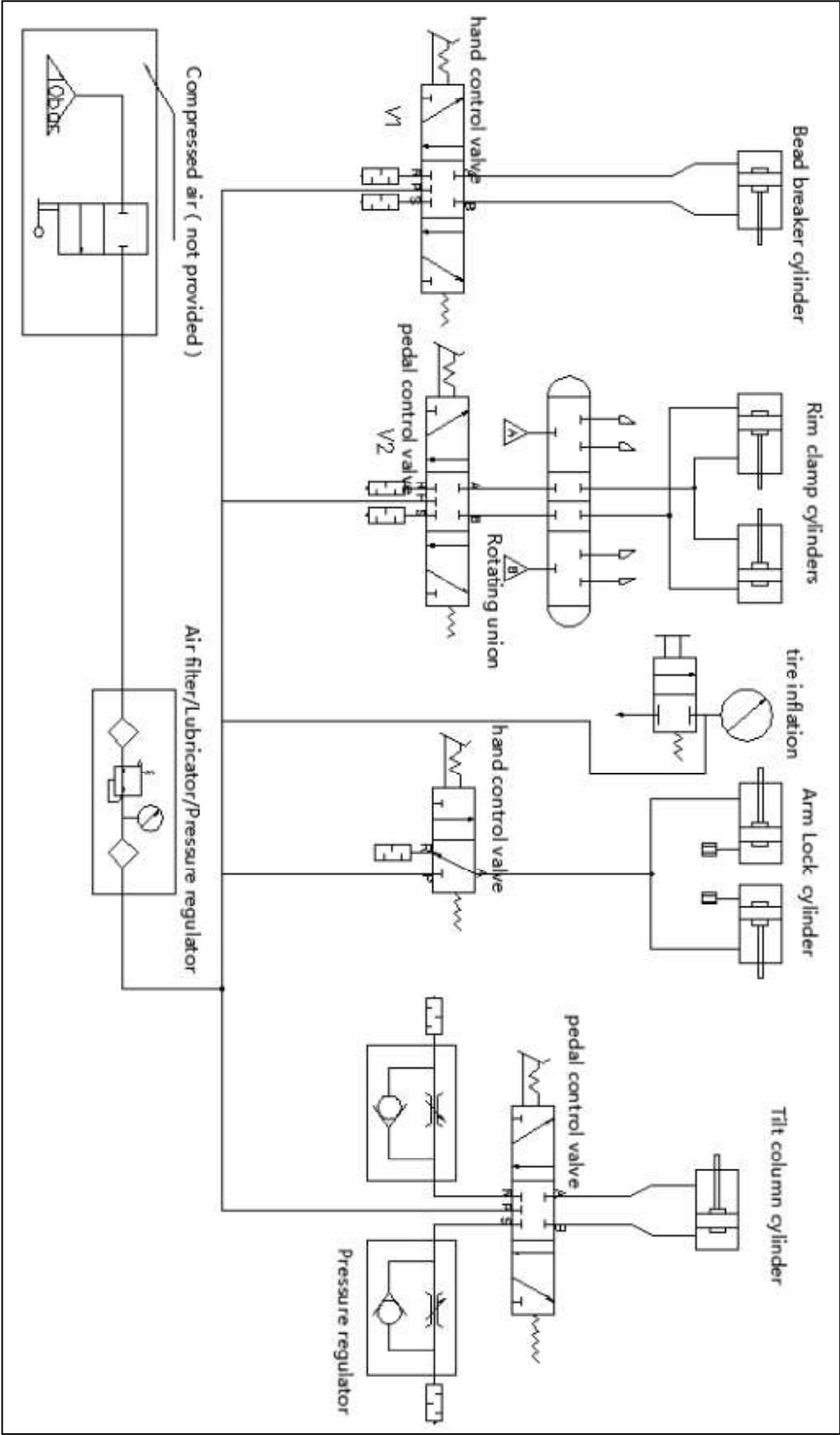

Fig.34