OPERATION MANUAL

Double Column Band Sawing Machine

Model GH4240

Contents

1. Main Specification	1
2. Main Components of Sawing Machine.....	1
3. Selection of Teeth Number of Saw Blade for Variable Stocks.....	2
4. Attention for Usage of New Saw Blade Selected.....	3
5. Installation Methods for the Saw Blade.....	4
6. Fixture Stock.....	5
7. Hydraulic System.....	6
8. Electrical Principle Chart.....	8
9. Operation and Maintenance	9
10. Usual Major Faults and Solution.....	10
11. Precautions.....	14
12. Packing List.....	14

1. Main Specification

Parameter	GH4240
Max. cutting range (mm)	Φ400□ 400x400
Cutting speed (m/min)	Three grade:27/45/69
Feeding speed adjustment	Hydraulic stepless
Blade model (mm)	5000x41x1.3
Clamping type	Hydraulic
Main motor power (kw)	4.0
Hydraulic pump power(kw)	0.75
Coolant pump power(kw)	0.125
Type of main transmission	Worm bar
Machine layout (mm)	2500x1300x1600

2. Main Components of Sawing Machine

Saw frame	Base	Clamping device	Saw wheel	Electrical cabinet	Coolant tank	Operation station
Sub-column	Leading device	Oil pump	Motor	Reducer	Coolant pump	Main oil cylinder
Clamping cylinder	Working light	Driving wheel	Tension base			

3. Selection of Teeth Number of Saw Blade for Variable Stocks

Cutting length (mm)	Less 15	15-25	25-75	75-150	150-250
Teeth number (difficult)	12-10	10-8	8-6	6-4	4-3
Teeth number (general)			8-6	4-3	3-2

4. Attention for Usage of New Saw Blade Selected

1. Before loading the new saw blade, keeping the cleaning of the saw blade wheel and checking if coolant and hydraulic system work normally
2. Fine and coarse teeth saw blade should be applied according to size of stocks, please check the above item 3 to choose the suitable saw blade for your stock so that no any teeth of saw blade broken. For example, if using small teeth blade (6 teeth blade) to cut big work-piece (150mm diameter steel rod) will cause too much iron scurf between teeth, further decrease blade service life.
3. Cutting speed should be lower while cutting material with quite high hardness
4. The saw blade selecting also should be considered as per the shape of the stock, teeth-change blade should be used for the profile stock, keep at least two tooth inside the stock constantly
5. Reasonable to choose coolant liquid for variable stock, oil and water ratio can be 1:5 for high alloy steel and 1:10 for low alloy steel and carbon steel

5. Installation Methods for the Saw Blade

1. Checking the saw blade and welding coupling before installation
2. Up rise the saw frame to 1-1.1m height, and open the front cover, follow the marks instruction (loosen and clamp) to rotate up the lead screw 5-7cm, loosen right and left landing legs' screws, make sure 3-5mm distance between two clamping blocks
3. Install blade onto two wheels and guiding box, keep blade back close to blade back bearing, rotate valve to tension blade. The clamping force of blade was normally about 25-35N.M. Too high feed rate and cutting speed with strong impact force between blade and work-piece may cause blade broken
4. Power on and off and make the blade rotating gradually for 3 rounds, till the saw blade into normal working
5. Keeping the machine into free working for 2-3 minutes for checking without any abnormal happened

6. Fixture Stock

See the Figure 1 for the clamping of variable stocks

Fixture methods for stocks with variable shapes							
Shape	1 Piece	2 Piece	3 Piece	4 Piece	5 Piece	6 Piece	Multiple pieces
Round bar Pipe profile							
Hexagonal bar							
Square tube							
Angle steel							
U steel							
H steel							
C steel							
Rail steel							

Figure 1

7. Hydraulic System

The hydraulic system was used for:

- (1) Up and down of saw frame
- (2) Clamping and unclamping of stock
- (3) Blade feeding speed, system pressure:1.8-2.0Mpa

No.	Model	Name	QTY	Remark
1	WU25-100	Filter	1	
2	YBI-6.3	Gear pump	1	6.3 liter
3	YT-90J	Motor	1	0.75kw/1440rpm
4	P-B10B	Overflow valve	1	
5	DSG-032-3C2-24V	Electrical-magnetic valve (3 positions;4-way)	1	
6	HDJ-10Y	Throttle Valves	1	
7	22C-10	Stroke valve (2 positions,2 way)	1	
8	340-10	Selector valve (3 positions,4 ways)	1	

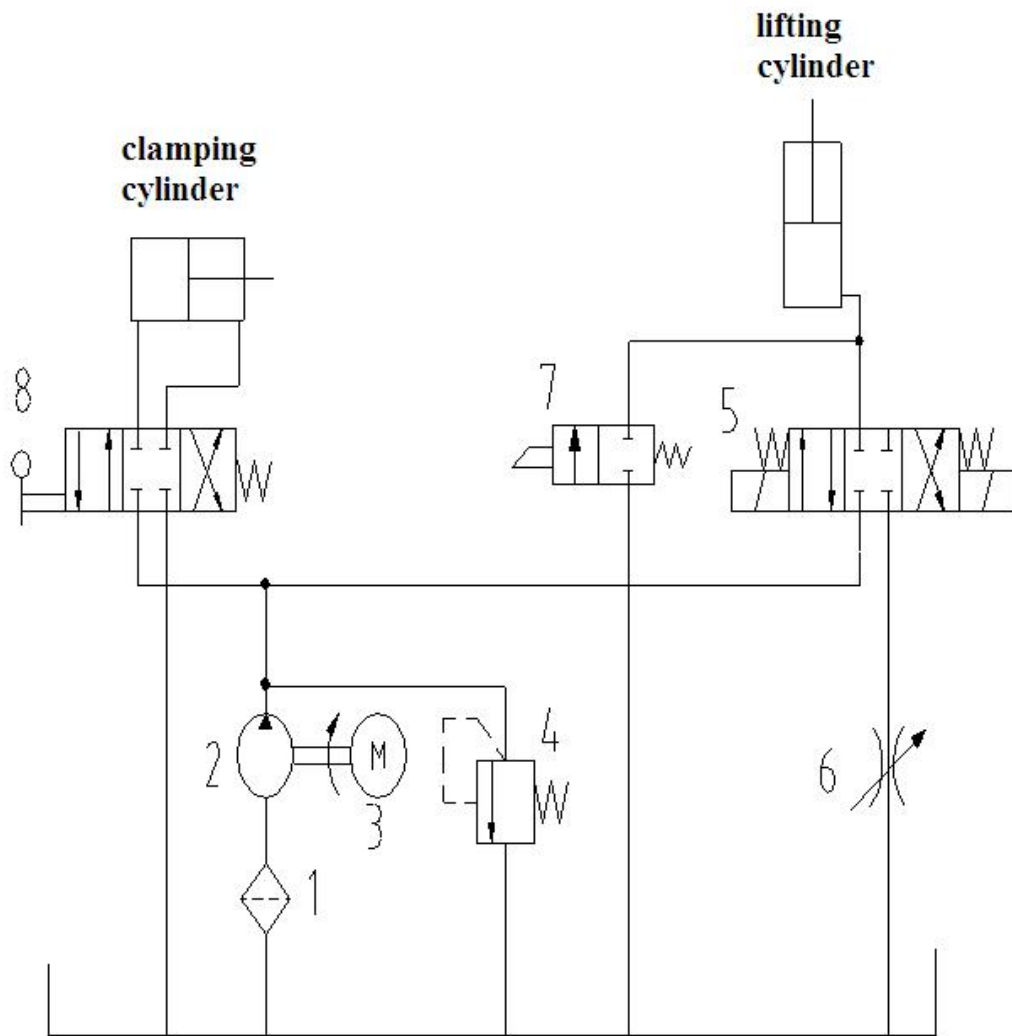

Hydraulic Schematic

8. Electrical Principle Chart

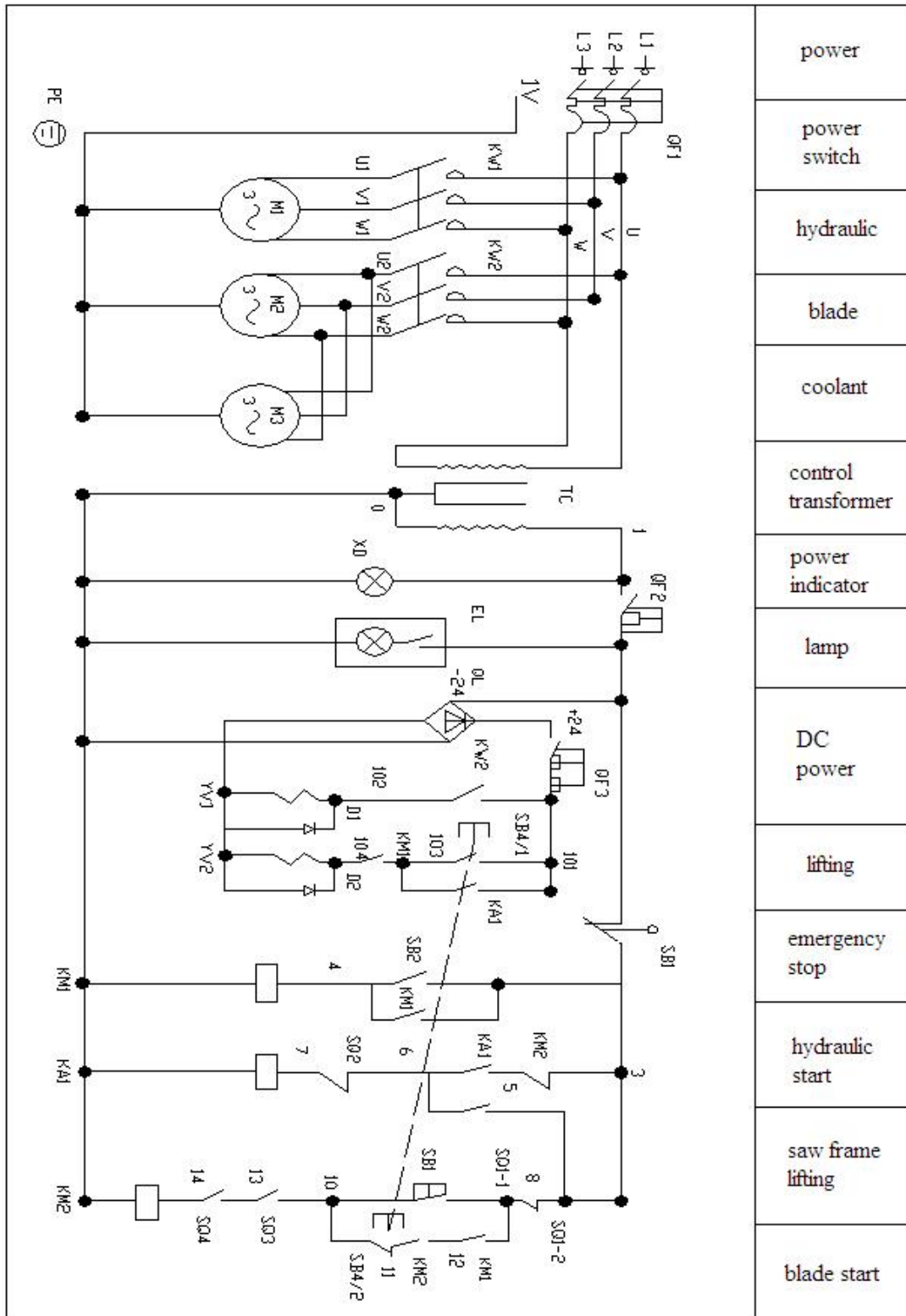

power
power switch
hydraulic
blade
coolant
control transformer
power indicator
lamp
DC power
lifting
emergency stop
hydraulic start
saw frame lifting
blade start

9. Operation and Maintenance

1. Checking the power source with correct wire connecting and keep the suitable coolant liquid and hydraulic oil
2. Idle running machine and assure the machine with right rotating direction and fluent coolant and moving of up and down
3. Adjusting the stock stopper with right position of cutting length, and stock is in clamping status
4. Keeping the stock bracket at suitable height
5. Adjusting the up-valve and down-valve and make the saw blade 2cm higher than the stock, and adjust the stroke quill and make sure that the stroke switch can be touched properly during up rising and cutting off of saw blade
6. Lubrication oil should be changed periodically
7. Lubrication oil No.32 was applicable for the sliding parts, such as clamping vise, main column, sub-column
8. Any parts of the personal body should be away from the running blade
9. Overload operation will cause a hard damage to the machine
10. Blade changing should be operated after power off
11. Keep clean environment around the machine
12. Power off the main switch while stopping the machine and rise-up the bracing, opening the vise and saw blade

10. Usual Major Faults And Solution

10.1 Mechanical parts

Faults	Main reason caused	Solution
Teeth broken	High feeding rate	Decrease the feeding rate
	Oversize teeth selected	Change blade with smaller teeth
	Wrong fixture of irregular stock	Revise the fixture
	No match up of blade	Test blade firstly
Teeth tip wear off	High speed rotating of saw blade	Lower speed
	Higher hardness of material	Change the saw blade into high hardness
	Cutting coolant liquid density	Increase the density
	Wrong coolant liquid chosen	Change the coolant liquid number
	Higher feeding rate	Lower the feeding speed
Harsh Section of saw blade	Higher feeding rate	Lower the feeding speed
	Wrong coolant chosen	Choose the suitable coolant
	Unqualified saw blade	Change the blade
Sharp sound while cutting	Over speed of saw blade	Decrease the speed
	Irregular surface of welding joint	Grind the welding joint
	Wrong coolant chosen	Change the coolant
	Tolerance between leading box and saw blade	Adjust the tolerance again
	Over feeding rate and higher pressure	Lower the feeding speed

Faults	Main reason caused	Solution
Geometrical accuracy out of tolerance	Low tension of saw blade	Decrease the saw speed
	Split teeth or lower symmetry	Change new saw blade
	Far distance between leading bracket and stock	Adjust the distance less than 3cm
	Teeth wear out	Change saw blade
	Un-perpendicular between saw blade and vise	Adjust leading box
Saw blade drop off	Low tension of saw blade	Tension the saw blade
	Unbalance driven wheel and driving wheel	Adjust the tension nuts
Noise of reducer box	Bearing broken inside	Change bearing
	Abrasion inner hole with the shaft	Change the driving wheel
	Wheel abrasion and reducer damage	Change the wheel
	Abrasion of worm bar and worm gear	Change the bar or gear
	Out of oil in the reducer box	Oil charging
No manual up rising or auto-rising of saw frame and	Low pressure	Adjust the relief valve
	Oil route blocking or leaking	Clean or change the valve, filter, bracing the joint
	Stroke switch out of service	Repair or change the switch
	Wiring failure	Check the wire diagram
No descending or even descending of saw frame	Speed-adjust valve blocking	Clean or change the valve
	Descending valve out of work	Check the oil route
	High back-pressure	Adjust the pressure
	Valve's core locking inside	Clean the core of valve

Faults	Main reason caused	Solution
	Un-vacuum oil cylinder	Discharge the air

10.2 Electrical parts

Faults	Main reason caused	Solution
No power supply and oil pump does not work once turning on the main switch	Power source no connecting	Connect the power
	Short cut electricity	Repair or change the breaker
	Open the emergency stop button	Reset the stop button
Machine still work when pushing the stop button	Button broken	Change the button
	Wiring failure	Check the wire diagram
machine does not work when pushing the start button	Button for saw blade broken	Repair or change the button
	Wiring failure	Check the wire diagram
	Stroke switch out of work	Repair or Change he switch
Machine still work after cutting off stock	Limit switch out of work	Repair or change the switch
	Limit nut not in right position	Adjust the nut into right position
Indicator out of work	Transformer broken	Repair or change the transformer
	Indicator broken	change the indicator

10.3 Hydraulic parts

Faults	Main reason caused	Solution
No Oil pumping	Filter blocking	Clean or change the filter
	Low oil level, should be 2-3cm higher	Add hydraulic oil
	High oil viscosity	Change the oil
Oil foaming	Low air exhausting	Reciprocate moving up and down of saw frame and exhaust the air extremely
	Oil leaking	Brace the coupling
	Seals leaking of oil pump shaft	Change the sealing ring
	Oil return pipe above oil surface	Submerge the oil tube
	Oil pump wear out or broken	Change the pump
Wrong rotating direction of oil pump	Incorrect wiring connecting	Check the wire diagram
High oil temperature	Oil pump wear out or broken	Repair or change pump
	Low oil viscosity	Change oil
	High oil pressure	Adjust the pressure
Saw frame auto descending at middle level	Over tolerance between the core of selector valve and valve hole	Repair or change selector valve
	Sealing ring broken of oil cylinder	Repair or change the sealing ring
	Speed-adjusting valve open	Close the valve

11. Precautions

1. Please read the manual books carefully and get to know this machine before operating
2. Balancing the machine after installation
3. Clean oil cylinder before adding oil, clean 32# oil is best choice, but 46# oil is required if environment temperature above 30°C
4. Ground wiring should be wiring at least 50cm below the ground
5. Power voltages should be controlled at the range of $\pm 10\%$ of machine voltage, in case of damaging the electrical components

12. Packing List

No.	Name	Qty	Remark
1	Bi-metal saw blade	1 piece	
2	Roller rack	1 set	
3	Tool box	1 set	
4	Manual book	1 copy	