

HAND NOTCHER

MODEL: HN-3/102

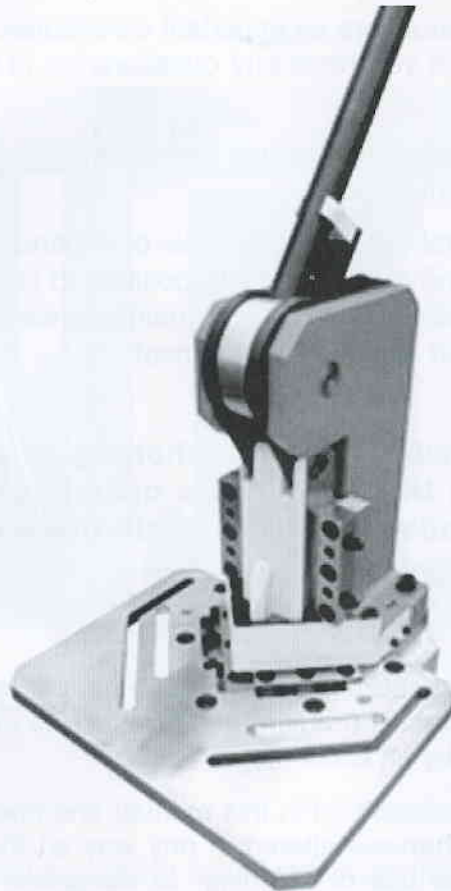

OPERATION MANUAL

I . INFORMATION

The manual contains information on the safe and proper installation, operation and maintenance of the plant. The strict observance of all instructions contained in this manual to ensure the safety of people and the machine.

The manual sets out the purpose for which the machine and contains all the information needed for their efficient operation and a long service life of the machine.

Maintenance section all maintenance and functional tests are described that must be executed by the user on a regular basis.

In this manual or existing images and information offered may differ from the current structural condition of your machine. The manufacturer is constantly striving to improve and renew the products; therefore, optical and technical changes are made without these be communicated. Changes and errors without prior notice.

Your suggestions regarding this manual are an important contribution to the optimization of our work that we offer our customers. If you have any questions or, in the case of proposals for improvement to our service.

The term "Machine" is replaced below the normal trade description of the item on, which this manual applies (see front page) .

When the term "expert" is personnel, which is the basis of experience, his technical qualifications and knowledge of the laws and regulations in a position to carry out the necessary work and the operation, during installation, the use and maintenance of the machine recognize potentially dangerous situations and avoid from the outset.

Note:

Before installation, please read this manual thoroughly and familiarize yourself with the device. Also ensure that all persons operating the equipment, always have previously read and understood. Keep this manual carefully to the area around the machine.

II . INTENDED USE

The machine is for the notching of sheets. The disengagement is carried out in a right angle (90 °). It is a working engine by hand. The cutting performance is achieved by a mechanical implementation of the manual force by an eccentric.

The machine must be used only as described in this manual and operated. The machine may not be subsequently modified or otherwise altered in any way so that originally lose existing protection devices effective. Another use of notching, as described for the specified normal purpose is not allowed.

Caution:

The non-conforming use of the machine as well as the disregard of the safety of the user or the manufacturer from liability for any resulting damage to persons or property and will result in loss of warranty claim!

Caution:

Before use, maintenance or other operations on the machine, the operating and maintenance instructions are read and understood. The handling and the operation of the machine is only available to persons who are with the mode of operation and handling of the machine thoroughly familiar!

III. SPECIFICATIONS

MODEL	HN-3/102
Thickness	3 mm
Punches	100x100mm
90°Angle	100x100mm
Ram stroke	30mm
Packing size	46x45x76cm
N.G./G.W.	90/105kgs

* Stated on plates with a tensile strength of 400 N/mm²

IV. Parts Position

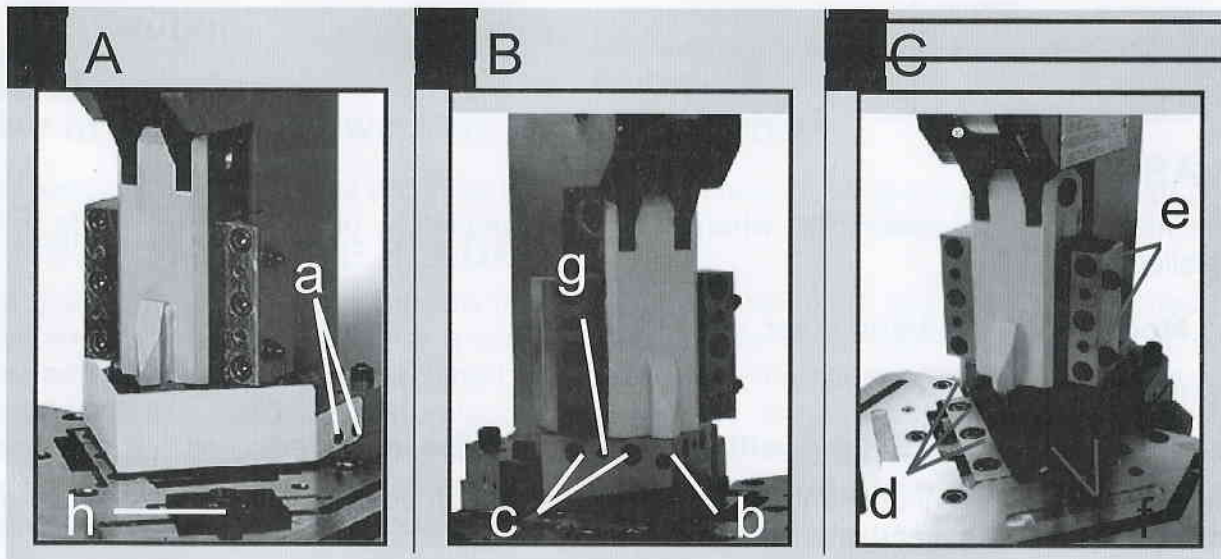

V. UNPACKING AND OPERATION

1. CLEANING

To prevent corrosion on all blank parts of the machine in the factory protective waxes and protective fats were applied. Clean the machine before first use with a suitable, environmentally friendly cleaning agent (we recommend to clean petroleum!). When cleaning solvents, nitro-dilution or other cleaning agents that might damage the paint of the machine. Note the information and advice of the detergent manufacturer. Ensure good ventilation during the cleaning work, to avoid health risks from toxic fumes.

After the engine has been thoroughly cleaned, all bare machine parts should be lightly oiled. Use an acid-free lubricants and anti-corrosion oil.

2. WORKSPACE

Mount the machine to a suitable site on the floor or a suitable base. Make sure that you have enough space around the machine. Screw the machine firmly to the ground before you use them.

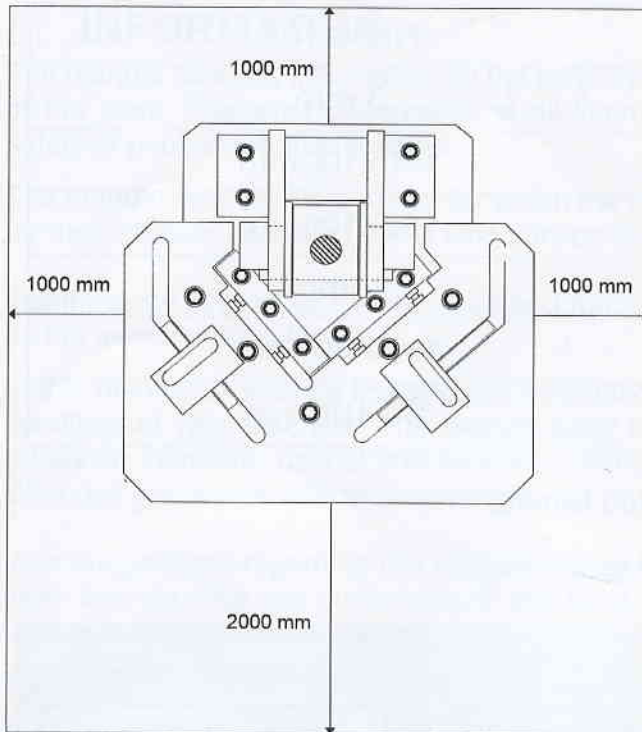

3. ASSEMBLY

The machine is pre-assembled when delivered completely, only the lever needs to be installed.

3.1 Mounting of the hand lever

Danger!

Secure the lever in the up position always with the intended

Plastic clamp to prevent unintentional folding of the lever. Inadvertent flap lever can a heavy blow to cause external and internal injuries.

Screw the two parts of the handle together, then screw the hand lever in the dedicated thread in the eccentric. With the plastic clamping the lever can be fixed in the upper position. Press the lever to the clamp until it clicks. The lever is secured against accidental valve.

3.2 REPLACING THE UPPER KNIFE

3.2.1 Remove the protective cover. Loosen the hex screws [a] on the left and right side and remove the cover.

3.2.2 To remove the blade first loosen the screw [b] and then the screws [c].

3.2.3 Pull the knife away evenly from dowel pin [g]. Make sure that the blade do not pull straight!

3.2.4 To fit the new blade, proceed in reverse order.

3.3 REPLACING THE LOWER BLADE

3.3.1 Remove the protective cover. Loosen the hex screws [a] on the left and right side and remove the cover.

3.3.2 To remove the lower blade, loosen the screws [d]. The blade can then be removed upwardly. Attention! The screws [f] can be reused when replacing the blades.

3.3.3 Install the new bottom blade and tighten the screws as much as possible in the Knife, so when you shut down the punch top and bottom blade do not knock against each other.

3.3.4 Turn the screws [d] all the way into the thread and tighten.

3.4 SETTING THE CUTTING GAP

Take the plunger all the way down. Make sure that the upper and lower blade does not knock against each other.

3.4.1 Re-open the screws [d] a quarter turn.

3.4.2 With the aid of the adjusting screws under cutter can now be moved smoothly to the outer cutter. Take the lower blade to the stop closer to the upper blade. Adjust place by opening the screws enter the desired gap.

3.4.3 If the required clearance set, screw the blade firmly with the screws [d]. Make sure that the head of the screws present at the work table.

3.4.4 Secure the screws by tightening the lock nuts on the screws [f].

3.4.5 Perform the first test cut with a paper. Are the edges evenly, the knives are set correctly. Also check the squareness of the cut sample and adjust according to the description.

4. NOTCHING SHEET



Caution!

Risk of injury when working with the machine.

The machine is intended for notching and cutting of sheets having a fixed angle of 90 °.

5. HOW TO CHANGE BLADES

The blades of the hand notcher are made of surface-hardened tool steel. The blades do wear and must be replaced after a certain time. The life of the blades depends on criteria such as the materials of the machined workpieces, and the correct cutting gap adjustment. To achieve the specified performance, the average properties of the material to be processed are crucial. Reaching the cutting capacity - at the same time perfect cutting edges - requires the use of sharp original metal blades or power-original metal power replacement blades, and an accurate adjustment of the gap.

6. USE OF THE MATERIAL STOPS

Attacks the material used in order to achieve for several notches and workpieces the exact same dimensions. With the help of the work table attached scale, the dimensions can be adjusted easily and quickly.

6.1 Loosen the nut [h].

6.2 Bring the material stops in the desired position.

6.3 Secure the material stop with the nut [h].

Examples of settings for the material stops

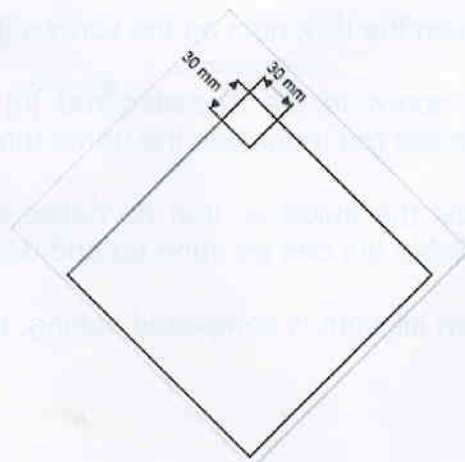
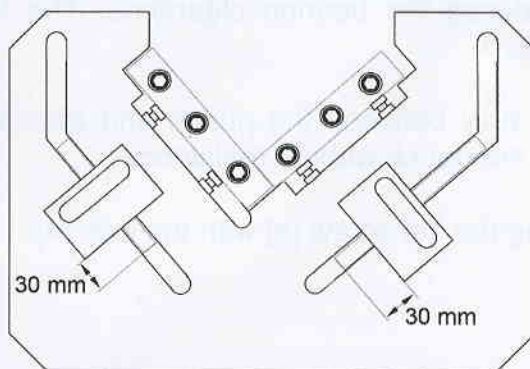

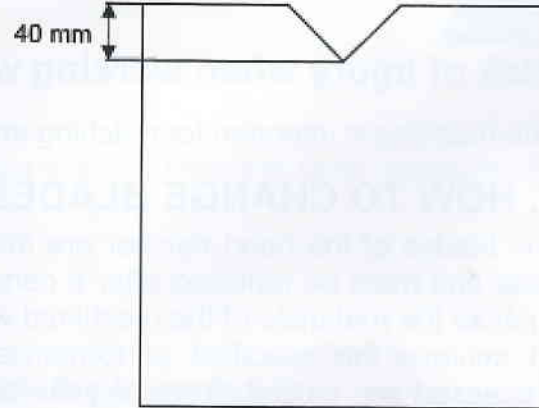
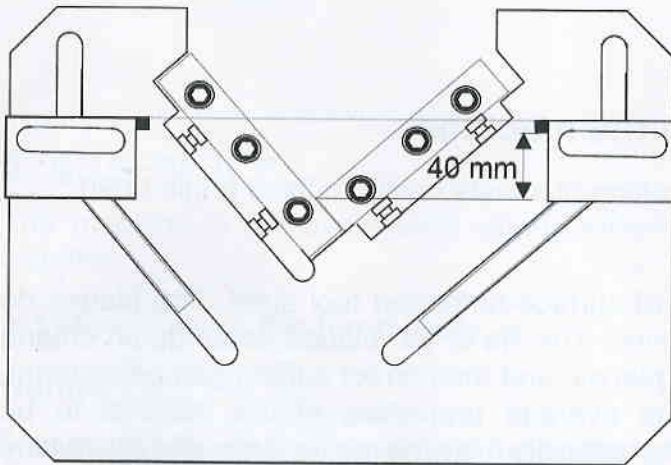
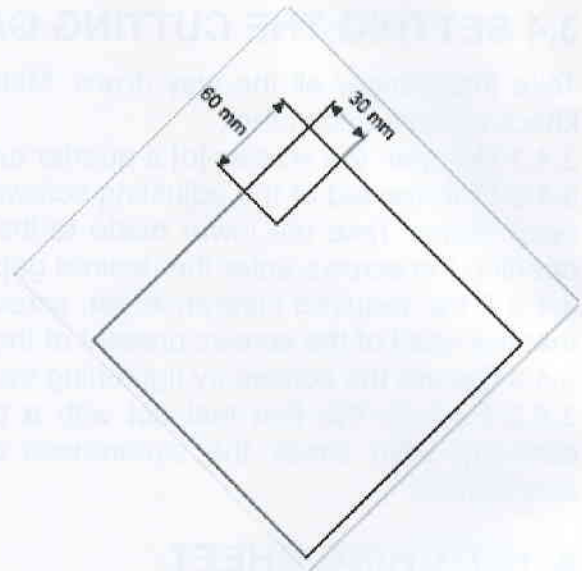
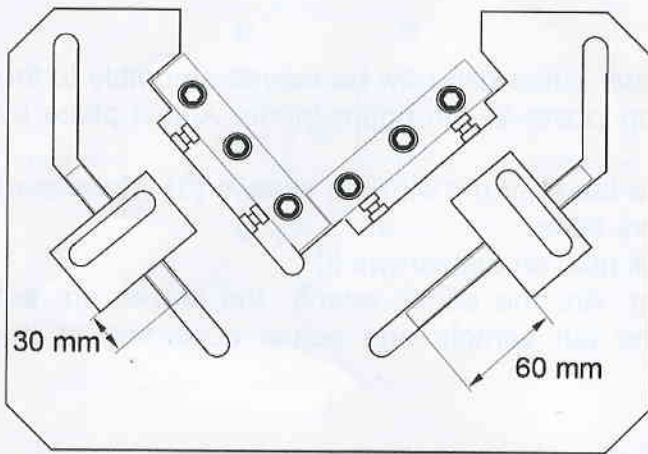

VI. MAINTENANCE

After work, or at least once a week, the machine should be cleaned and greased the bearing seats and work surfaces to be lubricated.

VII. ADJUSTING THE PUNCH GUIDE

Loosen the lock nuts on the screws [h].

The screw in the threaded rod [h] reduces the bearing clearance. The turning of the threaded rod magnifies the game thread.

Adjust the guide so that no noticeable play between the punch and slide the bearing is available but can be done up and down the punch without resistance.

When all work is completed setting, fixing the set screw [h] with the lock nut.

VIII. Exploded drawing & Parts list

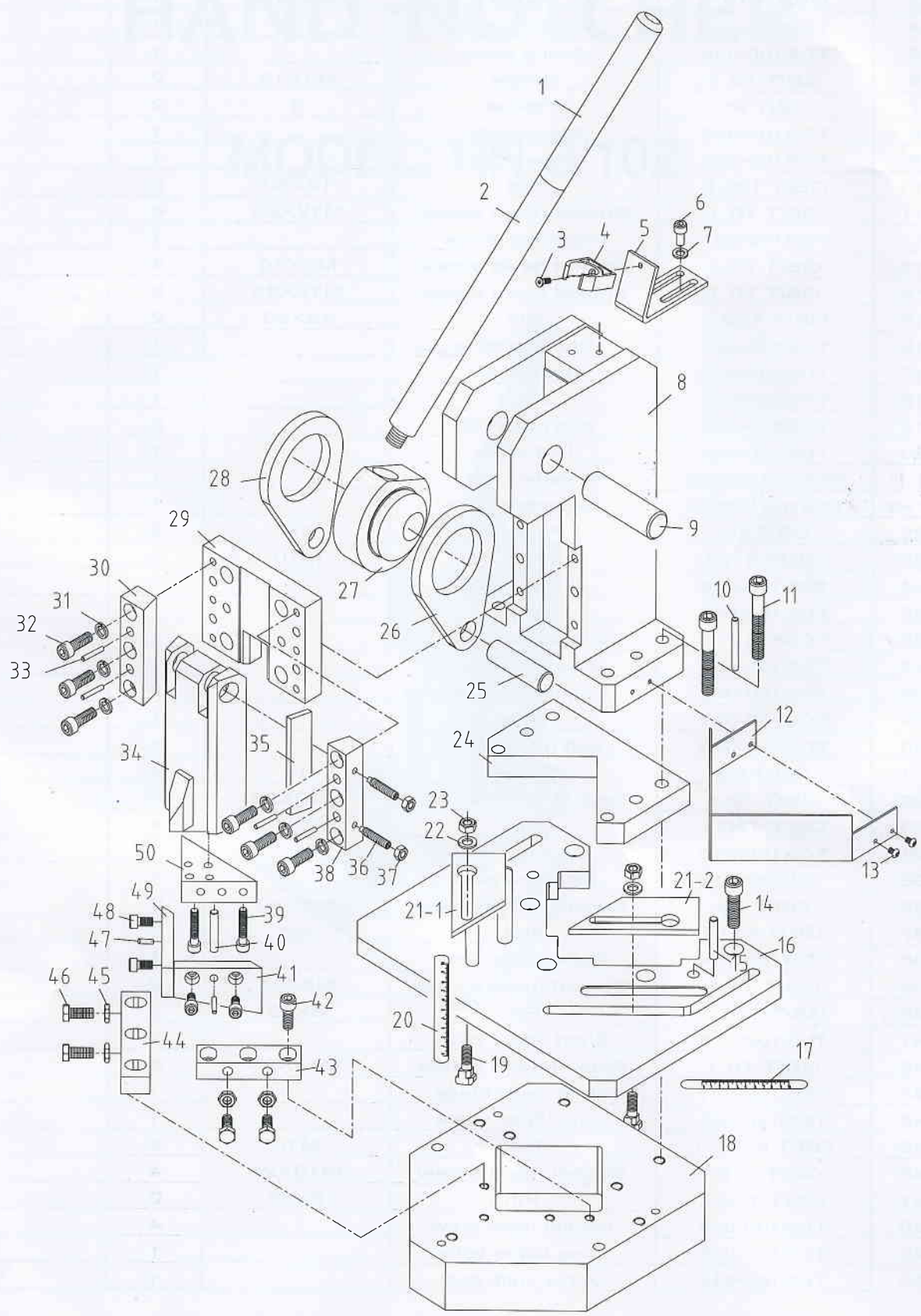

NO.	ITEM #	DESC	Specification	QTY	Remarks
1	TCS100-001	Enlarger handle		1	
2	TCS100-002	Handle		1	
3	GB/T 819.1	Screw	M5X16	1	
4	TCS100-003	Plastic clamp		1	
5	TCS100-004	Fixing plate		1	
6	GB/T 70.1	Screw	M8X16	2	
7	GB/T 95	Washer	8	2	
8	TCS100-005	Stand body		1	
9	TCS100-007	Main shaft		1	
10	GB/T 120.2	Pin	12X80	2	
11	GB/T 70.1	Socket head screw	M12X80	4	
12	TCS100-027	Protection cover		1	
13	GB/T 70.2	Socket head screw	M5X10	4	
14	GB/T 70.1	Socket head screw	M12X35	5	
15	GB/T 120.2	Pin	12X50	2	
16	TCS100-020	Working table		1	
17	TCS100-023	Right scale		1	
18	TCS100-019	Base		1	
19	TCS100-026	Flat head bolt		2	
20	TCS100-024	Left scale		1	
21--1	TCS100-025-02	Material stop 1		1	
21--2	TCS100-025-01	Material stop 2		1	
22	GB/T 95	Washer	10	2	
23	GB/T 6170	Nut	M10	2	
24	TCS100-018	Fixing plate		1	
25	TCS100-009	Shaft		1	
26	TCS100-008	Connection plate		2	
27	TCS100-006	Eccentric shaft		1	
28	TCS100-008	Connection plate		2	
29	TCS100-011	Plate		1	
30	TCS100-013	Left guide plate		1	
31	GB/T 93	Washer	10	4	
32	GB/T 70.1	Socket head screw	M10X30	6	
33	GB/T 120.2	Pin	10X40	4	
34	TCS100-010	Sliding plate		1	
35	TCS100-015	adjusting plate		1	
36	GB/T 79	Socket head screw	M8X40	2	
37	GB/T 6170	Nut	M8	2	
38	TCS100-014	Right guide plate		1	
39	GB/T 70.1	Socket head screw	M8X35	2	
40	GB/T 120.2	Pin	8X45	2	
41	TCS100-016	Short upper knife		1	
42	GB/T 70.1	Socket head screw	M10X25	6	
43	TCS100-021	Short lower blade		1	
44	TCS100-022	Long lower blade		1	
45	GB/T 6172.1	Nut	M10	4	
46	GB/T 5783	Socket head screw	M10X25	4	
47	GB/T 120.2	Pin	8X30	2	
48	TCS100-028	Socket head crew		4	
49	TCS100-017	Long upper knife		1	
50	TCS100-012	Upper knife seat		1	

Note: This manual is only for your reference. Owing to the continuous improvement of the machine, changes may be made at any time without obligation on notice. And please note the local voltage while operating this electric machine.