

20W Portable Rechargeable LED Work Light

Please read this guide thoroughly before use and retain for future reference.

Safety Information

- The work light is IP65 and IK08 rated and suitable for outdoor use but must be charged in a cool and dry location.
- **Do not** use the charger if the cable is damaged.
- **Do not** charge the internal battery pack with any charger other than the one supplied.
- **Do not** cover the charger while charging.
- **Do not** use a damaged battery or work light. If damaged, liquid or vapour may leak from the battery or work light and cause irritation or burns. Ventilate against fumes. If contact accidentally occurs, flush with water. If liquid contacts eyes, seek immediate medical help.
- **Do not** tamper with the battery pack or wiring.
- **Do not** open the battery pack. Damage may cause short-circuit, fire or burns.
- **Do not** put the battery or work light in household waste. Observe the notes for disposal.
- **Do not** put the battery or work light in water or fire and protect from intense heat or the battery or work light may cause burning or explode.
- The battery pack is protected against overcharging, deep discharging, short-circuit and over-current.
- The battery pack should only be charged in an ambient temperature of 0°C to 40°C.
- The work light should only be used in an ambient temperature of -10°C to 40°C.
- Apply a half charge if storing for a long period.
- Do not clean the work light with solvents. Use a mild soap solution if necessary and thoroughly dry before use with a soft, clean, dry cloth.
- Store in a clean dry area.

Charging Instructions

- Charge the work light before first use. The Li-ion battery will accept a partial charge, but a full charge will take 5.5 hours.
- The work light should be turned off during charging as this is better for the battery. If it must be used during charging, use it on the lowest light setting.
- Insert the transformer's jack plug into the charging input socket on the side of the work light. The socket is covered by a small rubber dust cap which must be replaced after charging.
- It is normal for the charger and the battery to become warm while charging. Disconnect if the battery or charger feels excessively warm.
- The charger shows a red LED during charging that changes to green when charging is complete.
- When finished charging, unplug the charger from the mains supply and from the work light, then replace the rubber dust cap.

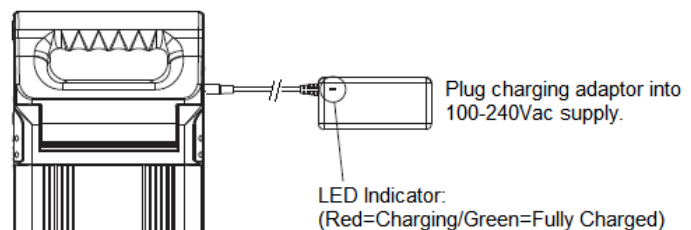

Stand for Work Light

A stand is available for the 20W work light and can be connected as shown:

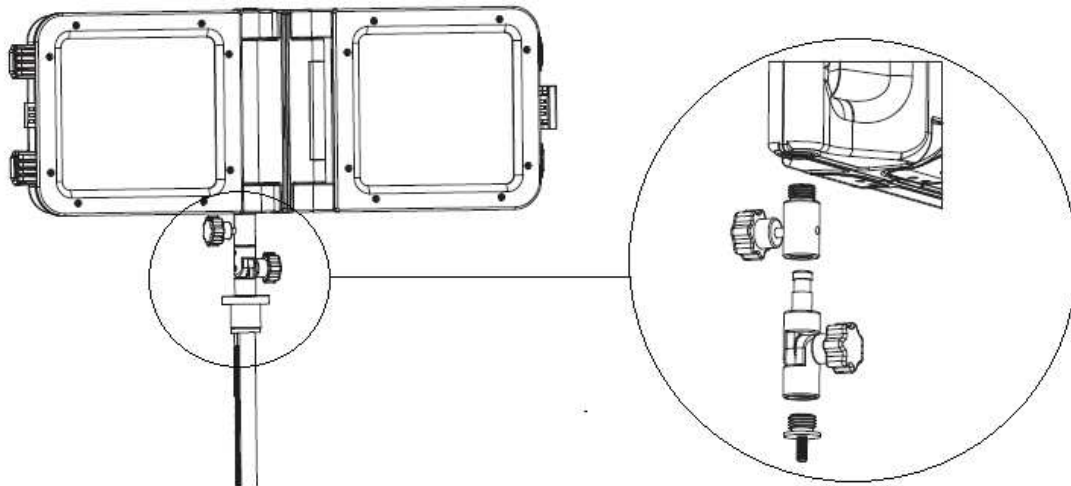

Operating Instructions

- The work light should be disconnected from the charger and the dust cover replaced on the input socket.
- Open the work light and site as necessary. A stand is available for the 20W work light.
- Turn the work light on and off using the small push button switch next to the charging input.
- Repeated pressing of the button will cycle the work light through 3 light levels; 30%, 100%, single side 50%, OFF.
- The work light will operate for the following time: 100% = 3.4 hours, 50% = 6.5 hours, 30% = 10 hours.

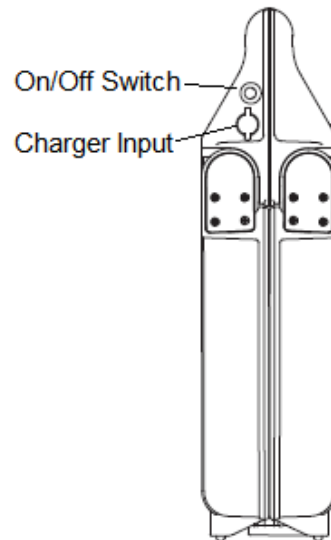

End of Life Battery Removal

The battery in this work light is not intended to be replaced but can be removed before recycling:

- Disconnect the work light from the charger and mains supply.
- Locate the battery compartment cover on the centre section of the work light.
- Remove the four screws and lift off the cover.
- Disconnect the battery and dispose of at a suitable recycling centre.

Disposal

- Do not dispose of the battery pack or work light into household waste. At the end of its service life the battery pack and work light should be disposed of at a local collection point for the recycling of electrical and electronic equipment.
- Battery packs should be discharged and recycled or disposed of separately and in an environmental-friendly manner. In the EU, defective or used batteries must be recycled according the guideline 2006/66/EC.

