

Pan& Box Brake

Model: W2.0X2040A/W2.5x2040A

W2.0X2540A/W2.5x2540A/W2.0X3050A



Assembly & Operating Instructions

Description and Specifications

Model: 2.0X2040A/W2.5x2040A/W2.0X2540A/W2.5x2540A/ W2.0X3050A Pan & Box Brakes are hand operated machine with removable dies and a 101.6mm shut height allowing it to fabricate pans, boxes, channels, angles and other shapes. Adjustable counterweights allow the operator to balance the bending leaf to correspond to work piece thickness. An adjustable stop gauge is included to allow the operator to perform repeat bends.

Model	Capacity (Mild steel)			Male die sizes (mm)	Shut height (mm)	Packing Dimensions (cm)	Weight (kgs)
	Max. Width	Max. thickness	Angle				
W2.0x2040A	2040 mm	2.0mm 14 gauage	0-135°	76,104,127, 153,280	101.6	250x77x110	850/100 0
W2.5x2040A	2040 mm	2.5mm 12 gauage	0-135°	76,104,127, 153,280	101.6	250x77x110	1145/12 95
W2.0x2540A	2540 mm	2.0mm 14 gauage	0-135°	<u>63,76,89,102,127</u> <u>,152,305</u>	101.6	300x77x110	1190/13 60
W2.5x2540A	2540 mm	2.5mm 12 gauage	0-135°	<u>63,76,89,102,127</u> <u>,152,305</u>	101.6	300x77x110	1310/14 80
W2.0x3050A	3050 mm	2.0mm 14 gauage	0-135°	<u>76,127,153,254,</u> <u>305</u>	101.6	350x77x110	1490/16 90

Unpacking

Refer to Figure 1.

Check for shipping damage. If damage has occurred, a claim must be filed with carrier. Check for completeness. Please immediately report missing parts to dealer. Carefully open crate and unbolt brake from shipping pallet and remove from crate using heavy duty lifting equipment such as an overhead crane.

Warning

Be careful not to touch overhead power lines, piping, lighting, etc if lifting equipment is used. Proper tools, equipment and qualified personnel should be employed in all phases of unpacking and installation.

The brake comes assembled as one unit. Additional parts which need to be fastened to the tool should be located and accounted for before assembling:

A. Supports, 2 each

- B. Operation handle, 1 each
- C. Stop gauge assembly
- D. Counterweight assembly, 2 each

Figure 1-unpacking

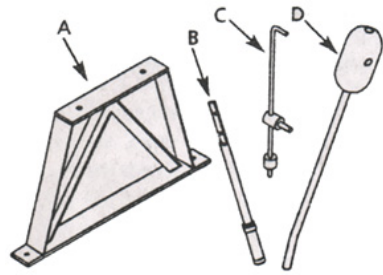

Hardware bag includes: eight 12-1.5 x 40mm hex bolts, eight 16/12mm flat washers, eight 10mm lock four 12-1.5 X 20mm hex nuts and five cotter pins.

head washers,

Important: Dies are coated with a protectant. To ensure proper fit and operation, remove coating. Coating is easily removed with mild solvents, such as mineral spirits, and a soft cloth. Avoid getting cleaning solution on paint or any of the rubber or plastic parts.

Solvents may deteriorate these finishes. Use soap and water on paint, plastic or rubber components. After cleaning, cover all exposed surfaces with a light coating of oil. Paste wax is recommended for table top.

⚠ Warning

Never use highly volatile solvents. Non-flammable solvents are recommended to avoid possible fire hazard.

General Safety Information

⚠ Warning

For your own safety, read all of the instruction and precautions before operation tool.

⚠ Caution

Always follow proper operating procedures as defined in this manual even if you are familiar with use of this or similar tools. Remember that being careless for even a fraction of a second can result in severe personal injury.

Be prepare for job

1. Wear proper apparel. Do not wear loose clothing, gloves, neckties, rings, bracelets or other jewelry which may get caught in moving parts of machine.
2. Wear protective hair covering to contain long hair.
3. Wear safety shoes with non-slip soles.
4. Wear safety glasses complying with United States ANSI Z87.1. Everyday glasses have only impact resistant lenses. They are **NOT** safety glasses.
5. Be alert and think clearly, Never operate tools when tired, intoxicated or when taking medications that cause drowsiness.

PREPARE WORK AREA FOR JOB

1. Keep work area clean. Cluttered work areas invite accidents.
2. Work area should be properly lighted.

3. Keep visitors at a safe distance from work area.
4. Keep children out of workplace. Make workshop childproof. Use padlocks to prevent any unintentional use of tools.

TOOL SHOULD BE MAINTAINED

1. Consult manual for specific maintaining and adjusting procedures.
2. Keep tool lubricated and clean for safety operation.
3. Remove adjusting tools. Form habit of checking to see that adjusting tools are removed before using machine.
4. Keep all parts in working order. Check to determine that the guard or other parts will operate properly and perform their intended function.
5. Check for damaged parts. Check for alignment of moving parts, binding, breakage, and, mounting or any other condition that may affect a tool's operation.
6. A guard or other damaged part should be properly repaired or replaced. Do not perform makeshift repairs. (Use parts list provided to order repair parts.)

KNOW HOW TO USE TOOL

1. Use right tool for job. Do not force tool or attachment to do a job for which it was not designed.
2. Keep hands and clothing clear of brake nip joints.
3. The maximum capacity if this machine is 14gauge (0.070") mild steel or equivalent. Exceeding capacity may be dangerous to operator and cause damage to machine.
4. Bolt machine to floor to prevent sliding or tipping of machine.
5. Keep bystanders away from area of counterweight movement.
6. Do not attempt to bend round bars-damaged to machine will occur.
7. Work piece must have square-sheared edges. Rolled edges will cause work piece to bow.

Assembly

Refer to Figure 2 and 3.

MOUNT BEAM TO SUPPORTS

Refer to Figure 2.

Lift beam, (Ref. No. 36) with appropriate hoisting equipment and secure supports (Ref.No.40.) to beam with bolts, nuts and washers (Ref. Nos.17, 24, 30, and 43)

Warning

Be careful not to touch overhead power lines, piping, lighting, etc. if lifting equipment is used. Brake weighs approximately 2000 kg. Proper tools, equipment and qualified personal should be employed in all phases of unpacking and installation.

ATTACH CLAMPING HANDLES AND LINKS TO CLAMPING LEAF

Refer to Figure2.

Remove spacer, spring, hex head bolt and washer (Ref. Nos.1, 2, 3 and 24) from left side of the clamping leaf (Ref. No. 7). Loosen hex nuts (Ref. No.29) on the link (Ref. No.6). Insert the pivot block (Ref. No.31) of link into the hole in the beam (Ref. No. 36) and secure with cotter pin (Ref. No.42). Mount the clamping handles (Ref. Nos. 4 and 9) over the pin (Ref. No. 8) with bearing

surface of handle inside link. The counterweight on the handle faces away from the operator (See Figure 2). Place spring, spacer and washer over pin and secure with hex head bolt. Repeat for right side of machine.

MOUNT OPERATING HANDLE TO BENDING LEAF

Refer to Figure 3.

Mount operating handles (Ref. No. 61) to the bending leaf (Ref.No.64) with hex head bolts and washers (Ref. Nos. 60, 65 and 66).

MOUNT COUNTERWEIGHT TO BENDING LEAF

Refer to Figure 3.

Insert the counterweight assemblies (Ref. Nos. 51, 52 and 53) into the hinges (Ref. Nos. 58 and 70) and secure with set screws (Ref. No.56). The counterweight are positioned near the bending leaf for thin work piece, further from leaf for thick work pieces.

MOUNT STOP GUAGE ASSEMBLY

Refer to Figure 2 and 3.

Insert pivot shaft (Figure 2, Ref. No.38) into hole on left side of beam (Figure 2, Ref. No. 36) and secure in position with cotter pin (Figure 2, Ref. No. 42). Slide end of guide rod (Figure 2, Ref. No.37) into the pivot shaft and also into the sleeve on the side of the left hinge (Figure3, Ref. No. 70) and secure with cotter pin. Install collar (Figure 2, Ref. No. 39) onto guide rod and secure in position with set screw (Figure 2, Ref. No. 44). Install cotter pin on the guide rod to retain collar.

INSTALLATION

Machine should be install on a level surface with proper lighting. Use four mounting holes on left and right supports to bolt machine securely to floor (fasteners not included). Area around machine should be clear of scraps, oil or dirt. Apply a suitable non-skid material to floor. Allow approximately three feet clearance on all side of the brake for ease of operation.

Operation

Refer to Figures 2 and 3.

The maximum capacity of the machine is 14 gauge (0.070") mild steel or equivalent. Below is an equivalency chart for use when working with materials other than mild steel:

	EQUIVALENCY CHART	
Mild steel	2.0 mm	2.5 mm
Stainless steel	1.2mm	1.5 mm
SAE 1050 cold-rolled steel	1.2mm	1.5 mm
Aluminum	3.0 mm	4.0 mm
Soft brass	2.2 mm	2.7mm
Annealed phosphor bronze	2.0 mm	2.4 mm
Soft copper	2.2 mm	2.7 mm
Hard copper	2.0 mm	2.4 mm
ABS plastic	4.0 mm	5.0 mm

1. When the bending leaf (Figure 3, Ref.No.64) is at the bottom dead center position, the edge of the bending leaf must be flush with the beam edge. To adjust, loosen socket head bolts (Figure 3, Ref. No.59), turn hex head bolts (Figure 3, Ref. No. 57) as needed, and retighten the mounting bolts. If the leaf has been adjusted flush on both ends, but is not flush in the center, adjust nuts located in the center of the beam and bending leaf until center is aligned.
2. Adjust the clamping leaf (Figure 2, Ref. No. 7) to the work piece thickness. Pull both clamping handles (Figure 2, Ref. Nos. 4 and 9) forward and loosen lower hex nuts (Figure 2, Ref. No. 29) so that the clamping leaf rests on the beam (Figure 2, Ref. No. 36), but is not under pressure. Rotate hand wheels (Figure 2, Ref. No. 35) so that the front edge of the nose on the clamping leaf is set back from the beam edge equal to the thickness of the work piece. Minimum distance is work piece thickness. Clamping leaf can be set further away from table edge to produce a larger radius bend. Make sure to adjust the hand wheels equally, so that the clamping leaf edge is parallel to the beam edge. The lower hex nuts will be tightened after the next step.
3. Adjust the clamping pressure. Place sample of the work piece on the table and move the clamping handles forward. Work piece should be held firmly in position. To adjust for more or less pressure, unclamp the work piece and adjust the upper hex nuts (Figure 2, Ref. No. 29) and re-clamp until the desired pressure is obtained. Tighten lower hex nuts securely.
4. If pans or boxes are to be formed, adjust the nose bar (Figure 2, Ref. Nos. 25-28) on the clamping leaf to the length of the bend required and remove the nose pieces on each side of the bend to allow clearance for the work piece. Loosen socket head bolts, (Figure 2, Ref. No. 15), remove or reposition nose bar, then tighten bolts.
5. Raise the clamping leaf by moving clamping handles back. Place work piece on beam and position where bend is required at edge of beam. Clamp leaf onto work piece by pulling clamp handles forward. Do not use pipe extensions on the clamping handles.
6. Slowly pull up bending leaf by the operating handles (Figure 3, Ref. No. 71) until desired angle of bend is obtained, continuing bend slightly to allow for material spring back. Each material has its own rate of spring back, so a trial and error process is necessary to achieve the required bend. Use only operating handles to raise bending leaf. Do not use the counterweight rods to raise bending leaf-damage may occur to leaf hinge.
7. For repeat bends, the collar (Figure 2, Ref. No. 39) is located at the desired position on the guide rod (Figure 2, Ref. No. 37) and secured by the set screw (Figure 2, Ref. No. 44).
8. When bending against seams set back clamping leaf and adjust clamping pressure to allow for the multiple thickness of the seam.

Maintenance

Refer to Figure 2.

LUBRICATION

Use medium weight, non-detergent oil.

MONTHLY:

Oil the bending leaf pivot joint through the oil fittings (Figure 2, Ref. No. 5) located at the right and left pivot points.

MONTHLY:

Oil the clamping handle bearing surfaces through oil fittings (Figure 2, Ref. No. 5) on top of links (Figure 2, Ref. No. 6). Coat all exposed iron surfaces to prevent rusting.

Repair parts list for beam and clamping leaf

Ref. No.	Description	Qty.	Ref. No.	Description	Qty.
1	10-1.5x30mm Hex head bolt	2	25	Nose bar	
2	Spacer	2	29	18-1.5mm Hex nut	4
3	Spring	2	30	10-1.5mm Hex nut	4
4	Left clamping handle	1	31	Pivot block	2
5	Oil fitting	4	32	Adjusting nut	2
6	Link	2	33	Collar	2
7	Clamping leaf	1	34	Top bar	1
8	Pin	2	35	Hand wheel	2
9	Right clamping	1	36	Beam	1
10	10-1.5x40mm Socket head bolt	5	37	Guide rod	1
11	Support block	1	38	Pivot shaft	1
12	Jaw clamp bar		39	Collar	1
15	10-1.5x30mm Socket head bolt		40	Support	2
16	10-1.5x60mm Socket head bolt		41	10-1.5x35mm Socket head bolt	5
17	10mm Lock washer		42	2.5x35mm Cotter pin	5
18-1	Jaw		43	10-1.5x40mm Hex head bolt	4
21	Nose clamp bar	39	44	10-1.5x25mm Socket head bolt	1
24	10mm Flat washer	50	45	4x4.6x30mm Taper pin	2

Figure 2-Repair parts illustration for beam and clamping leaf

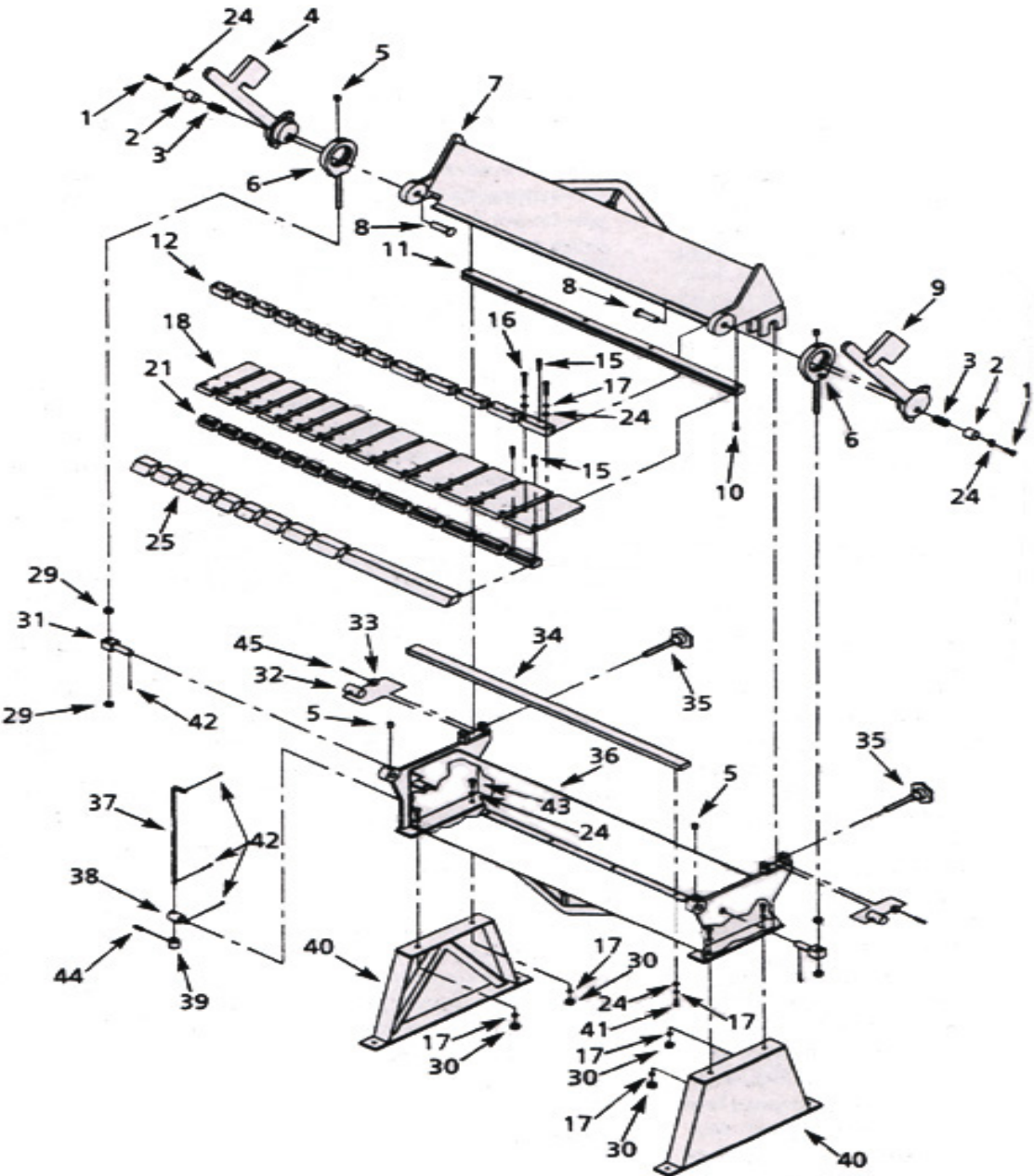

Repair parts list for bending leaf

Ref. No.	Description	Qty.	Ref. No.	Description	Qty.
51	Counterweight	2	61	Operating handle	1
52	Lock collar M30-3.5	4	62	8x30mm Dowel pin	4
53	Counterweight shaft	2	63	12mm Lock washer	6
54	12-1.5x10mm Set screw	4	64	Bending leaf	1
55	Pivot pin	2	65	12mm Flat washer	4
56	12-1.75x20mm Set screw	2	66	12-1.5x40mm Hex head bolt	4
57	12-1.5x40mm Hex head bolt	2	67	10mm Lock washer	8
58	Right hinge	1	68	10-1.5x30mm Socket head bolt	8
59	12-1.75x40mm Hex head bolt	6	69	Angle bar	1
60	12mm Lock washer	4	70	Left hinge	1

Figure 3-Repair parts illustration for beam

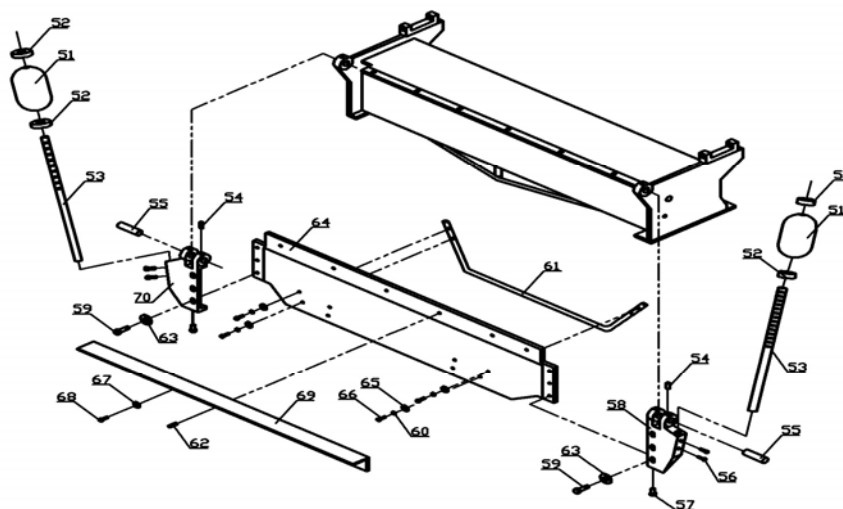

Note: This manual is only for your reference. Owing to the continuous improvement of the machine, changes may be made at any time without obligation on notice.